

## Countermeasures against Heat and Electromagnetic Wave Solution Technology

### Effect

A solution is proposed by utilizing our elemental technology. It has contributed to cost reductions and less engineering.

#### Examples of Heat Simulation

The effect of heat radiation when Kobe Honetsu is applied can be simulated.

#### Heat analysis of DVD Recorder (effect of heat radiation)

Surface Temperature Distribution of Top Cover



Kobe Honetsu

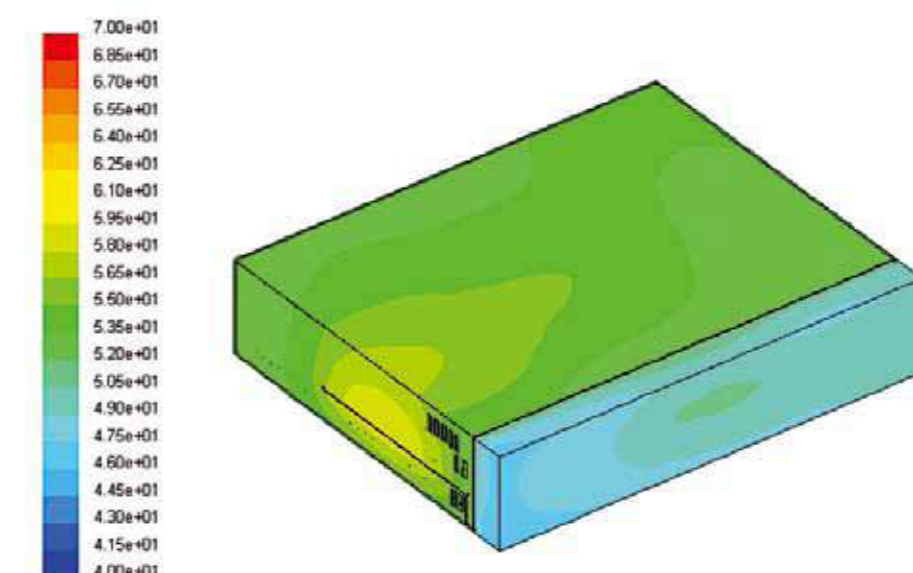

Temperature Distribution in Internal Parts

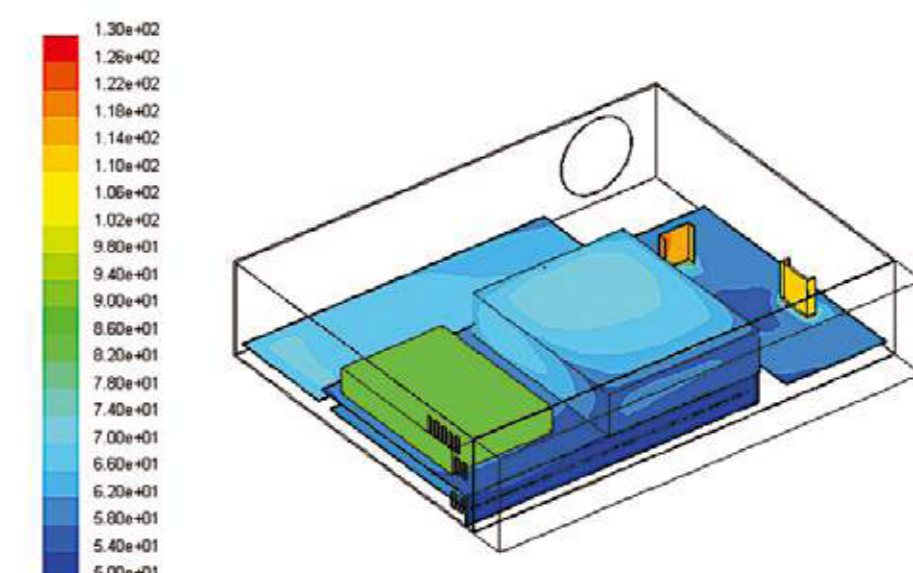
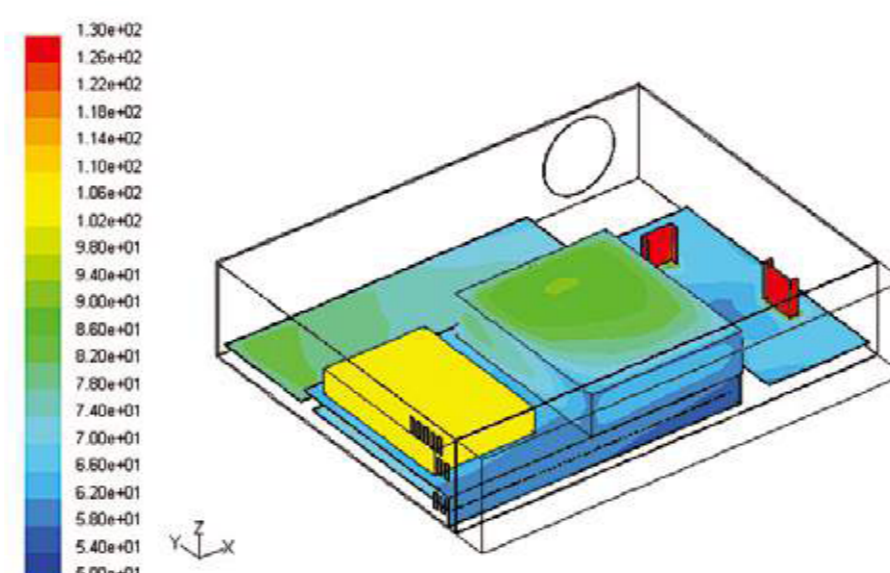

#### Examples of Electromagnetic Wave Simulation

Electromagnetic wave leakage and field intensity can be measured.

#### Electromagnetic Wave Leakage Increased by Resonance

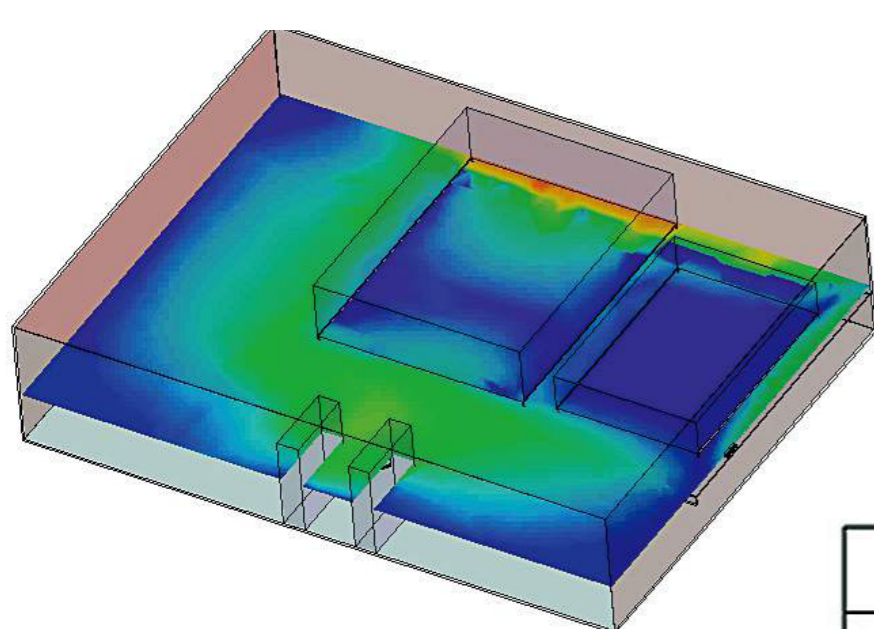

Measured at Side Face of DVD Case (Related to Resonance Frequency Corresponding to Shape of Case)

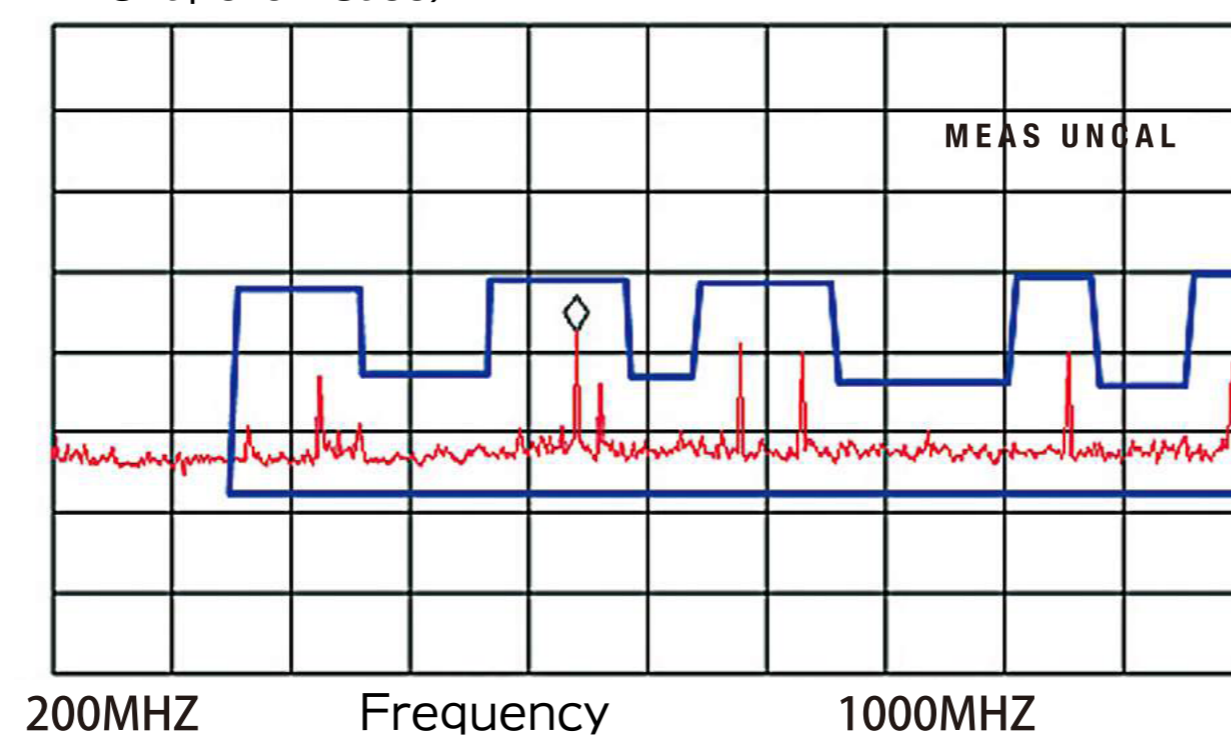

#### Field Intensity to Joint of Steel Sheets

