

"KOBEST®" Design Support System for Beam Material

「Kobelco Optimum Bending property ESTimation system」

Effect Shortening Development Period Weight Reduction, Cost Reduction

Points

Outline of "KOBEST"

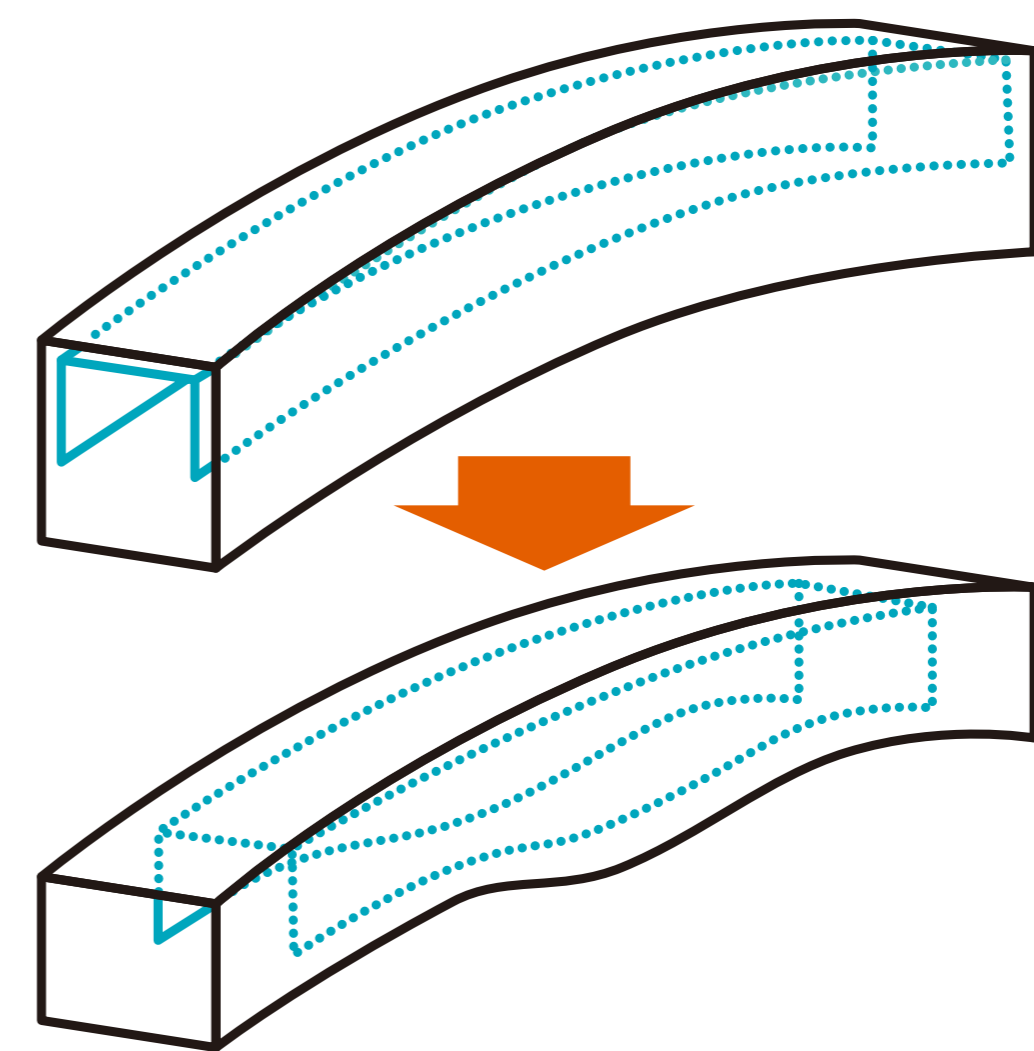
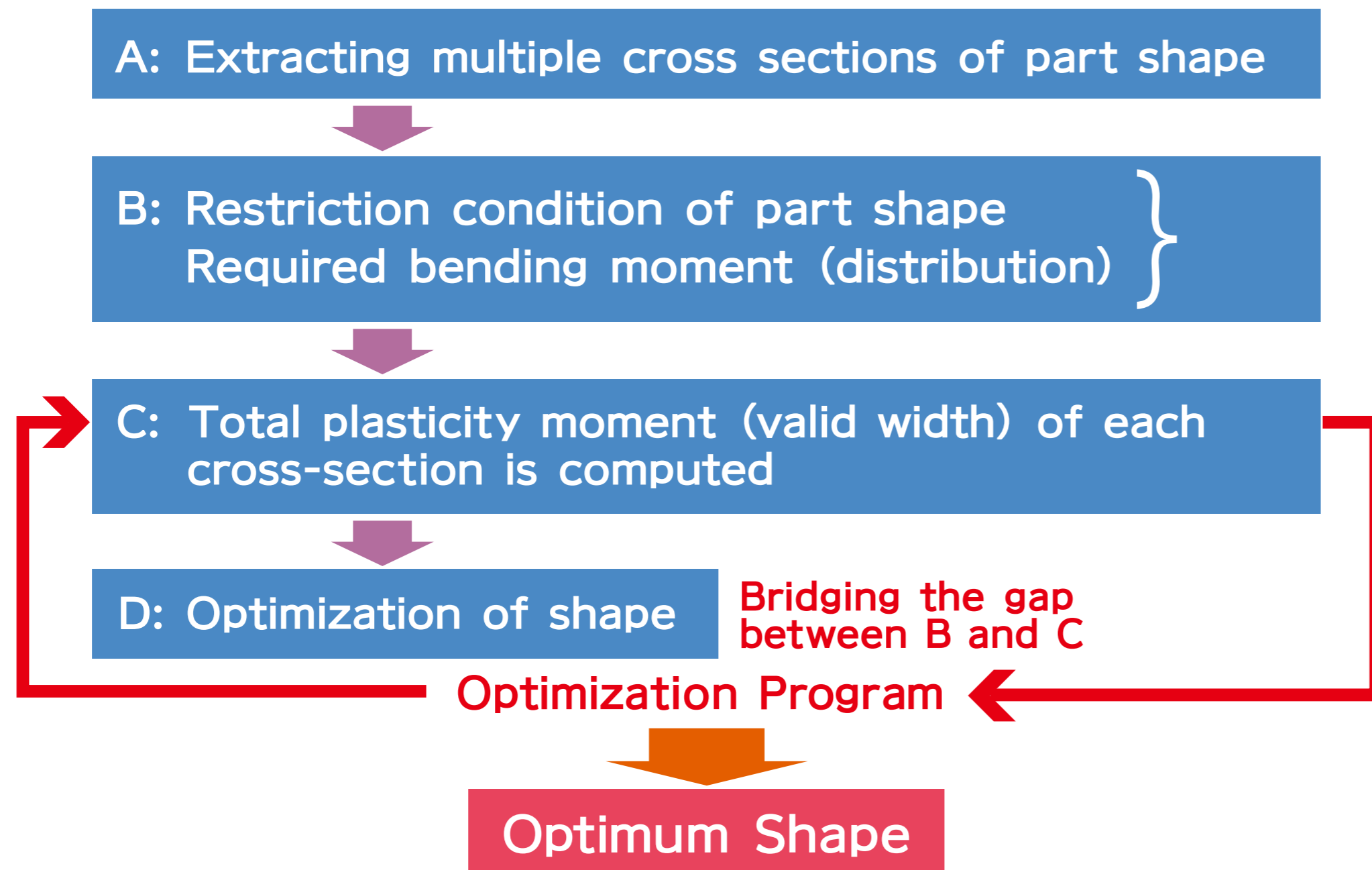

Simplified optimization of the shape is possible

An Example of Discussing Optimization of Automobile Center Pillar

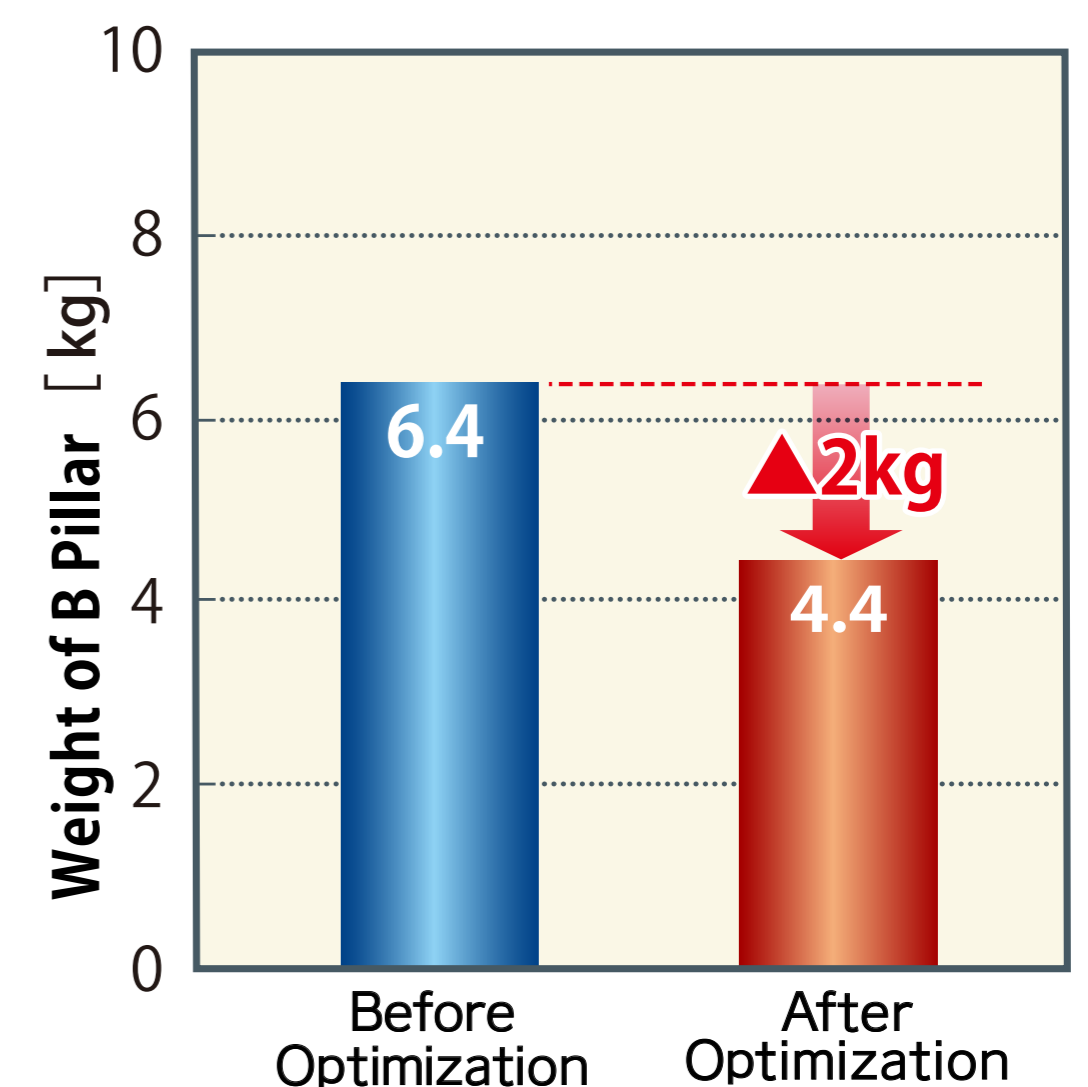
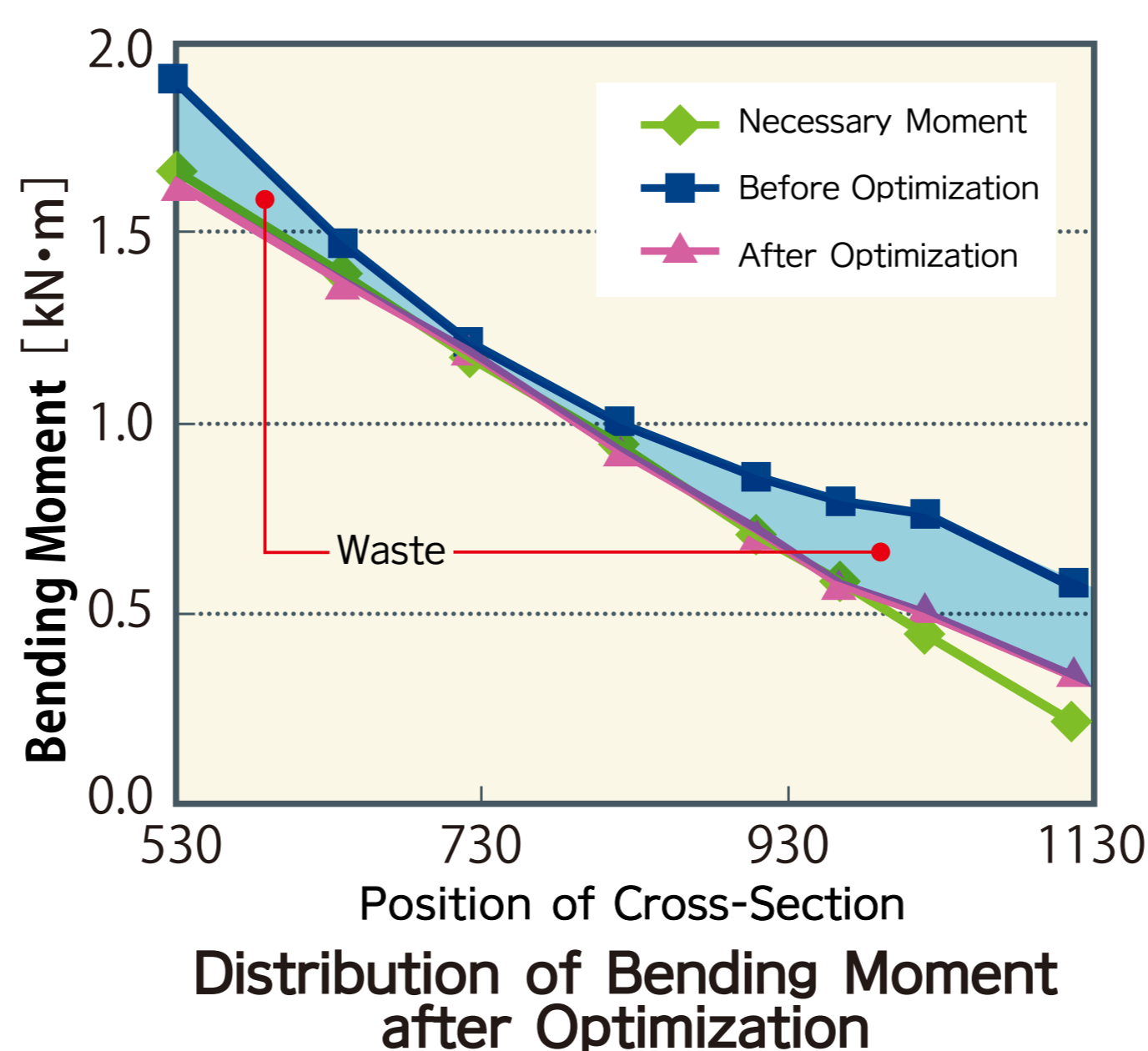
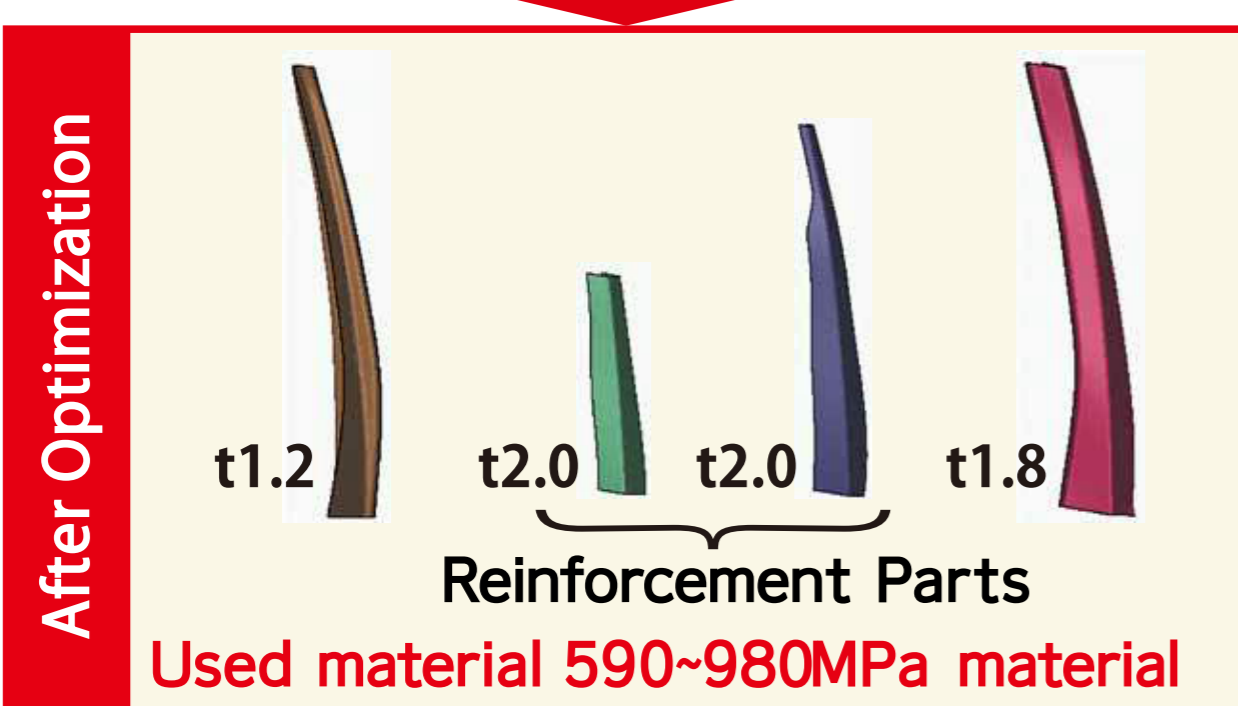
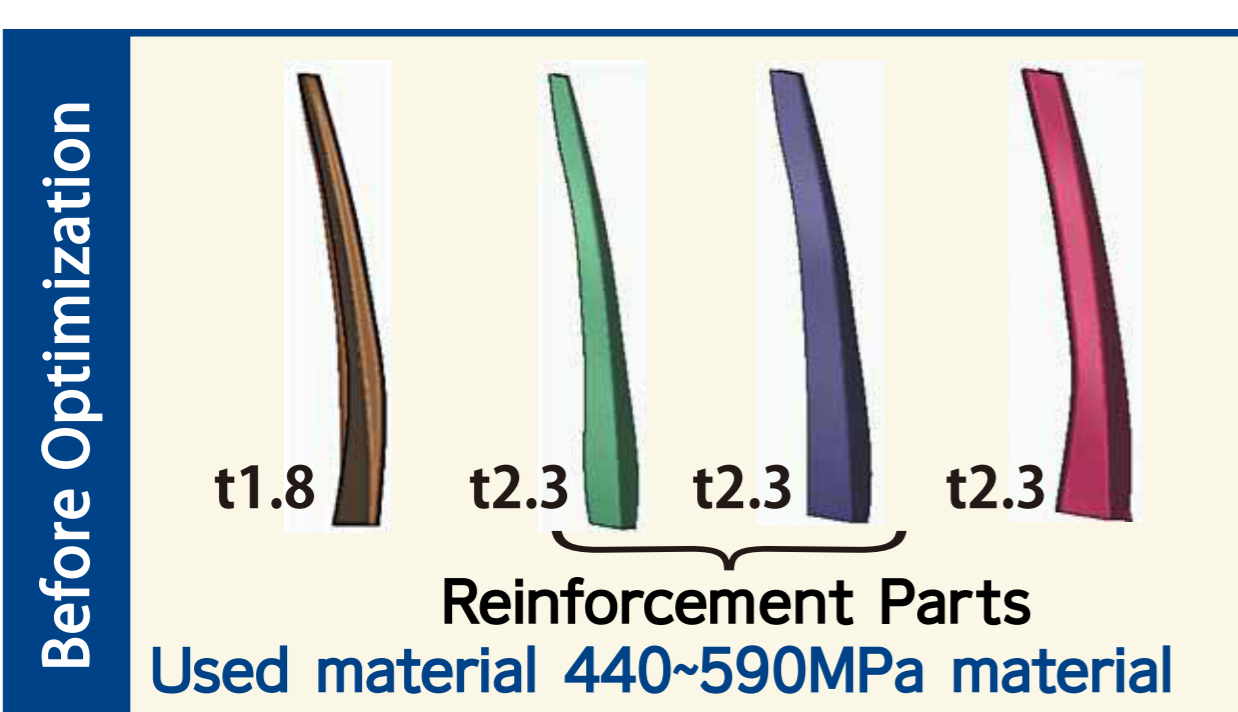

Combinations of the boards and parts shapes that give the necessary moment were automatically obtained

Possible weight reduction by about 2kg (30%)