

**KOBELCO**



# **The ABC's of Arc Welding and Inspection**

**KOBE STEEL, LTD.**

**KOBELCO**



**The ABC's of  
Arc Welding and Inspection**

**KOBE STEEL, LTD.**

Published by **KOBE STEEL, LTD.**

© 2015 by **KOBE STEEL, LTD.**  
5-9-12, Kita-Shinagawa, Shinagawa-Ku, Tokyo  
141-8688 Japan

All rights reserved. No part of this book may be reproduced, in any form or by any means, without permission in writing from the publisher.

*The ABC's of Arc Welding and Inspection* provides information to assist welding personnel study the arc welding technologies applied in steel fabrication.

Reasonable care is taken in the compilation and publication of this textbook to insure authenticity of the contents. No representation or warranty is made as to the accuracy or reliability of this information.

# Introduction

Arc welding is one method for joining metals, and it is indispensable for the construction of steel structures and the fabrication of machinery. The reliability of steel structures and machinery depends on the quality of the welds. The quality of the welds depends on the quality of the steel materials, welding consumables, welding procedures and the integrity of quality control. In order to select correct steel materials, welding consumables, welding procedures, and to conduct appropriate quality control, the personnel in charge of welding should have adequate knowledge of welding technology. *The ABC's of Arc Welding and Inspection* has been published as a textbook for beginners who study the fundamentals of welding technology and inspection. This textbook contains essential information of welding processes, welding power sources, welding consumables, welding design and fabrication, welding metallurgy and weldability, and test and inspection of weldments. This textbook has been edited by employing as many figures and photographs as possible in order to help the beginners fully understand specific technologies of arc welding and related inspection. The information contained in this textbook includes those extracted from the reference books listed below.

## **References**

---

- (1) Kobe Steel, Ltd., "Welding Electrode Handbook," 1964
- (2) Kobe Steel, Ltd., "An Outline of Welding Technology," 1985
- (3) Japan International Cooperation Agency, "An Outline of Welding," 1984
- (4) The Japan Welding Society, "The Fundamentals of Welding Technology," 1986, Sanpo Publications Inc.
- (5) The Complete Book of Welding — Series 6, "Equipment for Fusion Welding," 1978, Sanpo Publications Inc.
- (6) American Welding Society, "Welding Handbook," Eighth Edition, Vol. 1, 1987; Vol. 2, 1991
- (7) American Welding Society, AWS A3.0, "Standard Welding Terms and Definitions," 1989

# Contents

<b>Preface</b> .....	<b>1</b>
<b>1. Welding Processes</b> .....	<b>1</b>
1. 1 Classification of welding processes .....	1
1. 2 Features of arc welding processes .....	2
<b>2. Welding Power Sources</b> .....	<b>7</b>
2. 1 Types and features of arc welding power sources .....	7
2. 2 Characteristics of arc .....	12
<b>3. Welding Consumables</b> .....	<b>17</b>
3. 1 Covered electrodes .....	17
3. 2 Wires for gas-shielded arc welding .....	31
3. 3 Wires for self-shielded arc welding .....	36
3. 4 Wires, strips, and fluxes for submerged arc welding .....	37
<b>4. Welding Design and Fabrication</b> .....	<b>41</b>
4. 1 Welding joints and grooves .....	41
4. 2 Strength of welded joints .....	46
4. 3 Symbols for welding .....	49
4. 4 Welding positions .....	52
4. 5 Welding conditions .....	54
4. 6 Manipulation techniques in welding .....	55
4. 7 Residual stresses and distortion .....	58
4. 8 Preheating .....	60
4. 9 Postweld heat treatment .....	61
4.10 Welding defects and preventive measures .....	61
4.11 Safety in welding .....	66
4.12 Welding costs .....	67
<b>5. Welding Metallurgy and Weldability</b> .....	<b>70</b>
5. 1 Types and features of base metals .....	70
5. 2 Metallurgical features of welds .....	71
<b>6. Test and Inspection of Weldment</b> .....	<b>78</b>
6. 1 Destructive tests .....	79
6. 2 Non-destructive tests .....	83

## Preface

Welding has been used since ancient times, and over the centuries various welding techniques have been devised for making the utensils that are necessary for daily life as well as artistic handicrafts. For more than a thousand years, swords have been made by forging, and sculptures, such as Buddha figures, by soldering and brazing.

The invention of the electric arc early in the 19th century marked the beginning of rapid progress of welding technology in modern times. Nowadays, arc welding has become an indispensable method for joining metals in various fields of industry such as civil construction, shipbuilding, vehicle fabrication, and machinery fabrication. It has expanded its applications by utilizing its advantages and by coping with its drawbacks through unremitting researches and developments.

## 1. Welding Processes

### 1.1 Classification of welding processes

Welding is a method of joining metals in which heat and/or pressure are applied to the area of contact between the two components; a filler metal may be added into the joint depending on the welding process.

Welding methods can roughly be classified into pressure processes, fusion processes, and brazing and soldering by the mechanism of joining metals as shown in Fig. 1.1. In the pressure processes, the joint is made by applying pressure to the area of contact of the two components, which may or may not be heated to a molten state. In fusion processes, two components are joined by heating the area of contact to a molten state, and no pressure is applied. In brazing and soldering, a filler metal having a lower melting point than that of the base metal is melted with a gas torch or in a furnace and is applied to the area of contact. The molten filler metal wets the surfaces of the base metal and is drawn into or held in the joint by the capillary action without fusing the base metals.

These welding processes can be classified further, as shown in Fig. 1.1, by the source of heat used, method of applying pressure, or filler metal's properties. Of these numerous welding processes, the major arc welding processes are outlined below.

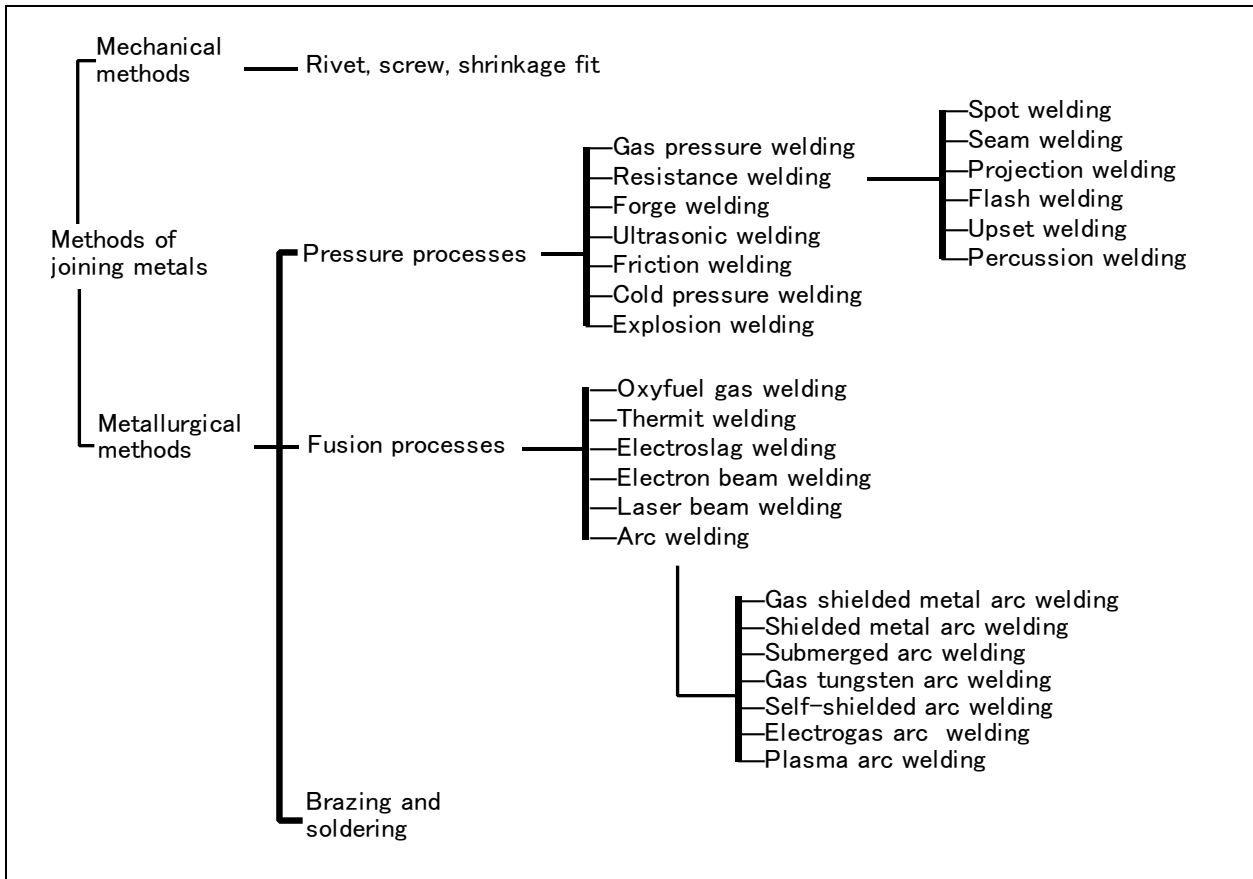

Fig. 1.1 — A classification of metal joining methods

### 1.2 Features of arc welding processes

Among the welding processes listed in Fig. 1, arc welding is the most widely used metal joining process. In arc welding, an electric arc is generated between a base metal and an electrode. The heat of the arc melts the base metal and welding consumable to produce the weld metal for joining structural components.

In one type of arc welding process, the welding consumable serves as the electrode to generate an arc and simultaneously as the filler metal to supply the deposited metal for the weld. This process is called the consumable-electrode welding process, and examples of this process include shielded metal arc welding, gas metal arc welding, submerged arc welding, self-shielded arc welding, and electrogas arc welding. The other approach to arc welding utilizes an electrode which does not melt but only generates an arc to melt both the base metal and the welding consumable. This process is called the non-consumable-electrode welding process. Gas tungsten arc welding and plasma arc welding are typical processes of this type. The general features of the arc welding processes in frequent use are outlined in the following sections.

### 1.2.1 Shielded metal arc welding

The shielded metal arc welding (SMAW) process, which uses flux-coated electrodes (covered electrodes), was invented in 1907. This process features a simple design as shown in Fig. 1.2, easier welding procedures, and low equipment costs. In this process the arc heat generated between the covered electrode and the base metal is used for welding. SMAW is applied for joining almost all types of common metals, utilizing various types of covered electrodes or welding consumables.

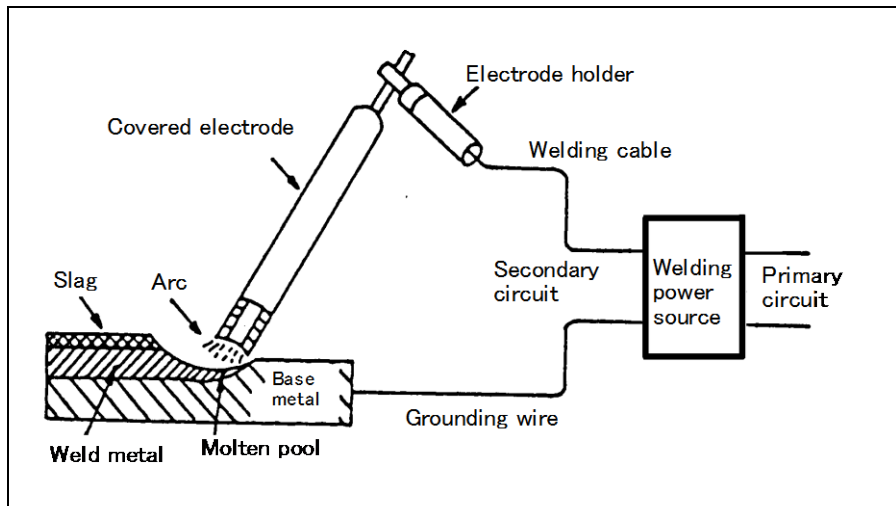

**Fig. 1.2 — Elements of a typical welding circuit for the shielded metal arc welding process**

### 1.2.2 Submerged arc welding

The submerged arc welding (SAW) process was invented in 1935. This process is very efficient because it can use high currents from 500 to 1300 amperes, thereby obtaining deeper weld penetration into the base metal. This process, therefore, is suitable for welding thick-section steel materials. The equipment for and principle of this process are shown in Fig. 1.3. In this process, a fine, granular flux is fed into the welding groove of the base metal, and a solid or flux-cored electrode is fed into the flux while an arc is generated between the electrode and the base metal. Advantages and drawbacks of this process are listed below:

Advantages:

- a) High welding efficiency with high welding currents and high welding speeds
- b) Consistent weld quality due to the mechanized nature of the welding process
- c) Better welding environment because the arc is hidden from sight with the flux applied
- d) Better welding environment because of less emission of welding fumes

Drawbacks:

- a) High welding equipment costs
- b) Unsuitable for short and small-curved welding lines and for vertical and overhead positions
- c) Higher accuracy is required in groove sizes.
- d) The weld quality greatly depends on the chemical composition of base metal and the welding parameters because of deeper weld penetration.



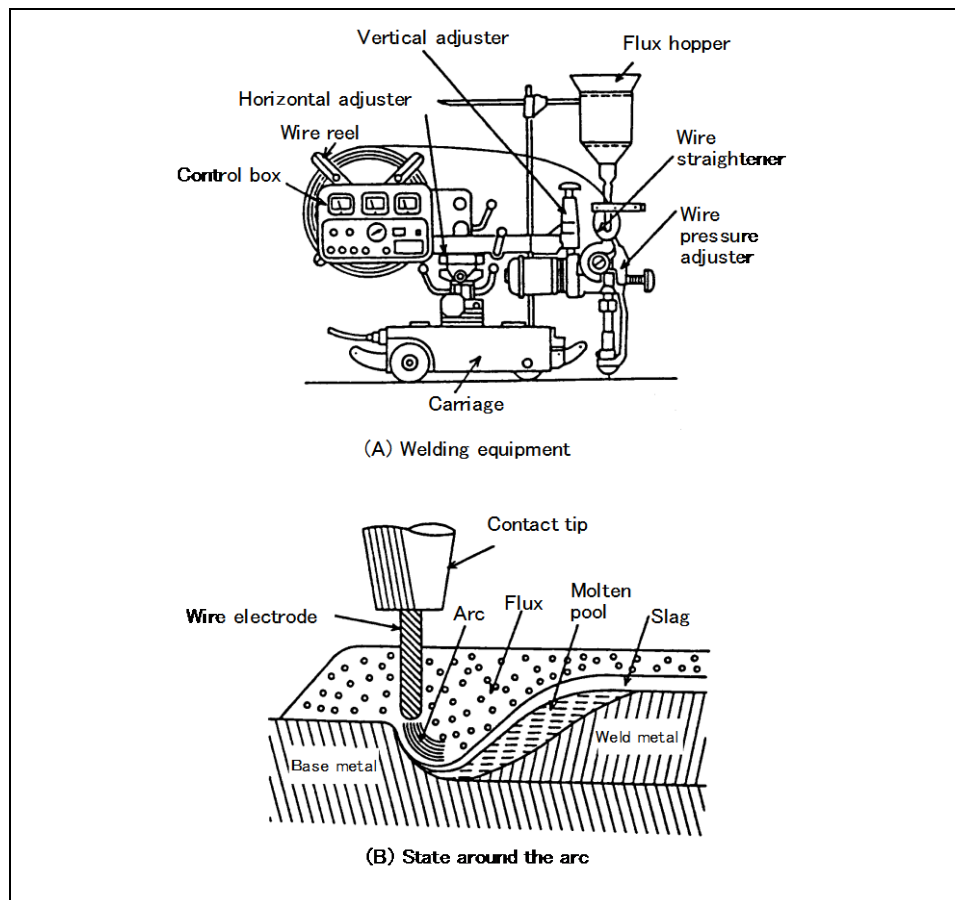

Fig. 1.3 — Equipment for and principle of typical submerged arc welding process

### 1.2.3 Gas shielded metal arc welding

In gas shielded metal arc welding, an arc is generated between a solid or flux-cored (tubular cored) wire electrode and a base metal, while the arc is protected with a shielding gas or gas mixture as shown in Fig. 1.4. Depending on the type of shielding gas, this process is also known as CO<sub>2</sub> welding, metal active gas (MAG) welding, and metal inert gas (MIG) welding. CO<sub>2</sub> welding is most widely used in Japan because of lower prices of CO<sub>2</sub> shielding gas. In contrast, MAG welding with Ar + CO<sub>2</sub> gas mixtures is more popular in Europe and the U.S. Gas shielded metal arc welding with a solid wire is designated as gas metal arc welding (GMAW), and that with a flux-cored wire, as flux cored arc welding (FCAW) in the AWS standard. Gas shielded metal arc welding offers the following advantages with one typical drawback.

Advantages:

- a) The use of higher current density results in deeper penetration, larger deposition rates and faster welding speeds.
- b) Welding costs can be decreased due to higher welding speeds and deposition efficiency.
- c) Suitable for both straight and curved welding joints regardless of its length.
- d) Suitable for both thin sheets and thick plates in all positions

Drawback:

- a) Porosity may occur when the ambient wind disturbs the shielding effect.

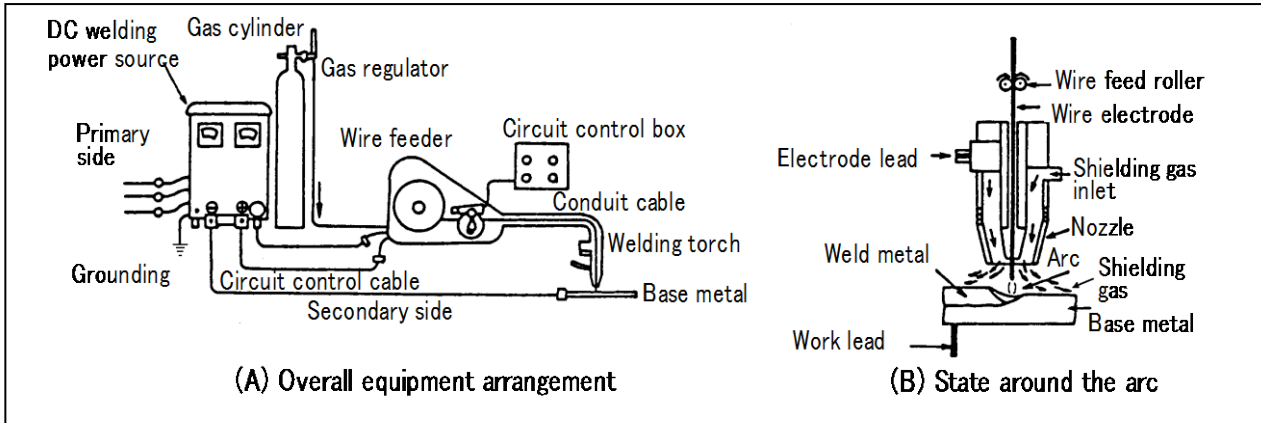
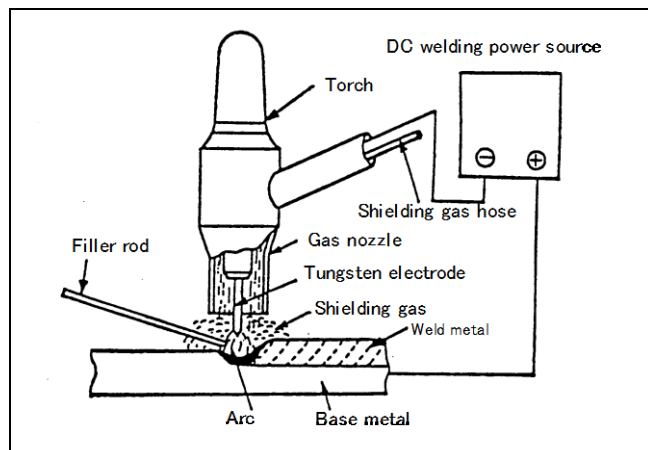

**Fig. 1.4 — Equipment setup for and principle of typical gas shielded metal arc welding process**

When a gas mixture (e.g. 80%Ar + 20%CO<sub>2</sub>) is used for shielding, gas shielded metal arc welding generates low spatter and produces little slag and better bead appearance. This variation is also known as MAG welding. Both solid wires and flux-cored (tubular cored) wires are used as welding consumables in CO<sub>2</sub> and MAG welding. In MIG welding of nickel alloys, copper alloys, and aluminum alloys, an inert gas (e.g. pure Ar) is used for shielding. In MIG welding of stainless steel, a gas mixture of 98%Ar+2%O<sub>2</sub> is used for shielding in order to improve usability and weldability. In MIG welding of low alloy steels, a gas mixture of 95%Ar+5%CO<sub>2</sub> is used for shielding so as to improve usability. Because almost no oxidation reaction occurs, all these variations with the gas mixtures can be called MIG welding. In MIG welding little or no slag is generated, and the amount of spatter is less.

**1.2.4 Gas tungsten arc welding**

Gas tungsten arc welding (GTAW) is also known as tungsten inert gas (TIG) welding. Fig. 1.5 illustrates elements of a typical welding circuit for GTAW. An arc is generated between the tungsten electrode (non-consumable) and the base metal in a shield of inert gas (e.g. pure Ar), and a filler rod or wire is fed into the arc to deposit weld metals. This process is used for welding almost all types of metals. It is particularly suitable for welding sheet metals and tubes.



**Fig. 1.5 — Elements of a typical welding circuit for gas tungsten arc welding**

### 1.2.5 Self-shielded arc welding

In self-shielded (non-gas shielded) arc welding, the gases generated from a flux-cored wire work for the shielding, and no external shielding gas is required. The equipment setup of this process is shown in Fig. 1.6. The AWS standard designates this process as FCAW-S. This process offers the following advantages:

- a) No gas cylinder and hose are required.
- b) Blowholes caused by a high wind rarely occur (up to a wind velocity of 15m/sec.).
- c) AC or DC arc welding power sources for covered electrodes can be used.

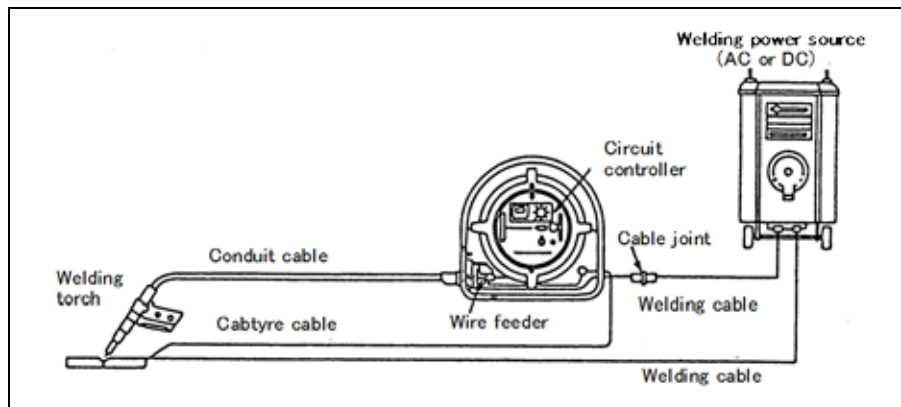

Fig. 1.6 — Elements of a typical welding circuit for self-shielded arc welding

### 1.2.6 Electrode gas arc welding

In electrode gas arc welding (EGW), solid or flux-cored wire is fed continuously, while the arc is shielded generally with CO<sub>2</sub> gas. As shown in Fig. 1.7, weld metal is produced in the area enclosed by water-cooled copper shoes and the edges of the base metal. This process proceeds from the bottom to the top of the work in the vertical position. With this process, high deposition rates can be obtained, and thick-section work (10-100 mm) can be welded with a single pass. Additionally gas-cut square grooves require no machining to obtain sound welds, and welding angular distortion is less, even though the welding position is limited to vertical.

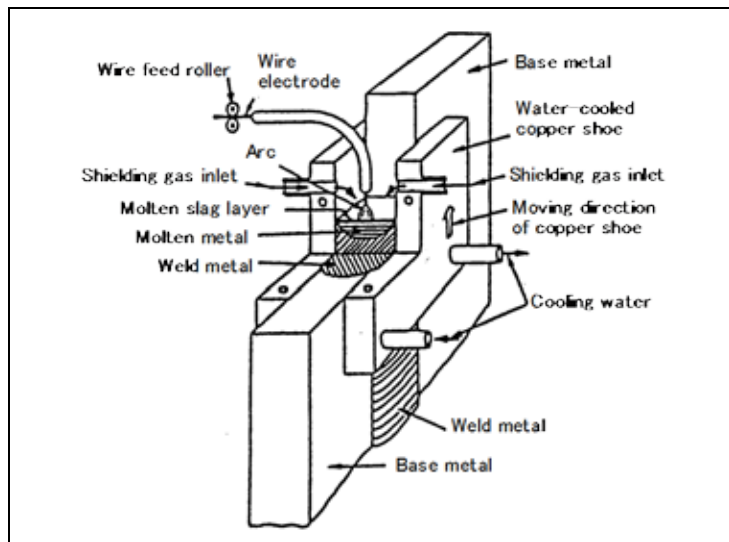

Fig. 1.7 — Elements of a typical electrode gas arc welding process

## 2. Welding Power Sources

All arc-welding processes require a continuous supply of electric current of sufficient amperage and voltage to maintain a stable arc. This current may be either alternating (AC) or direct (DC), and it must be supplied to a welding electrode through a device that enables precise control of the current. This controlling device is called a power source. The current is supplied to the power source from utility power lines, or developed by generators or alternators driven by close-coupled gasoline or diesel engines.

For efficient welding, a power source must be able to control the arc characteristics needed for a specific job. In one job, a forceful, deeply penetrating arc may be required, while, in another job, a soft, less-penetrating arc may be necessary to avoid burn-through. Therefore, the type, capacity and output characteristics of a power source must be thoroughly examined, taking account of the welding procedure to be taken.

### 2.1 Types and features of arc welding power sources

Arc welding power sources are classified according to the type of current (AC or DC) and voltage output (variable-voltage type or constant-voltage type). A further classification designates the method by which energy is supplied to the power source — from a power line directly or through an electric motor (motor-generator type), or from a gasoline or diesel engine (engine-driven type).

Alternating current (AC), obtained directly from the power line, goes through a transformer in the AC power source that allows for the control of the current. Direct current (DC) is produced from the AC line power by either using the line power to run an electric motor that turns a DC generator (motor-generator type) or using the line power through a transformer and then a rectifier (rectifier type). Combination power sources, producing both AC and DC, are basically transformer-rectifier type.

The welding process dictates the type of power source needed. Table 2.1 shows the power source requirements for various processes. Table 2.2 shows the advantages and disadvantages of AC and DC power sources, respectively.

**Table 2.1 — Power source requirements for arc welding processes**

Welding process	Output characteristics	Type of current
Shielded metal arc, Gas tungsten arc, Submerged arc	Variable voltage (1)	AC or DC
Gas shielded metal arc, Electrode gas arc	Constant voltage	DC
Self-shielded arc	Variable voltage	AC
	Constant voltage	DC

Note: (1) A small size wire (2.4 mm or smaller) uses constant- voltage DC in submerged arc welding.

**Table 2.2 — A comparison of DC and AC power sources**

Comparison item	DC power source	AC power source
Arc Stability	Excellent	Less stable
Polarity	Variable	Constant
Arc blow	Yes	Almost none
Open circuit voltage	Lower (50 to 60 V)	Higher (65-95 V)
Possibility of electric shock	Lower	Higher
Machine construction	Complicated	Simple
Maintenance	Not easy	Easy
Noise	Rotary type: noisy Rectifier type: quiet	Quiet
Machine price	Higher	Lower

**2.1.1 AC arc welding power sources**

AC power sources are commonly used for shielded metal arc welding, submerged arc welding, and TIG welding (for aluminum). AC power sources vary according to the method of adjusting welding currents. Welding currents can be adjusted by changing reactance, open circuit voltage and resistance. However, the resistance directly causes the internal loss of electricity, and the open circuit voltage directly affects the stability of the arc. Therefore, welding currents are commonly adjusted by changing the reactance of the circuit.

Fig. 2.1 shows the principle of the movable-core type AC power source that is conventionally used. As shown in Fig. 2.1(A), electric currents are adjusted by inserting or pulling the M3 iron core located between M1 and M2 fixed iron cores. At the location (3) of Fig. 2.1 (B), the leaked magnetic flux can pass most easily, and the welding current becomes smallest. By pulling out the movable core from the fixed iron core the leaked magnetic flux decreases and the welding current increases. Fig. 2.1 (C) shows the output curves of the voltage and current. Overall, this type of AC power source features smaller size, easier welding operation, simpler maintenance, and better durability. These features make this type of power source most popular.

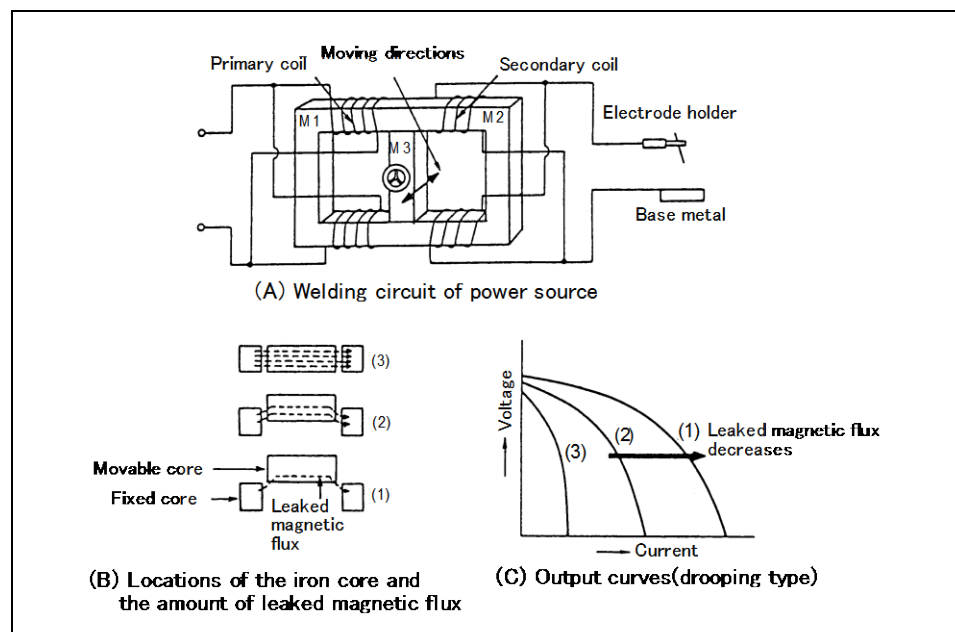
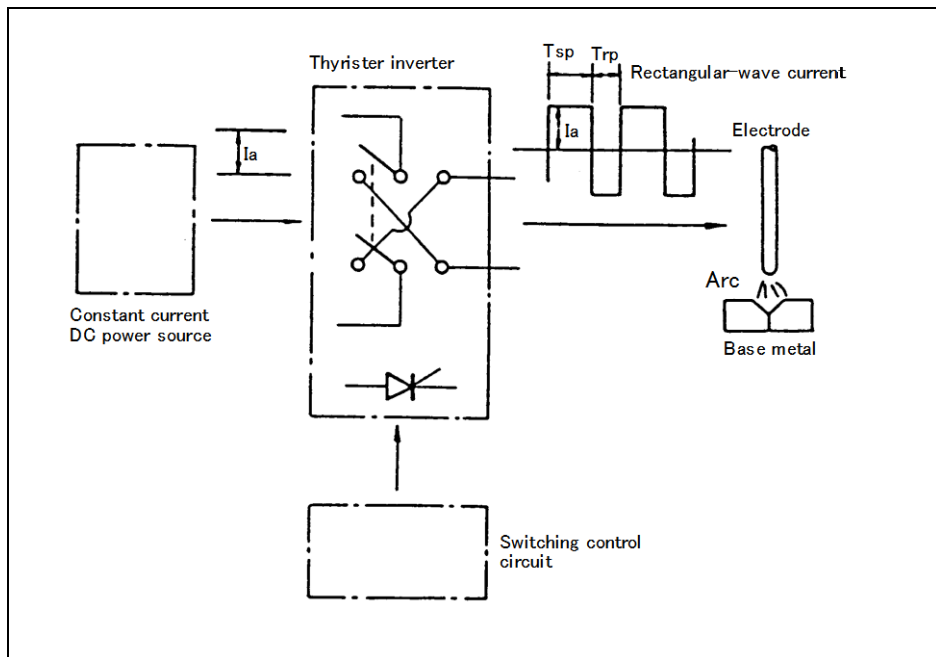

**Fig. 2.1 — The output control in movable-core type AC power sources**

Thyristor-controlled AC-DC multiple power sources are often used due to the following advantages:

- a) It simplifies maintenance of AC power sources with fewer structural parts to be moved for adjusting the current.
- b) It produces a stable arc by controlling the current waveform.
- c) It enables to obtain various output characteristics.

This type has several varieties — the digital-switching type, the reactor-thyristor type, and the inverter type. Fig. 2.2 shows the principle of the inverter type, which was developed for AC-TIG welding. The rectangular-wave current makes the welding arc stable, and the SR ratio ( $T_{sp}$  to  $T_{rp}$ ) can be changed to control the cleaning action, weld penetration, and bead width.



**Fig. 2.2 — The principle of an inverter type AC power source**

### 2.1.2 DC arc welding power sources

DC power sources are commonly used for shielded metal arc welding, submerged arc welding, TIG welding, and gas shielded metal arc welding. DC power sources can be classified by structure into rotary and static types, and further by the method of generating welding current into motor-generator, engine-driven, and rectifier types. Fig. 2.3 (A) shows the principle of a rotary type DC power source. In a direct-current generator, an armature rotates in an electric field. Electric currents are generated in the armature by electromagnetic induction and are taken out for use through a commutator. The armature is rotated by an electric motor in the motor-generator type, and by an internal-combustion engine in the engine-driven type. Fig. 2.3 (B) shows the output characteristic of a DC generator of the third-brush self-exciting type.

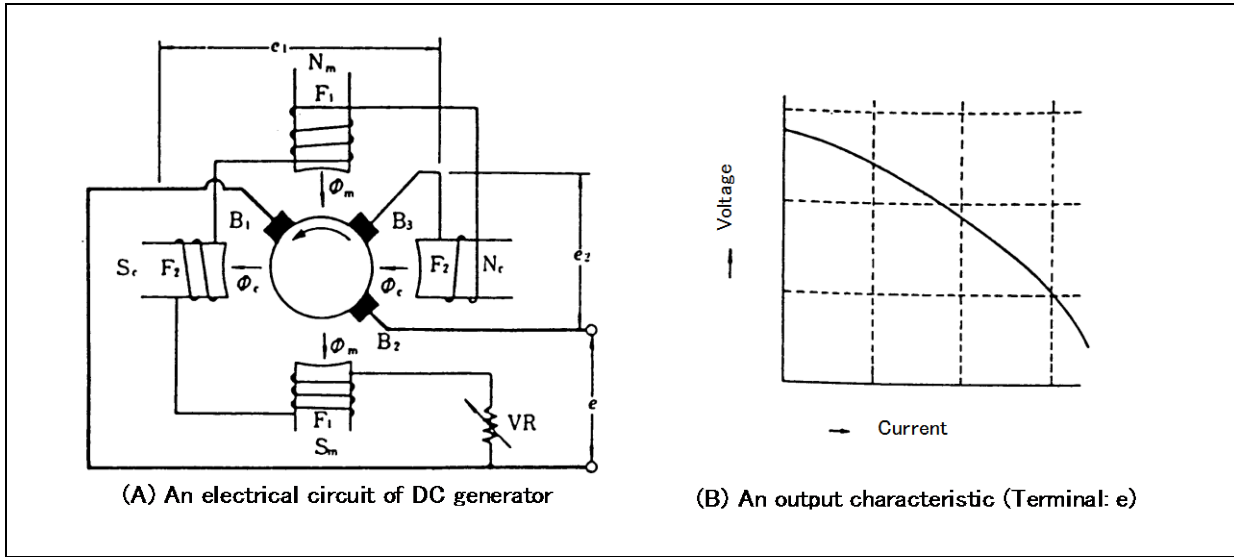

**Fig. 2.3 — An electrical circuit and output characteristic of DC generator power source (Third-brush self-exciting type)**

The constant-voltage, motor-generator power source is a compound generator with a series of electric fields designed to keep the voltage nearly constant within the current capacity of the power source as shown in Fig. 2.4.

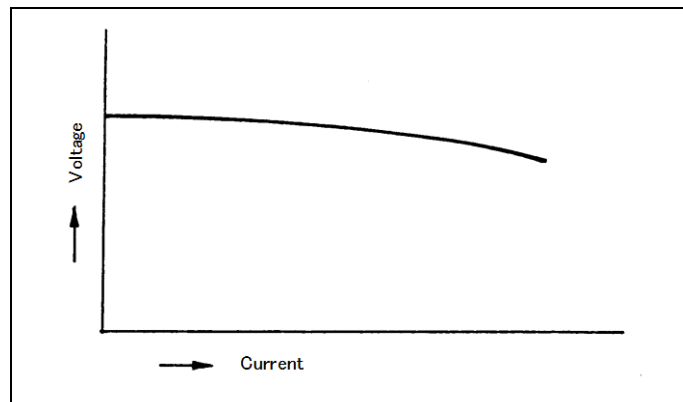

**Fig. 2.4 — A typical output characteristic of constant-voltage DC power source**

The rectifier type power source basically consists of a transformer, rectifier and direct-current reactor as shown in Fig. 2.5.

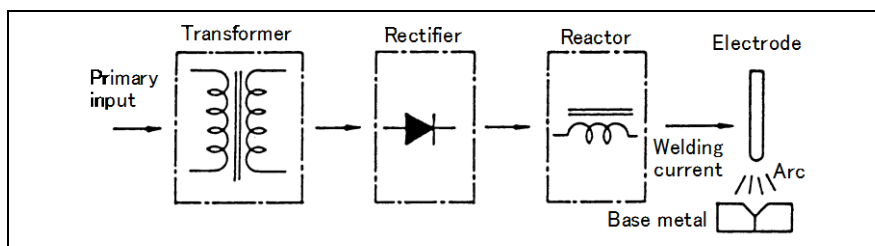

**Fig. 2.5 — Elements of a typical rectifier type DC power source**

In this category of power source, various types are utilized — tapping-transformer type, sliding-transformer type, thyristor-control type, transistor-control type and saturable-reactor type. These types have different mechanisms to control output voltages and currents. The tapping-transformer and sliding-transformer types are only for constant-voltage arc control, but the others have the versatility of both constant-voltage and drooping (constant-current) arc control, and, further, the thyristor-control and transistor-control types have the capability of generating pulsed currents. Fig. 2.6 shows the principle of an inverter-control power source that falls into the transistor-control type, and has several advantages — quick response control, less spatter, and lighter power source.

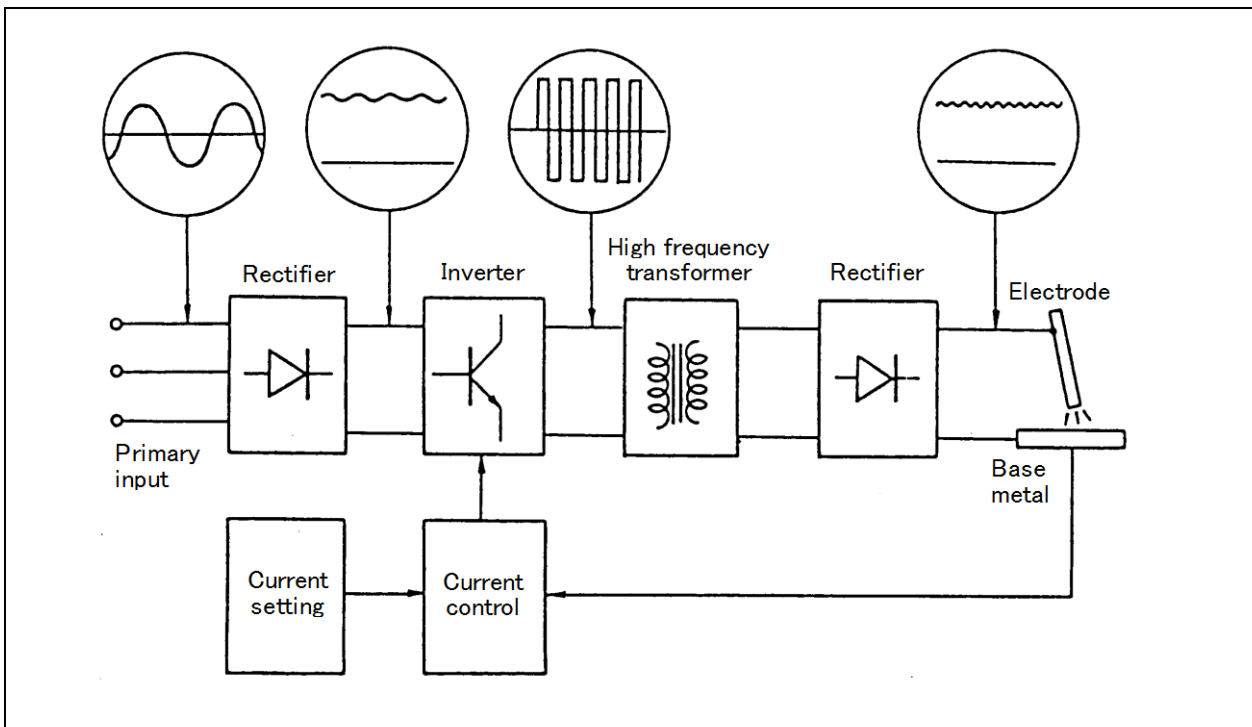

Fig. 2.6 — Elements of a typical inverter control DC power source



## 2.2 Characteristics of arc

### 2.2.1 Voltage and temperature of arc

When two horizontal electrodes that are connected to a DC power source are brought into contact with each other and are then separated, they generate an arc between them. The arc heats the ambient air, and thereby the arc is arched by the buoyancy in the air. The name "arc" originally came from this arched electric discharge. The electrode connected to (+) terminal is called the anode; the electrode connected to (−) terminal is called the cathode, and the electric discharge between them is called the arc column or plasma. The voltage between the electrodes is not uniformly distributed. There are larger voltage drops at the tips of the anode and cathode as shown in Fig. 2.7. The voltage gradually drops in the arc column along its length. These voltage drops are called respectively the anode drop, cathode drop, and arc column voltage drop. The total voltage drop is called the arc voltage.

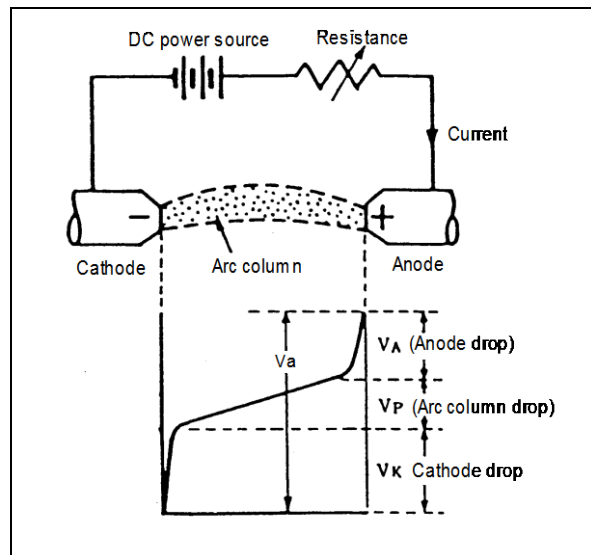

Fig. 2.7 — Arc voltage distribution

When the arc current is given as  $I$ , the electric power  $P_a$  can be given by  $V_a I$ , i.e.  $(V_A + V_P + V_K) I$ , which is supplied into the arc and converted to thermal energy. The electric power of  $V_p I$  is generated by the arc column, whose temperature ranges from 5,000 to 30,000K.

### 2.2.2 Arc control

An electric arc has the unique current-voltage characteristics different from those of the devices such as electric lamps and heaters that use electric resistance loads. In order to generate and maintain a stable arc, the welding power source must have the following characteristics:

- 1) Welding current must remain constant even if the arc length fluctuates.
- 2) The arc voltage must quickly increase so as to prevent the arc from being extinguished when the current decreases.
- 3) Short-circuiting current must be kept low.
- 4) Open-circuit voltage must be appropriate.

In order to fulfill the above requirements, power sources have certain voltage-current output — variable-voltage type (drooping type or constant current type) and constant-voltage type as stated in 2.1.1 and 2.1.2. With the drooping type, the arc is controlled as shown in Fig. 2.8. The point A indicates a balanced condition where the arc is kept stable with an arc length of  $L_1$  during welding. If the arc fluctuates for some reasons, and thus the arc length becomes  $L_2$ , then another balanced condition is accomplished at the point B where the arc voltage becomes higher, but the arc current decreases slightly.

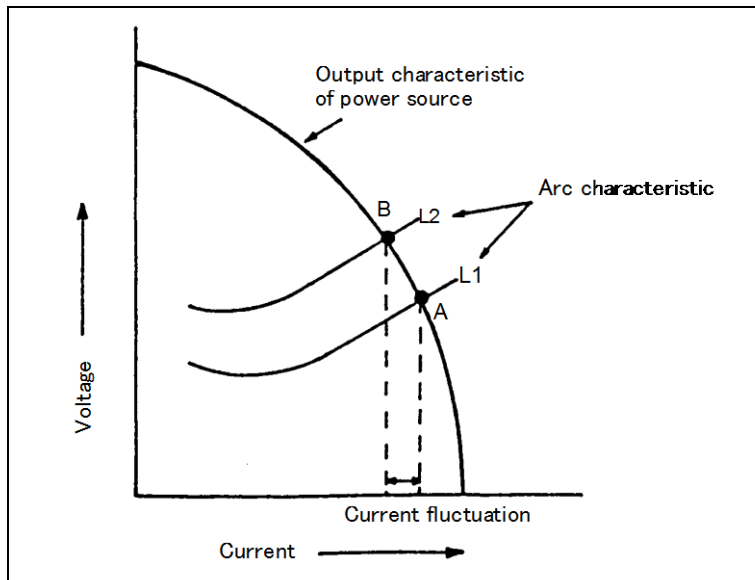

**Fig. 2.8 — How to control an arc stable with a drooping output type power source**

Fig. 2.9 shows the principle of arc controls in submerged arc welding with a drooping type power source. When the arc voltage is increased due to some fluctuation in the arc phenomenon, the feeding rate of the wire electrode is increased, thereby recovering the arc voltage to the previously set value. Conversely, when the arc voltage is decreased because of some fluctuation in the arc phenomenon, the wire-feeding rate is decreased, and thereby the arc voltage is recovered to the previously set value.

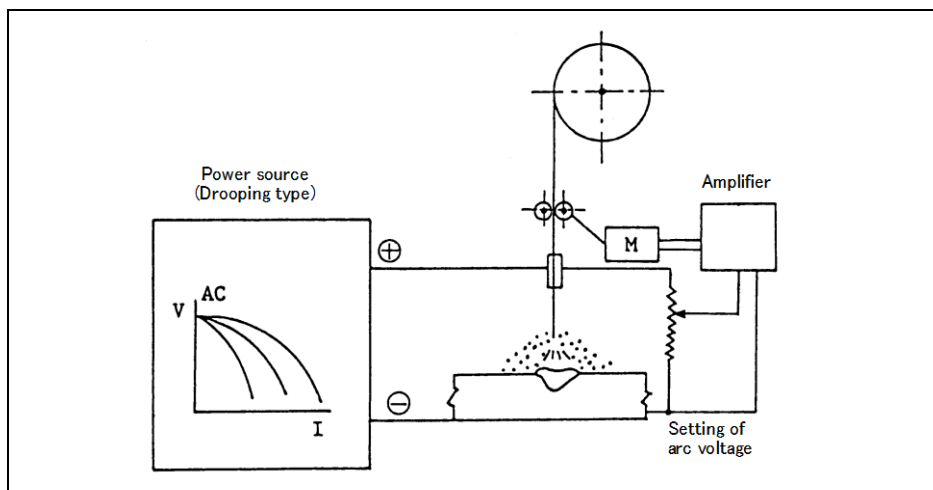

**Fig. 2.9 — How to control the arc in submerged arc welding with an AC power source (drooping type)**

In the case of a constant-voltage type power source, the arc is controlled as shown in Fig 2.10. When the arc length changes, the arc balancing point is transferred in the same way as in the case of the drooping type, but a slight change in the arc voltage results in a large change in the welding current.

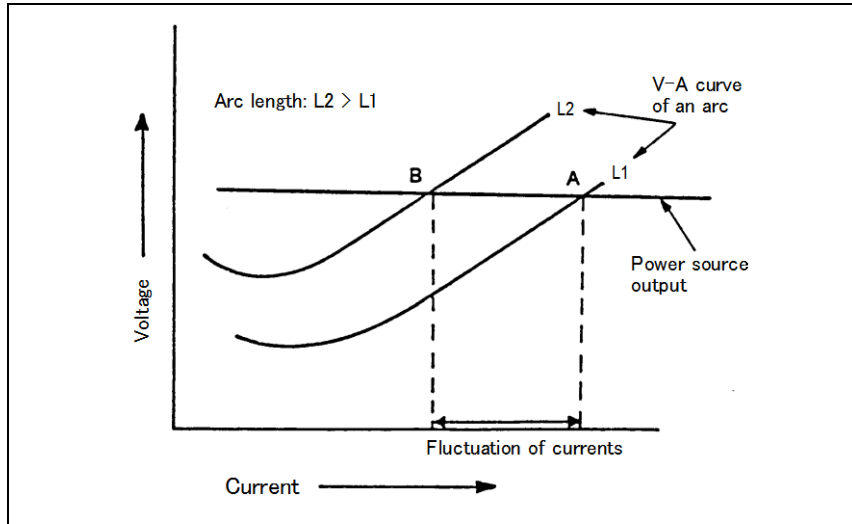

**Fig. 2.10 — How to control the arc stable with a constant-voltage type power source**

Constant-voltage type power sources are used for gas shielded metal welding, electrogas arc welding, submerged arc welding (with small diameter wires), and self-shielded arc welding (DC). Fig. 2.11 shows the principle of arc control in gas shielded metal arc welding by a constant-voltage type power source with a constant rate of wire feeding. When the arc length increases due to some fluctuation in the arc phenomenon, the welding current decreases; consequently, the melting rate of the wire decreases, by which the arc length is recovered. Conversely, when the arc length decreases due to some fluctuation in the arc phenomenon, the welding current increases; thus, the melting rate increases, and thereby the arc length is recovered.

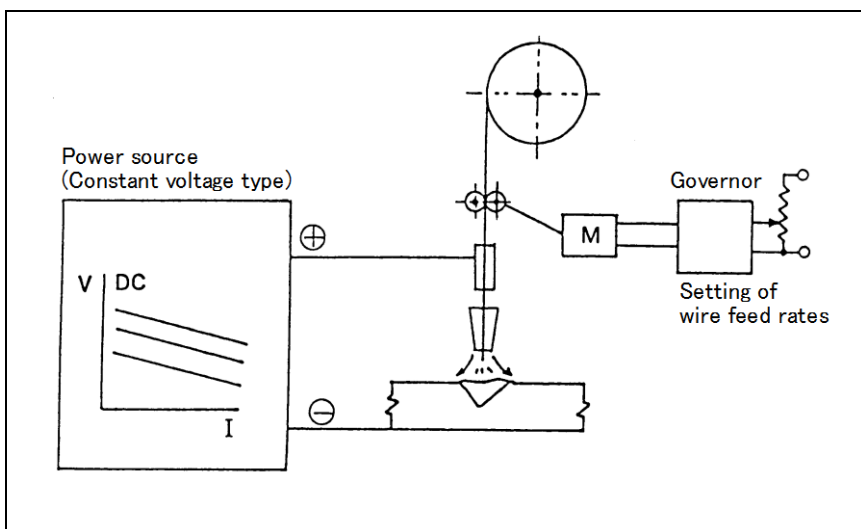

**Fig. 2.11 — How to control the arc in gas shielded metal arc welding with a DC power source (constant-voltage type)**

### 2.2.3 Effects of polarity

In the case of welding with a DC power source, two different methods of lead connection can be used. That is, the electrode can be connected to the positive terminal of a power source (DCEP), or the electrode can be connected to the negative terminal (DCEN), as shown in Fig. 2.12. In shielded metal arc welding, submerged arc welding and gas shielded metal arc welding with DC power sources, the covered electrode and wire mostly use DCEP polarity in general applications. This is because the DCEP polarity results in better arc stability, smoother metal transfer, relatively low spatter, and good weld bead appearance. However, some covered electrodes can use DCEN polarity, and some flux-cored wires for self-shielded arc welding are designed to be used with DCEN polarity.

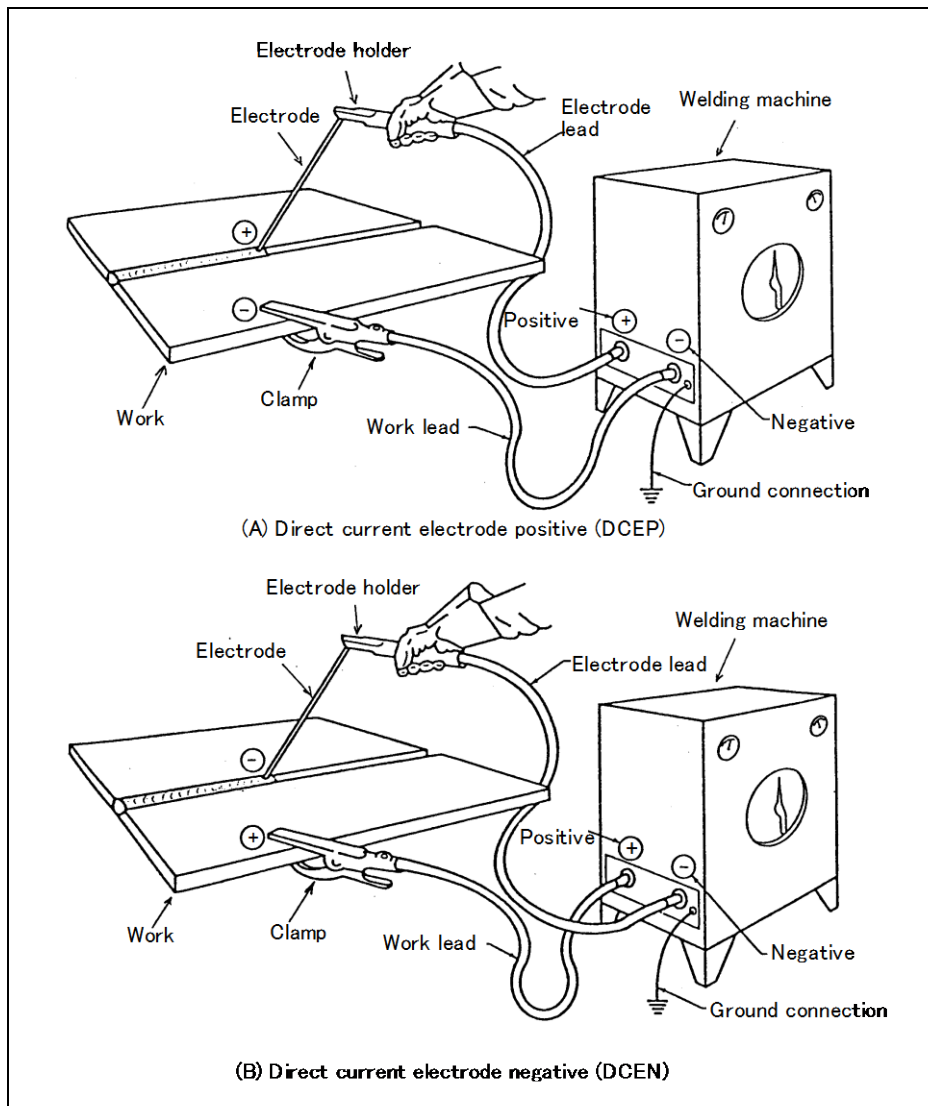

**Fig. 2.12 —Secondary circuit connection in shielded metal arc welding**  
(Source: AWS A3.0:1989)

In TIG welding of general steel materials, DCEN polarity is mostly used. This results in deeper penetration and excellent electrode capacity. On the other hand, TIG welding of aluminum alloys uses either DCEP or AC, because the cleaning action is a must in order to provide complete fusion. Fig. 2.13 compares characteristics of polarities in TIG welding.

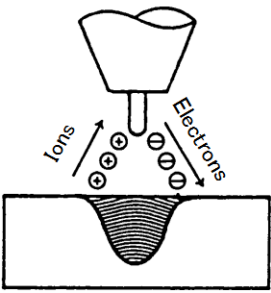
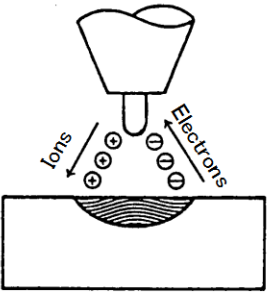
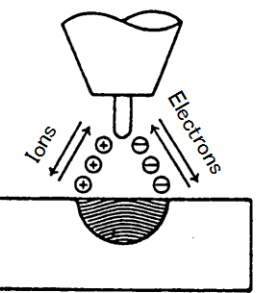
Current type	DC	DC	AC (balanced)
Electrode polarity	Negative	Positive	
Electron and ion flow			
Penetration characteristics			
Oxide cleaning action	No	Yes	Yes — once every half cycle
Heat balance in the arc (approx)	70% at work end 30% at electrode end	30% at work end 70% at electrode end	50% at work end 50% at electrode end
Penetration	Deep and narrow	Shallow and wide	Medium
Electrode capacity	Excellent (e.g., 3.18mm — 400A)	Poor (e.g., 6.35mm — 120A)	Good (e.g., 3.18mm — 225A)

**Fig. 2.13 — Characteristics of current types for gas tungsten arc welding**  
(Source: AWS Welding Handbook)

### 3. Welding Consumables

Most metals can be welded as long as appropriate welding consumables or filler metals and procedures are employed. In order to weld a metal successfully, the welding personnel should have sufficient knowledge of welding consumables (covered electrodes, wires, strips, and fluxes), because the selection and handling of welding consumables greatly affect the quality of welds.

#### 3.1 Covered electrodes

##### 3.1.1 Fundamentals of covered electrodes

A covered electrode consists of the flux material coated on the core wire as shown in Fig. 3.1. A variety of core wires and fluxes are used according to the desired performance of covered electrode.

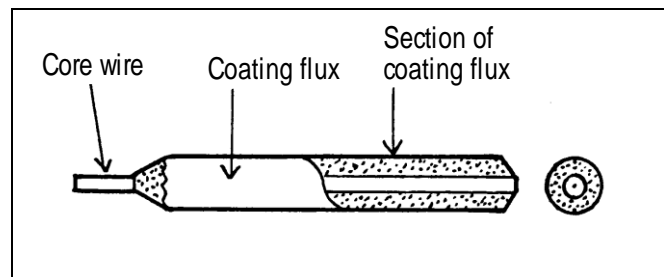

Fig. 3.1 — Structure of covered electrode

##### (1) Core wires

Core wires have two important roles — as an electrode to convey electricity and as a supplier of deposited metal. Different types of covered electrodes may use different types of core wires as shown in Table 3.1. Mild steel and high strength steel covered electrodes use core wires made of dead mild steel that contains about 0.06% carbon. Low alloy steel covered electrodes use core wires made of either dead mild steel or low alloy steel. Stainless steel covered electrodes use stainless steel core wires.

Table 3.1 — Types of core wires for various covered electrodes

Type of covered electrode	Type of core wire
Covered electrodes for mild steel	Dead mild steel
Covered electrodes for high strength steel	Dead mild steel
Covered electrodes for low alloyed steel	Dead mild steel, Low alloy steel
Covered electrodes for stainless steel	Stainless steel
Covered electrodes for hardfacing	Dead mild steel, Low alloy steel, High alloy steel
Covered electrodes for cast iron	Dead mild steel, Cast iron, Nonferrous alloys
Covered electrodes for nonferrous alloys	Nonferrous alloys

The diameter of core wire (the diameter of covered electrode) should be chosen according to applications: thickness of base metal, size of fillet weld, welding position, and permissible welding current. The length of core wire (the length of covered electrode) should also be chosen according to applications: manual welding, spring-contact welding, and gravity welding. Table 3.2 shows standard diameters and lengths of core wires.

**Table 3.2 — Standard sizes and tolerance of core wire of covered electrodes for mild steel (JIS G3523-1980)**

Core wire diameter (mm)	Length of core wire (mm)					
	350	400	-	-	-	-
3.2	350	400	-	-	-	-
4.0	350	400	450	550	-	-
4.5	-	400	450	550	-	-
5.0	-	400	450	550	700	-
5.5	-	-	450	550	700	-
6.0	-	-	450	550	700	900
6.4	-	-	450	550	700	900
7.0	-	-	450	550	700	900
8.0	-	-	450	550	700	900

Notes on the tolerance: Core wire diameter:  $\pm 0.05$  mm  
Length of core wire:  $\pm 3$  mm

A large portion of the core wire becomes a deposited metal in welding. Therefore, the carbon and manganese content of the core wire should be properly adjusted in order to provide the desired quality of the deposited metal. Impurities such as phosphorus, sulfur and copper in the core wires should be lower than in ordinary steels to prevent welding defects. Table 3.3 shows an example of standard chemical composition of the core wire.

**Table 3.3 — Standard chemical composition of core wire for covered electrodes — JIS G3523-1980 SWY-11**

Chemical composition (%)					
C	Mn	Si	P	S	Cu
0.09 max	0.35-0.65	0.03 max	0.020 max	0.023 max	0.20 max

## (2) Coating fluxes

If an electrode is not covered (i.e., only bare wire is used in welding as an electrode), the electrode will stick to the base metal, and an arc will not be easily generated. Even if an arc is generated, it will frequently be interrupted. Consequently, the molten metal will not be deposited continuously on the base metal, and uneven deposited metals will contain blowholes caused by nitrogen and oxygen in the air. In order to prevent these problems, the coating flux is essential for covered electrodes. The main functions of the coating flux are:

- a) To make a concentrated, stable arc
- b) To protect the arc and molten pool with generated gases
- c) To produce slag that covers the weld bead to make the surface smooth and protect it from sudden cooling
- d) To refine weld metals by reducing oxygen and other impurities
- e) To add alloying elements into weld metals
- f) To provide higher deposition efficiency
- g) To provide electrical insulation

About 100 different kinds of powdered raw materials are used as the coating fluxes. These raw materials include oxides, carbonates, silicates, organic matters, fluorides and iron alloys. The coating flux is a mixture of raw materials mixed at a specified combination ratio. The most frequently used powdered raw materials and their functions are listed in Table 3.4.

The main ingredient in a coating flux affects the classification of the covered electrode with the exception of the low-hydrogen type. Table 3 .5 shows examples of the mixing proportions of raw materials and the types of typical covered electrodes for mild steel.

The usability, weldability and welding efficiency of covered electrodes are governed by the coating fluxes. Special covered electrodes for welding high strength steels, heat-resistant low-alloy steels, stainless steels, cast irons, and nonferrous alloys and for hardfacing are designed with more emphasis on the weldability to prevent weld cracks and control the chemical composition and mechanical properties of the weld metal.

**Table 3.4 — Main coating flux ingredients and their functions**

Flux ingredient	Primary function	Secondary function
Cellulose	Gas generation	Deoxidation, Strengthening coatings
Clay	Slag formation	Arc stability
Talc	Slag formation	
Titanium oxide	Arc stability, Slag formation	
Ilmenite	Slag formation	Arc stability
Iron oxide	Slag formation, Oxidation	Arc stability
Lime carbonate	Gas generation	Oxidation, Arc stability, Slag formation,
Ferromanganese	Deoxidation, Alloying	Slag formation
Manganese dioxide	Oxidation	Slag formation
Silica sand	Slag formation	
Potassium silicate	Binding coatings, Arc stability, Slag formation	
Sodium silicate	Binding coatings, Arc stability, Slag formation	



Table 3.5 — Examples of mixing proportions of coating flux ingredients for mild steel covered electrodes (1)

Type of covered electrode (2)	Mixing proportion of coating ingredient									
E4319 (Ilmenite type)	Ilmenite 35	Lime carbonate 6	Medium carbon ferromanganese 15	Manganese dioxide 5	Silica sand 10	Potash feldspar 16	Starch 5	Talc 8		
E4303 (Lime titania type)	Rutile 34	Dolomite 32	Silica sand 10	Feldspar 10	Mica 6	Ferro-manganese 10	Starch 4	—		
E4313 (High titanium oxide type)	Rutile 45	Medium carbon ferromanganese 13	Starch 2	Talc 12	Cellulose 5	Feldspar 20	Lime carbonate 4	—		
E4316 (Low hydrogen type)	Lime carbonate 50	Fluorite 20	Ferrosilicon 10	Medium carbon ferromanganese 2	Iron powder 10	Mica 7	—	—		
E4327 (Iron powder iron oxide type)	Cellulose 3	Talc 10	Medium carbon ferromanganese 16	Potash feldspar 10	Silica sand 20	Iron ore 30	Iron powder 50	—		

Note: (1) An appropriate amount of water glass is added as the flux binder.

(2) The classifications are in accordance with JIS Z 3211:2008 (Covered Electrodes for Mild Steel, High Tensile Strength Steel and Low Temperature Service Steel).

### 3.1.2 Production of covered electrodes

Covered electrodes are produced according to the process shown in Fig. 3.2. If the coating of a covered electrode is not applied concentrically around the core wire, eccentric melting occurs during welding, resulting in poor workability and defective welds. The eccentricity of a covered electrode must be as small as possible, and JIS Z 3200:2005 prescribes the maximum eccentricity of 3% for covered electrodes with 3.2 mm or larger diameters.

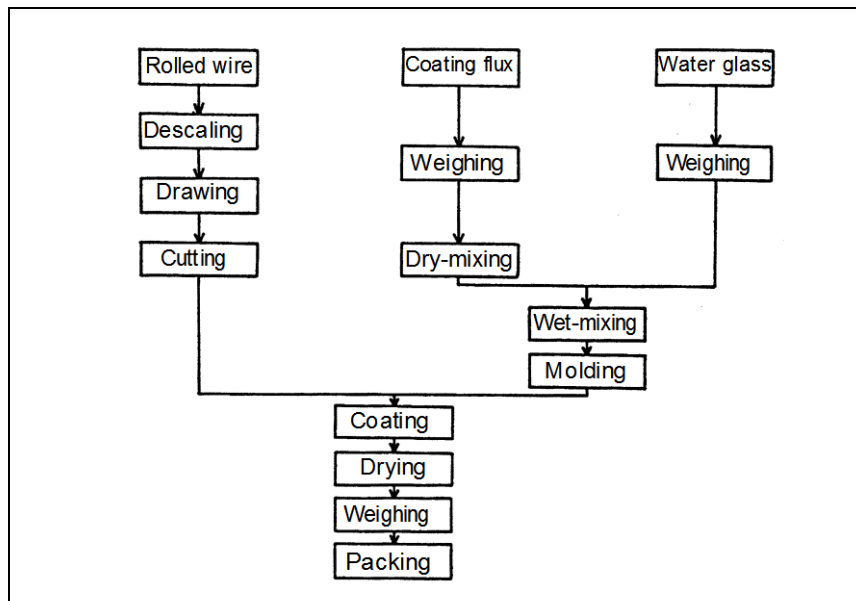

Fig. 3.2 — Typical production process for covered electrodes

### 3.1.3 Types of covered electrodes

Various types of covered electrodes are available, which can be classified according to the kinds of metals to be welded. Fig. 3.3 is a typical classification of covered electrodes.

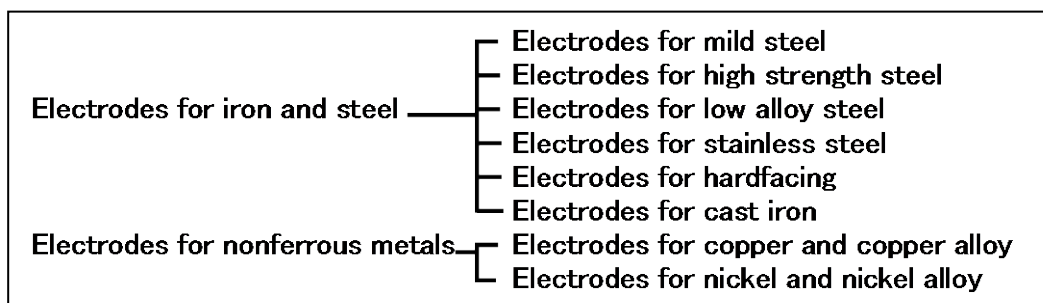

Fig. 3.3 — Classification of covered electrodes according to applicable metals

#### (1) Covered electrodes for mild steel

Mild steel contains a low amount of carbon (0.25% or less) and has a minimum tensile strength of about 400 N/mm<sup>2</sup>. Mild steel is used widely for steel structures due to its excellent cold workability and weldability. Covered electrodes for mild steel are specified by national and international standards.

For example, Table 3.6 shows the American Welding Society (AWS) standard for the covered electrodes for carbon steel, which includes those for mild steel. Table 3.7 compares several major covered electrodes on the welding performance, mechanical properties, chemical composition, and usual applications. The following paragraphs describe the features and intended uses of major covered electrodes classified in the AWS standard, however individual brands have, on any scale, different characteristics.

**Table 3.6 — AWS classification of carbon steel electrodes for SMAW (Excerpted from AWS A5.1:2012)**

AWS classification	Type of flux covering	Applicable welding positions	Type of current and polarity
E6010	High cellulose sodium	F, V, OH, H	DCEP
E6013	High titania potassium	F, V, OH, H	AC, DCEP or DCEN
E6019	Iron oxide, titania potassium	F, V, OH, H	AC, DCEP or DCEN
E6027	High iron oxide, iron powder	H-fillet	AC or DCEN
		F	AC, DCEP or DCEN
E7016	Low hydrogen potassium	F, V, OH, H	AC or DCEP
E7018	Low hydrogen potassium, iron powder	F, V, OH, H	AC or DCEP
E7024	Iron powder, titania	H-fillet, F	AC, DCEP or DCEN
E7028	Low hydrogen potassium, iron powder	H-fillet, F	AC or DCEP
E7048	Low hydrogen potassium, iron powder	F, OH, H, V-down	AC or DCEP

Note: (1) The abbreviations, F, V, V-down, OH, H, and H-fillet, indicate the welding positions as follows:

F: Flat; H:Horizontal; H-fillet: Horizontal fillet; V-down: Vertical downwards; V: Vertical; OH: Overhead

(2) Classification system: EXXXX

- E: designates an electrode.
- The first two digits, 60 and 70, designate the minimum tensile strength (ksi) of the weld metal.
- The third and fourth digits, 10, 13, 19, 27, 16, 18, 24, 28, and 48, designate the welding position in which electrodes are usable, the type of covering, and the kind of welding current for which the electrodes are suitable.

**Table 3.7 — A comparison between major covered electrodes on qualities and applications**

AWS classification		E6010	E6013	E6019	E7024	E7016
Welding performance	Usability	Fair	Excellent	Good	Excellent	Fair
	Weldability	Fair	Fair	Good	Fair	Excellent
	Efficiency	Excellent	Fair	Good	Excellent	Fair
Typical mechanical properties	Yield strength(N/mm <sup>2</sup> )	420	450	410	470	500
	Tensile strength (N/mm <sup>2</sup> )	490	510	460	540	570
	Elongation (%)	27	25	32	27	32
	Impact value (J)	70 (-29°C)	60 (0°C)	110 (0°C)	55 (0°C)	210 (0°C)
Typical chemical composition	C%	0.12	0.08	0.10	0.09	0.08
	Mn%	0.51	0.37	0.43	0.63	0.94
	Si%	0.18	0.30	0.10	0.35	0.60
Usual applications		Vertical-down welding of steel pipes	General use for sheet metals	General use for medium-thick steels	Filletts for medium-thick steels	General uses for medium- and heavy-thick steels

Note: A comparison between Kobe Steel's brands.

**E6010 electrodes:** They are characterized by a deeply penetrating, forceful, spray type arc and readily removable, thin, friable slag. The coverings are high in cellulose, usually exceeding 30% by weight. These electrodes are recommended for all welding positions, particularly with multiple pass applications in the vertical and overhead welding positions. They frequently are selected for joining pipes and generally are capable of welding in the vertical-down position.

**E6013 electrodes:** Their flux covering makes slag removal easier and allows smoother arc transfer. This permits satisfactory operation with lower open-circuit AC voltage. The arc action tends to be quieter and the bead surface smoother with a fine ripple. The coverings are high in rutile. These electrodes are designed specifically for light sheet metal work, providing a low penetration arc. Some brands are recommended for sheet metal applications where their ability to weld satisfactorily in the vertical welding position with downward progression is an advantage. A less-fume-emitting electrode of this type is available, which emits about 30% less fumes than conventional ones.

**E6019 electrodes:** This type of electrode was originally developed around 1940 by using raw materials available in Japan. About one-third of the weight of the coating flux consists of ilmenite ores. These electrodes, with a fluid slag system, offer deeper penetration due to a strong, spray arc and better usability in all positions. In addition, they provide better X-ray soundness, superior mechanical properties, and excellent crack resistibility. These electrodes are suitable for multi-pass welding of up to 25-mm thick steel.

**E6027 electrodes:** The covering contains a large amount of iron powder and is very thick and usually amounts to about 50% of the weight of the electrode, offering a spray-type arc. They will operate at high travel speeds. Arc penetration is medium. Spatter loss is very low. They produce a heavy slag that is honeycombed on the underside. The slag is friable and easily removed. The welds have a flat to slightly concave weld face with a smooth, fine, even ripple, and good wetting along the sides of the joint. This type of electrode is designed, in particular, for fillet welds with a 5- to 10-mm leg length single pass in the flat and horizontal welding positions. These electrodes, therefore, are also known as "fillet welding electrodes." These electrodes are used in the contact welding in which highly efficient semi-automatic welding devices such as the "gravity" and the "auto-contact" are applied. When one welding operator uses three sets of the gravity devices, the welding speed can be 1 m a minute.

**E7016 electrodes:** These electrodes are also known as "low-hydrogen type electrodes" due to the low amounts of diffusible hydrogen contained in the weld metals. Fig. 3.4 shows a comparison of the diffusible hydrogen content of the weld metals of several types of covered electrodes. The low-hydrogen type electrodes are made with inorganic coverings that contain minimal moisture. The main raw material employed in the coating flux of this type of electrode is lime carbonate. The slag, therefore, is chemically basic. The slag is heavy, friable, and easy to remove. The arc is moderately penetrating. The weld face is convex. In addition to their use on mild steel, E7016 electrodes are also used for high strength steel. The low-hydrogen type electrodes are suited for medium to thick base metals due to superior crack resistibility.

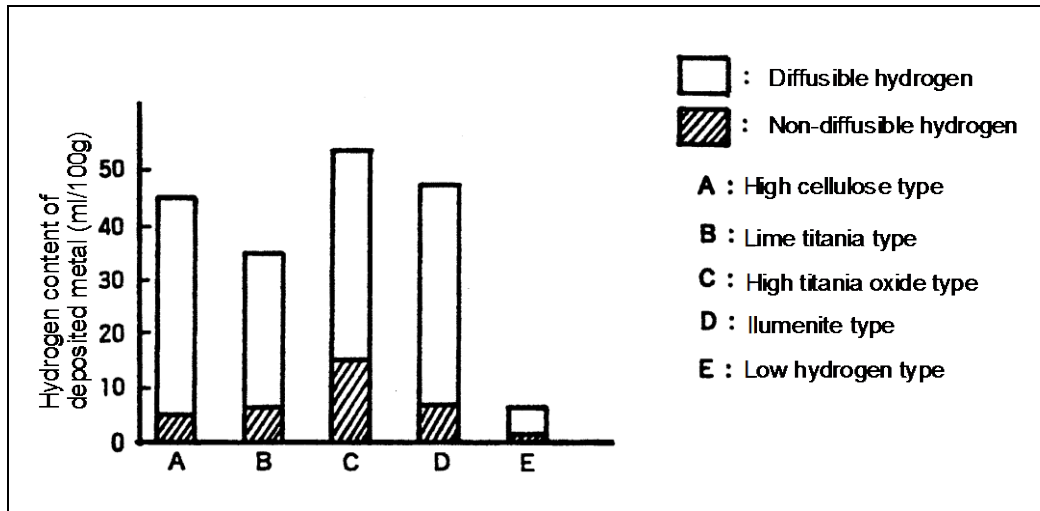

**Fig. 3.4 — Hydrogen content of the deposited metals of several types of covered electrodes (by glycerol displacement method)**

When an inexperienced welder uses a low-hydrogen type electrode, he/she may mistake in starting an arc. If the arc length is kept long when starting an arc, porosity tends to occur in the weld bead. For starting an arc easier without causing porosity, an arc-generating agent is applied on the tip of the electrode, or in addition, the tip of the core wire is shaped as shown in Fig. 3.5. The electrodes with the shaped tip and arc-generating agent offer an easier arc start and a smoother bead-to-bead joint, thereby preventing the occurrence of porosity. As is common with all low-hydrogen type electrodes, the back-stepping technique should be used when starting an arc and the arc length should be maintained to be as short as possible all times. These techniques are very effective to prevent the occurrence of porosity.

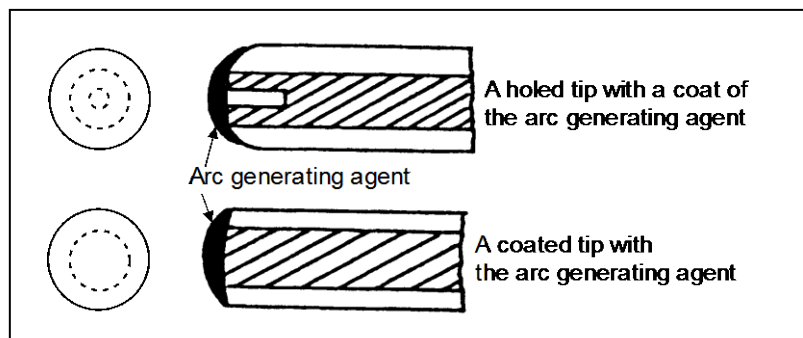

**Fig. 3.5 — Special tips of low-hydrogen type covered electrodes for the sake of easier arc starting, smoother bead-to-bead joining, and the prevention of the porosity occurrence**

For E7016 electrodes, the "uranami" welding electrode or the one-side welding electrode is available, which is exclusively used for melt-through root passes. The "uranami" is a Japanese term which literally means "reverse ripples."

**E7018 electrodes:** The coverings of these electrodes are similar to E7016 coverings, except for the addition of a relatively high percentage of iron powder. The coverings of the E7018 electrodes are slightly thicker than E7016 coverings. Consequently the deposition rates of E7018 electrodes are higher, and they can be used at higher travel speeds. In addition, E7018 electrodes offer better usability with DC currents than E7016 electrodes. A quiet arc, low spatter, and medium arc penetration characterize E7018 electrodes. The fillet welds made in the horizontal and flat welding positions have a slightly convex weld face with a smooth and finely rippled surface; however, an E7018 electrode dedicated to fillet welding offers flat bead shape. E7018 electrodes are suitable for medium to thick base metals due to excellent crack resistance.

**E7024 electrodes:** Their coverings contain large amounts of iron powder in combination with ingredients similar to those used in E6013 electrodes. The coverings of E7024 electrodes are thick and usually amount to about 50% of the weight of the electrode, resulting in higher deposition rates. E7024 electrodes are suited for making fillet welds in the flat or horizontal positions. A quiet arc, very low spatter, low arc penetration, and excellent slag removal characterize E7024 electrodes. The weld face is slightly convex to flat, with a smooth surface and a fine ripple. They can be used with high travel speeds. Some brands can also be used in gravity welding.

**E7028 electrodes:** Electrodes of the E7028 classification are suitable for welding in the flat and horizontal positions. The E7028 electrode coverings are comparatively thicker. They make up approximately 50% of the weight of the electrodes. The iron powder content of E7028 electrodes coverings is higher (approximately 50% of the weight of the coverings). Consequently, E7028 electrodes have a higher deposition rate.

**E7048 electrodes:** Electrodes of the E7048 classification are specifically designed for the exceptionally good vertical welding with downward progression. Slag removal is excellent. The less-fume-emitting type version of this classification emits about 35% less fumes than conventional ones.

## **(2) Covered electrodes for high strength steel**

Covered electrodes for 490- to 780-N/mm<sup>2</sup>-class high strength steels are available. A variety of the covering types are available for high strength steel electrodes; however, low-hydrogen type is mostly used in view of better crack resistance, except for specific applications. High strength steel electrodes are specified in AWS A5.1:2012 (Carbon Steel Electrodes for Shielded Metal Arc Welding) and AWS A5.5:2014 (Low Alloy Steel Electrodes for Shielded Metal Arc Welding).

**(3) Covered electrodes for low-temperature steel**

Low-temperature steel materials have superior notch toughness at temperatures below room temperature. Low-temperature steels include aluminum-killed steel, 3.5%-Ni steel, 9%-Ni steel and austenitic stainless steel. The weldments of low-temperature-service equipment should also have high notch toughness at low temperatures; therefore, low-alloy electrodes are generally used for aluminum-killed and 3.5%-Ni steels. In the welding of 9%-Ni steel, high Ni-alloy electrodes are used. In the welding of austenitic stainless steel, the matching electrode whose chemical and mechanical properties are similar to those of the base metal is used. Low-alloy electrodes are specified in AWS A5.5:2014 (Low Alloy Steel Electrodes for Shielded Metal Arc Welding). Stainless steel electrodes are specified in AWS A5.4:2012 (Stainless Steel Electrodes for Shielded Metal Arc Welding). High Ni-alloy electrodes for 9%-Ni steel are specified in JIS Z 3225:1999 (Covered Electrodes for 9%-Ni Steel), which are also specified in AWS A5.11:2010 (Nickel and Nickel-Alloy Welding Electrodes for Shielded Metal Arc Welding).

**(4) Covered electrodes for stainless steel**

Stainless steel materials are suitable for corrosion resistant, heat resistant, and low-temperature applications. For welding stainless steels, covered electrodes that match the base metal are used. The coatings of these electrodes are of lime titania type and lime type. The lime titania type is more common. The covered electrodes for austenitic stainless steel are designed so as to contain a certain percentage of ferrite in the austenite matrix of the weld metal. This is to prevent hot cracks in the weld metals. Among the electrodes for ferritic stainless steel and martensitic stainless steel, Nb-bearing electrodes, which produce ferritic weld metals with fine crystal grains, are used in order to improve weldability and mechanical properties. Stainless steel electrodes are specified in AWS A5.4:2012 (Stainless Steel Electrodes for Shielded Metal Arc Welding).

**(5) Covered electrodes for heat-resistant low-alloy steel**

For such applications as boilers, chemical equipment, and petroleum refining equipment, heat-resistant low-alloy steels are used. These steels include molybdenum steel and chromium-molybdenum steel. For welding these steels, covered electrodes that match the base metal are used. Most of these electrodes are specified in AWS A5.5:2014 (Low Alloy Steel Electrodes for Shielded Metal Arc Welding) and some high-Cr electrodes are specified in AWS A5.4:2012 (Stainless Steel Electrodes for Shielded Metal Arc Welding).

**(6) Covered electrodes for cast iron**

Cast iron contains a large amount of carbon (3 to 4%C). Consequently, its weldability is poor in comparison with that of steels. Welding of cast iron, however, can be successful, if appropriate welding procedures are taken. Among a variety of cast irons, ductile cast iron has the best weldability. Electrodes for cast iron are specified in AWS A5.15:90(R2006) (Welding Electrodes and Rods for Cast Iron). AWS ENi-CI and ENiFe-CI electrodes are widely used because of the better weldability and the machinability of the welds with lower hardness. ENi-CI electrodes use pure Ni core wires, and ENiFe-CI electrodes use Fe-Ni alloy core wires. Their coatings are made of mainly graphite flux. AWS ESt electrodes are made of dead mild steel core wire coated with low-hydrogen type flux.

**(7) Covered electrodes for other metals**

In addition to the covered electrodes described above, other types of electrodes for specific applications are available. There are hardfacing electrodes for extending the life of machinery components, nickel and nickel alloy electrodes for providing superior heat and corrosion resistance, and copper and copper alloy electrodes for providing corrosion resistance.

**3.1.4 Handling and storage of covered electrodes**

Because covered electrodes tend to absorb moisture, they should be properly stored and redried before use according to the supplier requirements in order to assure sound welds. The following sections discuss the factors that govern moisture absorption and how to store and redry covered electrodes.

**(1) Moisture absorption**

Different types of covered electrodes have different compositions of the coating fluxes. Their moisture absorption rates, therefore, differ in the same atmospheric condition, as shown in Fig. 3.6. When covered electrodes are stored in a high-temperature high-humidity area, the moisture absorption rates become higher as shown in Fig. 3.7.

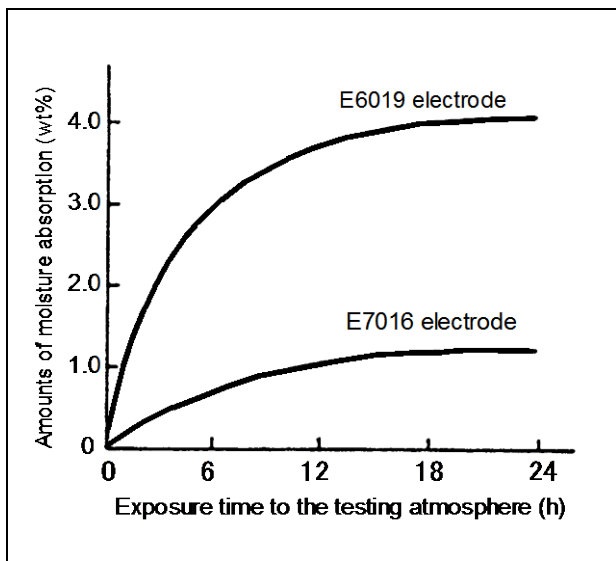

**Fig. 3.6 — Moisture absorption versus the type of electrode in the constant testing atmosphere (30°C x 80%RH)**

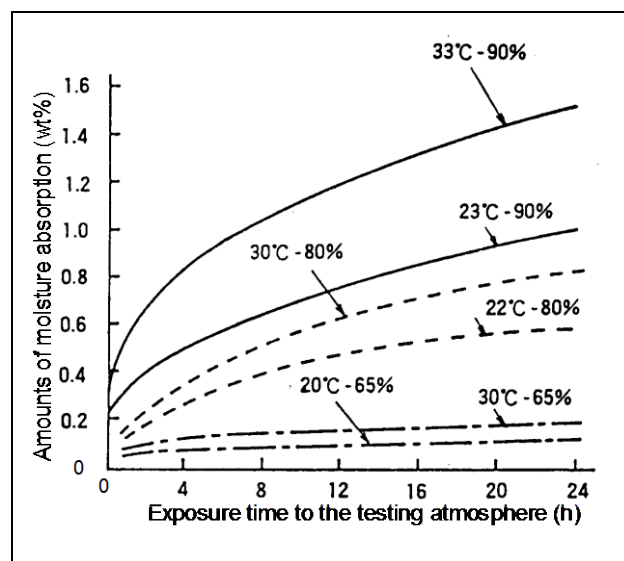

**Fig. 3.7 — Moisture absorption rates of an E7016 electrode in the various testing atmospheres**

The amount of moisture absorption of covered electrodes varies depending upon how the electrodes are placed in the storage as shown in Fig. 3.8. This test result suggests that covered electrodes should be stored in a slender container so as to minimize moisture absorption when welders handle electrodes at the welding sites.



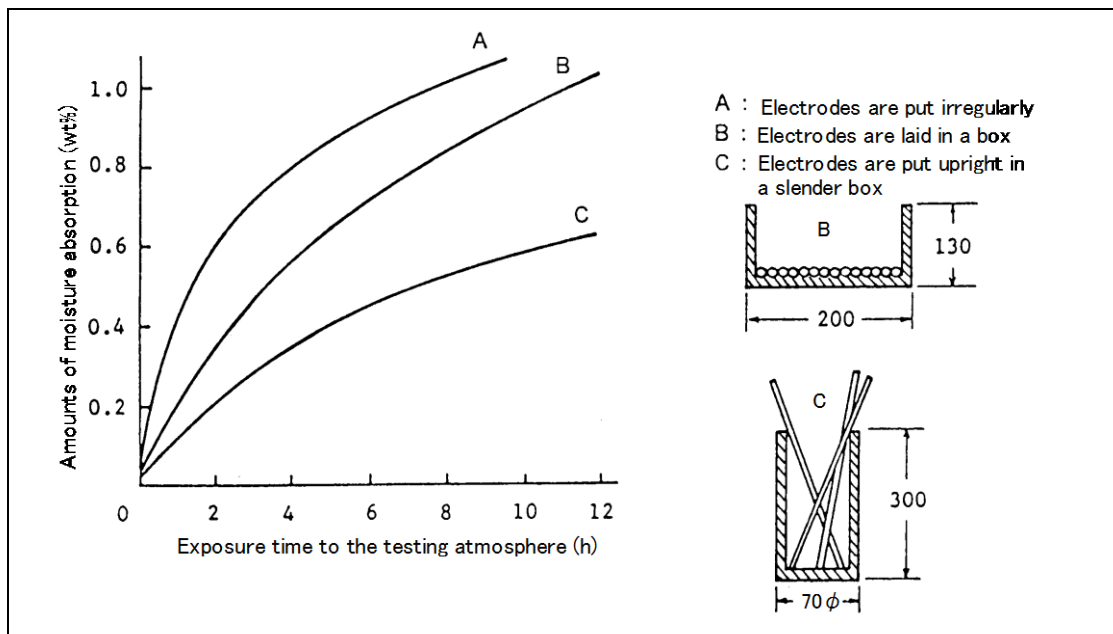

**Fig. 3.8 — A comparison between three different storage ways for E7016 electrodes on the moisture absorption rates in the constant atmospheric condition (25°C x 90%RH)**

When covered electrodes absorb moisture, usability and weldability of the electrodes may decline; typical signs of degraded usability and weldability are:

- a) A stronger and unstable arc
- b) Increased amounts of spatter
- c) Deeper penetration and increased undercut
- d) Irregular slag covering and rough bead surface
- e) Poor slag removal
- f) Cracking of welds
- g) Blowholes in welds

If electrodes that contain a large amount of moisture are used, they may cause various welding defects. Therefore, it is important to know the permissible limits of moisture absorption for obtaining the optimum performance of an electrode. Such limits are given below for a general guidance (Refer to the specification of the electrodes manufacture for a specific electrode).

- a) 0.5%: the permissible moisture absorption for low-hydrogen type electrodes to restrict the amount of hydrogen in the deposited metal for maintaining good crack resistance.
- b) 2 to 3%: the permissible moisture absorption for non-low-hydrogen type electrodes to maintain good usability and X-ray soundness.

## **(2) Redrying**

Electrodes are stored sometimes for a long period from the time of production to the time of use at sites. During this period, they may be exposed to a humid atmosphere and may absorb a considerable amount of moisture. The extent of the degradation of performance caused by absorbed moisture depends upon the type of electrode. In the case of low-hydrogen type electrodes, even a small amount of absorbed moisture should be noted, because this type of electrode is commonly used with heavy thick steel materials that tend to experience hydrogen-assisted cracking. Therefore, redrying or conditioning the electrodes is necessary prior to use in order to restore their low hydrogen character. In the case of other types of electrodes, with exception of a certain high-cellulose type, redrying prior to use is needed in order to restore their usability and x-ray soundness.

For redrying, it is necessary to determine the temperature, time and number of redrying cycles carefully. Too high or too low redrying temperature may cause problems with the electrode. Too high temperature may cause decomposition of the gas generating agents and deoxidizers contained in the coating flux, which leads to the generation of blowholes in the weld metal as well as to a decrease in the strength and toughness of the weld metal. If the redrying temperature is too low, the absorbed moisture cannot be removed sufficiently.

Table 3.8 shows the optimum redrying conditions, but it should be noted that they may differ depending on the brand of electrode. Normally, redrying may be repeated a maximum of three times for low-hydrogen electrodes and a maximum of five times for non-low-hydrogen electrodes, depending on the welding work schedule. Electrodes will not change their appearance even if they are redried more times, but the binding agents in the coating flux may deteriorate and the coating may partially break off during welding. It is desirable to predetermine the amount of electrodes to be used on a particular day and to redry only that amount. Leftover electrodes may be used on the following day after redrying them again.

## **(3) Storage**

When electrodes have absorbed moisture, their inherent characteristics may be damaged. In that case, redrying electrodes can restore their original quality. However, it is more important to store them in a proper area and to use the older electrodes first. Precautions to be paid when storing electrodes are listed below:

- a) Store electrodes in a well-ventilated area and keep electrodes away from the floor and the wall of the storehouse.
- b) Mark clearly the date of receiving electrodes and stack them in such a manner that older electrodes can be taken out first.
- c) Clearly indicate the types, brands, and sizes of electrodes.
- d) Keep electrodes stacked at an appropriate height.

Table 3.8 — Optimum redrying conditions for various types of covered electrodes

Applications	Type of coating	Approx. moisture requiring redry (%)	Redrying temperature (°C)	Redrying time (min)	Applications	Type of coating	Approx. moisture requiring redry (%)	Redrying Temperature (°C)	Redrying Time (min)
Mild steel	Ilmenite	3	70 - 100	30 - 60	Stainless steel	Lime titania (1)	1	150 - 200	30 - 60
	Lime titania	2	70 - 100	30 - 60		Lime titania (2)	0.5	300 - 350	30 - 60
	High titania	3	70 - 100	30 - 60		Lime (2)	0.5	300 - 350	30 - 60
	Low hydrogen	0.5	300 - 350	30 - 60		High titania	3	70 - 100	30 - 60
Weather proof steel	Iron-powder titania	2	70 - 100	30 - 60	Hardfacing	Lime	0.5	300 - 350	30 - 60
	Low hydrogen	0.5	325 - 375	60		Lime	1	150 - 200	30 - 60
	Lime titania	0.5	350 - 400	60		Graphite	1	150 - 200	30 - 60
	Low hydrogen	2	70 - 100	30 - 60		Lime	0.5	300 - 350	30 - 60
High strength steel or low temperature steel	Low hydrogen	0.5	300 - 350	30 - 60	Cast iron	Graphite	1.5	70 - 100	30 - 60
	Lime titania	0.3-0.5	350 - 400	60		Lime titania type	1	150 - 200	30 - 60
	Low hydrogen	0.5	350-400	60		Lime type	1	200 - 250	30 - 60
	Low hydrogen	-	350 - 430	60					
Heat-resist. low-alloy steel	High titania	3	70 - 100	30 - 60					
	Low hydrogen	0.5	325 - 375	60					

Note: (1) For Cr-Ni type stainless steel  
 (2) For Cr type stainless steel

### 3.2 Wires for gas-shielded arc welding

#### 3.2.1 Scope of welding wires

As shown in Fig. 3.9, solid wires for gas-shielded arc welding include both those for gas shielded metal arc welding (MAG, MIG) and those for tungsten inert gas (TIG) arc welding. These wires can be further classified by the suitable shielding gas. In order to obtain intended wire usability and weld quality, an appropriate shielding gas must be selected according to the chemical composition of wire and the application. For example, CO<sub>2</sub> and Ar+CO<sub>2</sub> mixture are used for welding mild steel, high strength steel, and low alloy steel; Ar+2%O<sub>2</sub> for stainless steel, and pure Ar for nickel alloys. For MAG and TIG welding, flux-cored wires are also available.

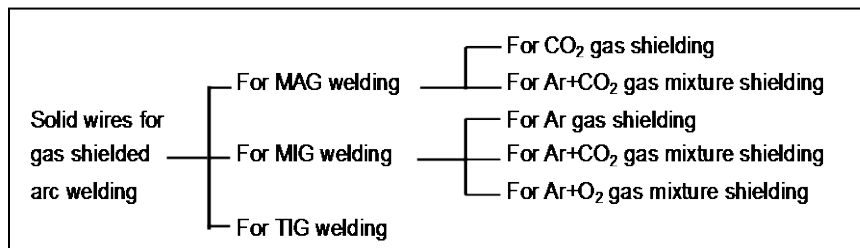

Fig. 3.9 — Scope of solid wires

#### 3.2.2 Features of MAG welding shielding gases

Although solid wires for CO<sub>2</sub> arc welding are widely used, they have such drawbacks as much spatter due to the globular transfer arc, inferior bead appearance, and difficulty in welding thin steel plates. These problems can be solved by the use of Ar+CO<sub>2</sub> gas mixtures or flux-cored wires. Fig. 3.10 compares the amounts of spatter tested with different mixing ratios of CO<sub>2</sub> and Ar gases for shielding. Clearly, a gas mixture of 80%Ar+20%CO<sub>2</sub> results in the least spatter generation as well as higher deposition efficiency. However, when a wire designed for CO<sub>2</sub> shielding is used with such a mixed gas, the amounts of Mn and Si in the deposited metal increase, resulting in increased tensile strength and hardness. Therefore, when a mixed gas is used, it is desirable to use the appropriate wires.

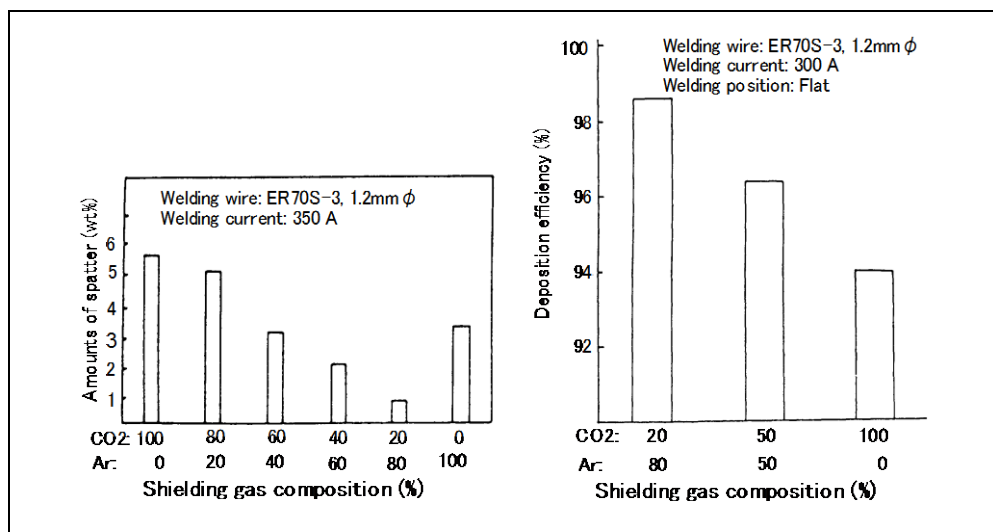

Fig. 3.10 — Relationship between spatter generation, deposition efficiency, and shielding gas compositions in welding with solid wires

### 3.2.3 Features of MIG welding shielding gases

For MIG welding of aluminum and titanium alloys, an inert gas of pure Ar is commonly used for shielding in order to prevent oxidation of the welds. In contrast, for welding stainless steels, Ar+O<sub>2</sub> gas mixtures containing a small percentage of O<sub>2</sub> are used. This is to stabilize the arc and improve the weld soundness. In welding low alloy steels, Ar+CO<sub>2</sub> gas mixtures containing a small percentage of CO<sub>2</sub> are used in order to stabilize the arc. Additions of O<sub>2</sub> or CO<sub>2</sub> in an Ar gas can cause oxidization of the alloying elements of the wire, decreasing the yield of these chemical elements into the deposited metal. However, when the maximum mixing ratio of O<sub>2</sub> or CO<sub>2</sub> is 2% or 5%, respectively, no remarkable oxidization will occur. Therefore, these gas mixtures are also classified as inert gases for MIG welding.

### 3.2.4 Features of TIG welding shielding gases

Pure Ar gas is generally used in TIG welding for shielding the tungsten electrode, molten droplets, and molten pool from the air to prevent them from oxidation; therefore, the deposited metal has almost the same chemical composition as that of the wire when the shielding is appropriate.

### 3.2.5 Production of wires

Several sectional shapes are available, as shown in Fig. 3.11, for the wires used in gas-shielded arc welding. These wires are classified into flux-cored wires and solid wires. Fig. 3.12 illustrates the typical production process for the solid wires for mild steel, high strength steel, and low-alloy steel. Solid wires for gas shielded metal arc welding are generally wound onto spools, while those for TIG welding are wound onto spools or cut into certain lengths. Fig. 3.13 shows the typical production process for flux-cored wires of the type (A) shown in Fig. 3.11.

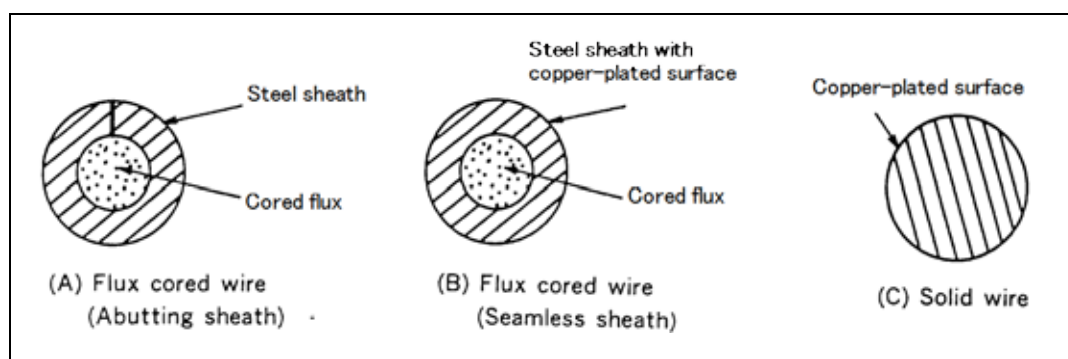

Fig. 3.11 — Examples of sectional shapes of wires for gas-shielded arc welding

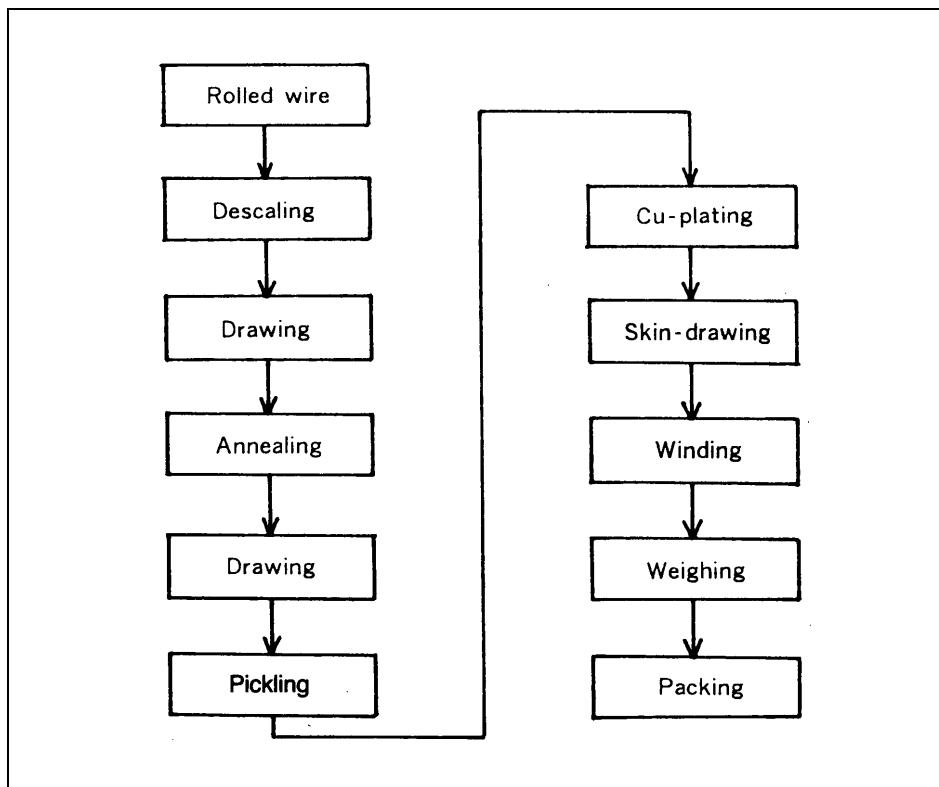

Fig. 3.12 — Typical production process for solid wires

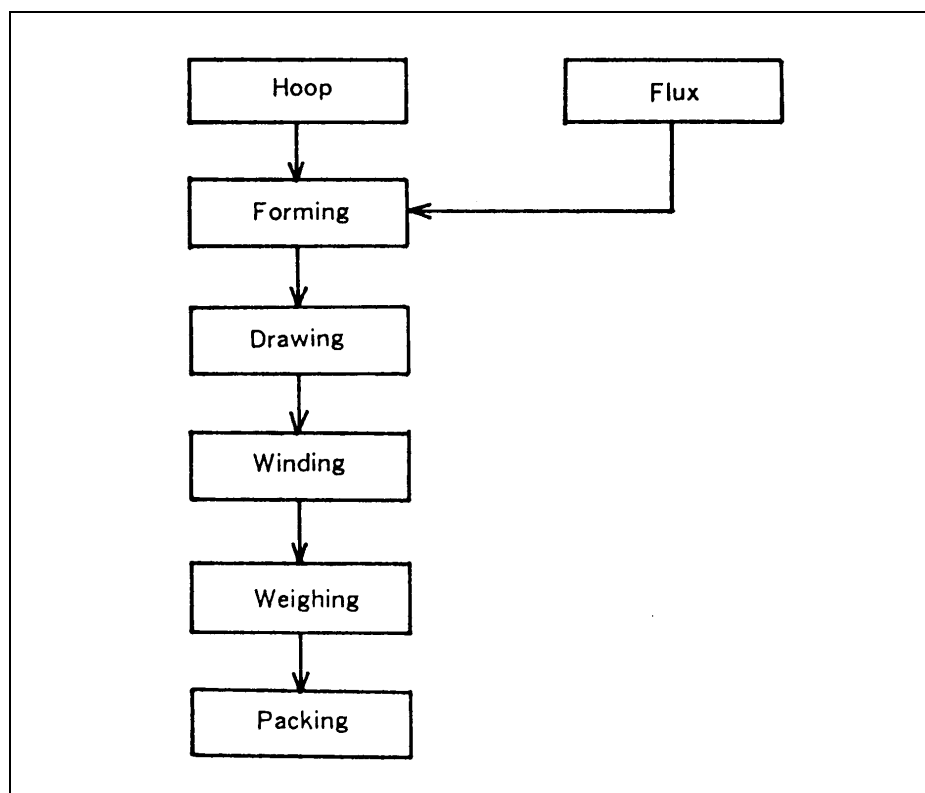

Fig. 3.13 — Typical production process for flux-cored wires

### 3.2.6 Types of wires

#### (1) Wires for MAG welding

Wires for MAG welding can be divided into solid wires and flux-cored wires. Table 3.9 shows some of the standards for solid wires and flux-cored wires: AWS A5.18:2005 (Carbon Steel Electrodes and Rods for Gas Shielded Arc Welding) and A5.20:2005 (Carbon Steel Electrodes for Flux Cored Arc Welding). The A5.18:2005 standard specifies solid wires for welding of mild steel and 490N/mm<sup>2</sup> high strength steel. The A5.20:2005 standard specifies flux-cored wires for welding of mild steel and 490N/mm<sup>2</sup> high strength steel. The following paragraphs describe the characteristics of the major classifications of both solid wires and flux-cored wires.

**A5.18 ER70S-2:** This type of solid wire is primarily used for single-pass welding of killed, semi-killed, and rimmed steel, but may be used for some multi-pass applications. Due to the effects of the added deoxidants (Ti, Zr, and Al), these wires can be used for welding steel materials that have a rusty or dirty surface, with a possible sacrifice of weld quality depending on the condition of the surface. The specified type of shielding gas is CO<sub>2</sub>; however, available wires can mostly be used with Ar+CO<sub>2</sub> gas mixture shielding.

**A5.18 ER70S-3:** This type of solid wire is intended for welding single-pass and multi-pass welds. The specified type of shielding gas is CO<sub>2</sub>; however, available wires can mostly be used with Ar+CO<sub>2</sub> gas mixture shielding.

**A5.18 ER70S-6:** This type of wire is intended for both single- and multiple-pass welding. It is especially suited for sheet metal applications where smooth weld beads are desired and for structural steel plates that have moderate amounts of rust or mill scale. The specified type of shielding gas is CO<sub>2</sub>; however, available wires can mostly be used with Ar+CO<sub>2</sub> gas mixture shielding.

**A5.18 ER70S-G:** For this type of wire, only tensile property requirements are specified. The wire suppliers, therefore, should be consulted for the composition, properties, characteristics, and intended use of this classification. This type of wire is intended for both single- and multi-pass applications. Available wires can mostly be used with CO<sub>2</sub> shielding and Ar+CO<sub>2</sub> gas mixture shielding.

**A5.20 E70T-1C and E70T-1M:** The E70T-1C wires are classified as using CO<sub>2</sub> shielding gas, whereas the E70T-1M wires are classified as using 75-80%Ar/balanced CO<sub>2</sub> gas mixture shielding. Both wires are designed for single- and multiple-pass welding in the flat and horizontal position. Spray transfer, low spatter loss, and flat bead contour characterize these wires.

**A5.20 E71T-1C and E71T-1M:** The E71T-1C wires are classified as using CO<sub>2</sub> shielding gas, whereas the E71T-1M wires are classified as using 75-80%Ar/balanced CO<sub>2</sub> gas mixture shielding. Both wires are designed for single- and multiple-pass welding in all positions. Spray transfer, low spatter loss, and flat bead contour characterize these wires.

**Table 3.9 — Standards for solid wires and flux-cored wires for MAG welding (Excerpted from AWS A5.18-2005 and A5.20-2005)**

Classification (1)	Chemical composition of solid wires, or chemical composition of deposited metal of flux-cored wires (%)													Shielding gas	Current type	
	C	Mn	Si	P	S	Cu	Ti	Zr	Al	Cr	Ni	Mo	V			
Solid wires (A5.18)	ER70S-2	0.07 max.	0.90-1.40	0.40-0.70	0.025 max.	0.035 max.	0.50 max.	0.05-0.15	0.02-0.12	0.05-0.15	0.15 max.	0.15 max.	0.15 max.	0.03 max.	CO <sub>2</sub>	DC-EP
		0.06-0.15	0.90-1.40	0.45-0.75												
		0.06-0.15	1.40-1.85	0.80-1.15												
Flux-cored wires (A5.20)	ER70S-G	(2)													(2)	(2)
	E70T-1C	0.12 max.	1.75 max.	0.90 max.	0.03 max.	0.35 max.	—	—	—	—	0.20 max.	0.50 max.	0.30 max.	0.08 max.	CO <sub>2</sub>	DC-EP
															Ar+CO <sub>2</sub> (3)	
															CO <sub>2</sub>	
E71T-1M													Ar+CO <sub>2</sub> (3)			

Classification	Mechanical properties of deposited metal			
	Tensile strength (ksi)	0.2% yield strength (ksi)	Elongation (%)	Charpy impact value (ft-lb)
Solid wires (A5.18)	70 min.	58 min.	22 min.	20 min. at -20°F
				20 min. at 0°F
				20 min. at -20°F
				(2)
Flux-cored wires (A5.20)	70-95	58 min.	22 min.	20 min. at 0°F

Note: (1) Classification system of A5.18 ERXXS-X:  
 E: Designates an electrode.  
 R: Designates a rod.  
 70: Indicates the minimum tensile strength.  
 S: Designates a solid wire.  
 The last digit: Indicates the chemical composition of a solid wire, whereas "G" stands for "general" classification.

Classification system of A5.20 EXXT-XX:  
 E: Designates an electrode.  
 7: Indicates the minimum tensile strength.  
 The third digit indicates intended welding position: 0 is for flat and horizontal position only, 1 is for all positions.  
 T: Designates a flux-cored wire.  
 1: Refers to the usability of the wire.  
 C: Indicates that the wire is classified as using CO<sub>2</sub>; M: Indicates that the wire is classified as using 75-80%Ar/balanced CO<sub>2</sub>.

(2) Requirements depend on an agreement between the manufacturer and purchaser (Ni, Cr, Mo and V shall not be alloyed intentionally).

(3) 75-80%Ar/balanced CO<sub>2</sub>



For MAG welding of low alloy steel, solid wires are specified in AWS A5.28:2005 (Low-Alloy Steel Electrodes and Rods for Gas Shielded Arc Welding), and flux-cored wires, in A5.29:2010 (Low-Alloy Steel Electrodes for Flux Cored Arc Welding). The A5.28:2005 standard covers solid wires for welding 550-830N/mm<sup>2</sup> high strength steel, low-temperature steel, and heat-resistant low-alloy steel. The A5.29:2010 standard covers flux-cored wires for welding low-temperature steel, high strength steel, and heat-resistant low-alloy steel. For MAG welding of stainless steel, flux-cored wires are specified in A5.22:2012 (Stainless Steel Flux Cored and Metal Cored Welding Electrodes and Rods).

### **(2) Wires for MIG welding**

The A5.28:2005 standard mentioned above also specifies solid wires for MIG welding of heat-resistant low-alloy steel, low-temperature steel, and high strength steel. As for MIG welding of stainless steel, AWS A5.9:2012 (Bare Stainless Steel Welding Electrodes and Rods) specifies solid wires. Solid wires are specified for MIG welding of nickel and nickel alloys in AWS A5.14:2011 (Nickel and Nickel Alloy Bare Welding Electrodes and Rods). For MIG welding of copper and copper alloys, solid wires are specified in AWS A5.7:2007 (Copper and Copper Alloy Bare Welding Rods and Electrodes).

### **(3) Wires for TIG welding**

Wires for TIG welding are also included in the above-mentioned AWS standards. Solid wires are specified in AWS A5.18:2005 for welding of carbon steel. For welding of low-alloy steel, solid wires are specified in AWS A5.28:2005. For welding of stainless steel, solid wires are specified in AWS A5.9:2012. As for flux-cored rods, AWS A5.22:2012 specifies them for welding of stainless steel. Solid wires are specified in AWS A5.14:2011 for welding of nickel and nickel alloys. For welding of copper and copper alloys, solid wires are specified in AWS A5.7:2007.

Flux-cored wires for TIG welding are designed to be used without Ar gas back-shielding for the root pass in one-side welding of tubes and pipes. In TIG welding, the fused flux becomes slag, and the slag covers the reverse-side bead, thereby preventing oxidation.

## **3.3 Wires for self-shielded arc welding**

Self-shielded arc welding is also known as "non-gas shielded arc welding". Specially designed flux-cored wires are used in this welding process without any external shielding gas. In self-shielded arc welding, the cored flux generates the shielding gas to protect the molten pool. The other ingredients in the cored flux are deoxidizers, denitrifying components, arc stabilizers, and slag components. This type of wire has larger diameters (2.4 and 3.2 mm) than wires for MAG and MIG welding. These larger-size wires use the AC drooping type power sources in the flat and horizontal positions. Recently, wires with smaller sizes of 1.6 and 2.0 mm are also available, which are suited for out-of-position welding by using the DC constant voltage power sources (DC-EN polarity). AWS A5.20:2005 mentioned above also includes specifications for self-shielded arc welding wires. Self-shielded arc welding offers stable quality even in a strong wind of up to 15 m/sec. This type of wire, therefore, is useful particularly in outdoor welding.

### 3.4 Wires, strips, and fluxes for submerged arc welding

#### 3.4.1 The basics of wires, strips, and fluxes

While the function of wires and strips in submerged arc welding (SAW) is similar to that of covered electrode core wires in shielded metal arc welding, fluxes must be supplied separately in SAW. A variety of combinations of different types of wires, strips, and fluxes are available.

##### (1) Wires and strips

SAW uses solid wires, flux-cored wires, and strips. Fig. 3.14 shows the types and applications of these wires and strips.

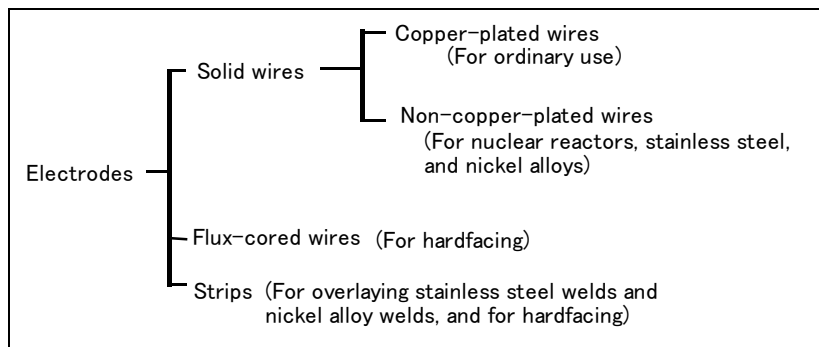

**Fig. 3.14 — A classification of electrodes (wires and strips) for submerged arc welding, and their intended applications**

The diameters of the most commonly used wires range from 2.4 to 6.4 mm. Small sizes of 1.6 and 2.0 mm are also available for specific applications. Fig. 3.15 shows the typical production process for solid wires for SAW of mild steel, high strength steel, and low-alloy steel. SAW wires are wound into a coil or onto a spool as shown in Fig. 3.16. Those of 2.0 mm or larger diameters are supplied in coils, while 1.6 mm diameter wires are supplied in spools. Cardboard drum package or pail pack (Arrow Pack) is also available for wires of 0.8, 0.9, 1.0, 1.2, 1.4, and 1.6 mm diameters.

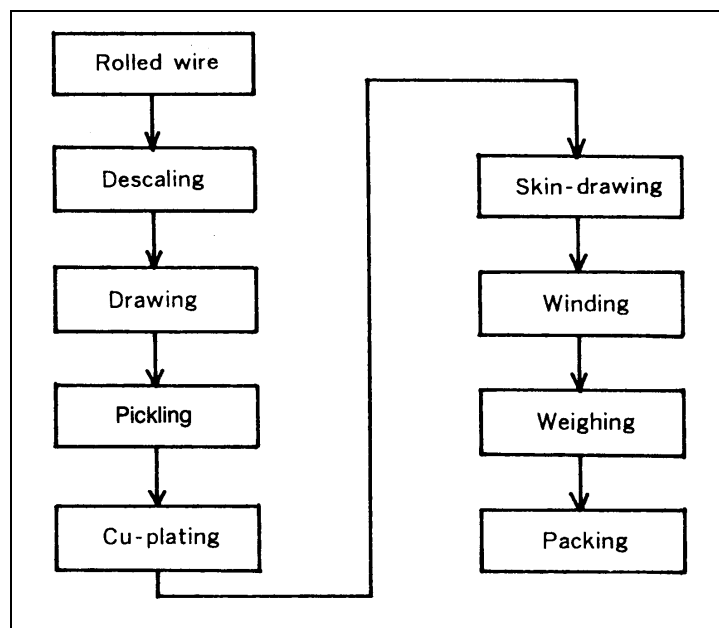

**Fig. 3.15 — Typical production process for solid wires for submerged arc welding**

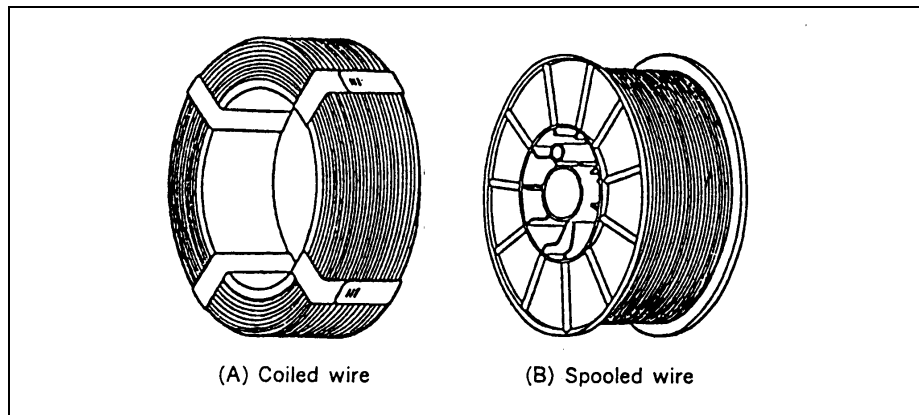

Fig. 3.16 — Typical types of wire packaging

**(2) Fluxes**

Fluxes for submerged arc welding are used to stabilize and shield the arc and produce metallurgical reactions in welding. They can be divided into fused, bonded, and agglomerated fluxes by the difference in production method. As shown in Fig. 3.17, fused fluxes are produced by melting raw materials, which are then cooled in glass-like state in the air, crushed, and sieved for adjusting the particle size. Fused fluxes are used for single and multi-pass welding of mild steel, high strength steel, and low-alloy steel, and have the following advantages:

- a) Suitable for high-speed welding of thin steel plates
- b) Little moisture absorption due to glassy particles
- c) Good in usability at welding currents of up to 1000 A
- d) Applicable to various types of steel (in combination with appropriate wires)
- e) Applicable to a wide range of welding currents due to a variety of particle sizes available

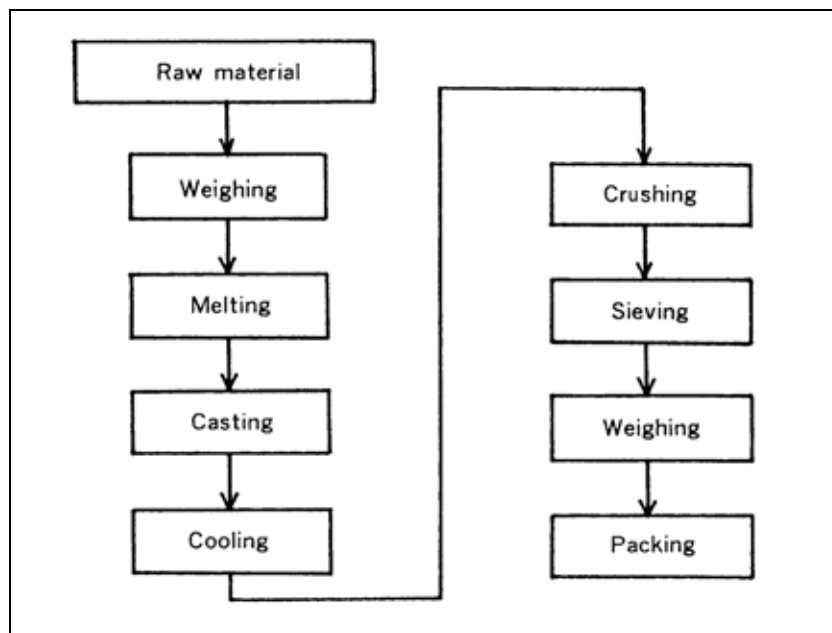
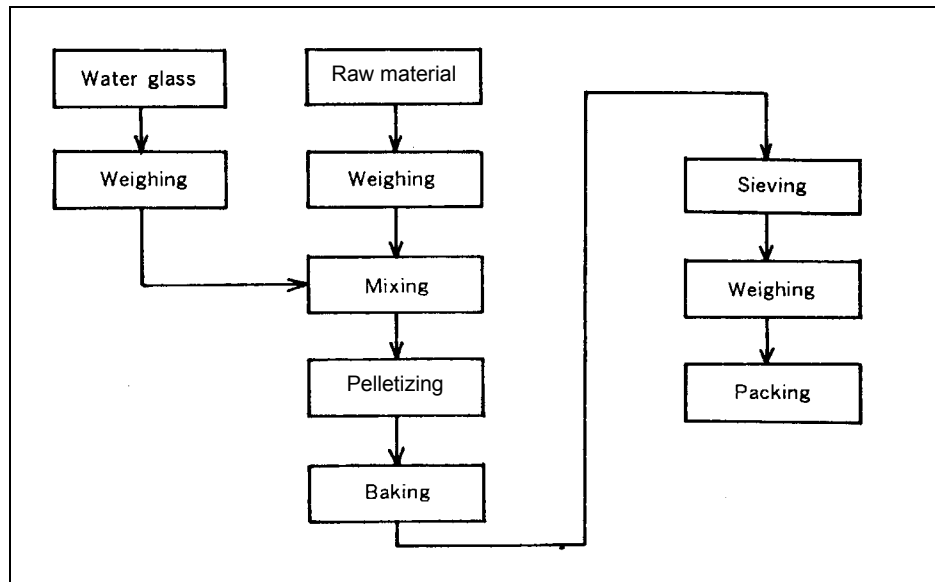

Fig. 3.17 — Typical production process for fused fluxes for submerged arc welding

Bonded fluxes are produced by baking a pelletized mixture of powdered raw materials and bonding agents at a temperature of 400 to 600°C. Fig. 3.18 shows the typical production process for bonded fluxes. Since bonded fluxes are not melted in the production process, it is possible to add deoxidizers and alloying elements into the flux.



**Fig. 3.18 — Typical production process for bonded fluxes for submerged arc welding**

Bonded fluxes are often used for one-side welding of mild steel, using high currents. In addition, 490N/mm<sup>2</sup> high strength steel, low-alloy steel, and stainless steel also use bonded fluxes. A higher tendency of absorbing moisture is a disadvantage of bonded fluxes. Therefore, redrying is a must before use. Bonded fluxes offer the following advantages:

- a) Low-hydrogen welds can be obtained.
- b) Si and Mn can be added for deoxidization.
- c) Alloying elements can be added to adjust the chemical and mechanical properties of the weld metal.
- d) Good usability can be assured at both higher welding currents than 1000A and lower currents.
- e) The consumption of flux can be conserved due to lower flux consumption ratios to obtain a particular amount of weld metal as compared with fused fluxes.

### 3.4.2 Types of wires and fluxes

Submerged arc welding is performed with a combination of wire and flux. Since high currents are employed in submerged arc welding, the weld penetration is quite deep. The chemical composition of the base metal tends to affect the chemical composition of the weld metal because of deep penetration. Therefore, a suitable combination of wire and flux should be determined through testing their performance on the steel material to be used in advance. Standards generally specify wires, fluxes, and deposited metals. AWS A5.17:97(R2007) (Carbon Steel Electrodes and Fluxes for Submerged Arc Welding) specifies the wires and fluxes for welding of mild steel and 490-N/mm<sup>2</sup>-class high strength steel. Table 3.10 shows

excerpts from the specification of A5.17:97(R2007). AWS A5.23:2011 (Low Alloy Steel Electrodes and Fluxes for Submerged Arc Welding) specifies the wires and fluxes for welding of heat-resistant low-alloy steel, low-temperature steel, and high strength steel. Stainless steel wires for submerged arc welding are specified in AWS A5.9:2012 (Bare Stainless Steel Welding Electrodes and Rods).

**Table 3.10 — Classifications and requirements for submerged arc welding wires and fluxes excerpted from AWS A5.17:97(R2007)**

Classification (1)		Chemical composition of wire (%)						
		C	Mn	Si	S	P	Cu	Others
Wires	EL8	0.10 max.	0.25- 0.60	0.07 max.	0.030 max.	0.030 max.	0.35 max.	0.50 max.
	EL12	0.04- 0.14	0.25- 0.60	0.10 max.				
	EM12K	0.05- 0.15	0.80- 1.25	0.10- 0.35				
	EH14	0.10- 0.20	1.70- 2.20	0.10 max.				

Classification (2)		Mechanical properties of weld metal			
		Tensile strength (ksi)	0.2% proof strength (ksi)	Elongation (%)	Charpy impact energy (ft-lbf)
Fluxes	F7A0-EXXX	70-95	58 min	22 min.	20 min. at 0° F
	F7A2-EXXX				20 min. at -20° F
	F7A6-EXXX				20 min. at -60° F
	F7P6-EXXX				20 min. at -60° F

Note (1) Classification system of EXXX

- E: designates an electrode
- L: indicates low manganese content
- M: indicates medium manganese content
- H: indicates high manganese content
- 8: indicates the nominal carbon content: 0.08
- 12: indicates the nominal carbon content: 0.12
- 14: indicates the nominal carbon content: 0.14
- K: indicates that the electrode is made from a heat of silicon killed steel

(2) Classification system of FXXX-EXXX

- F: designates a virgin flux
- 7: represents the minimum tensile strength of the weld metal in 70 ksi
- A: indicates that the weld metal was tested in the as-welded condition
- P: indicates that the weld metal was tested after postweld heat treatment
- 0: designates 0 degree Fahrenheit as the temperature at which the weld metal meets the required 20 ft-lbf Charpy V-notch impact strength
- 2: designates -20 degrees Fahrenheit as the temperature at which the weld metal meets the required 20 ft-lbf Charpy V-notch impact strength
- 6: designates -60 degrees Fahrenheit as the temperature at which the weld metal meets the required 20 ft-lbf Charpy V-notch impact strength

EXXX: refers to the electrode classification with which the flux will deposit weld metal that meets the specified mechanical properties when tested as called for in the specification

## 4. Welding Design and Fabrication

Structures fabricated by welding should be suited to their usage and fully live up to their expected qualities. On the other hand, the costs of welding fabrication should be kept as low as possible. The realization of such goals or plans is called welding design. In order to obtain weld joints with acceptable qualities that conform to the requirements and the purposes of design, welding work should be carried out in accordance with an appropriate plan and welding procedure.

### 4.1 Welding joints and grooves

The shape of welding joints can be various depending on the plate thickness and the design of a structure to be welded. The principle types of weld joints are shown in Fig. 4.1. The welding joint has a channel to be filled with deposited metal. This channel is called a groove. The groove should be narrow enough to minimize welding work, but wide enough to prevent the occurrence of welding defects. Fig. 4.2 shows the most commonly used types of grooves. Fig. 4.3 defines the terminology for parts of various types of grooves.

In the case of a butt joint, its groove shape commonly varies from Square  $\Rightarrow$  Single-V  $\Rightarrow$  Double-V  $\Rightarrow$  Single-U  $\Rightarrow$  Double-U as the plate becomes thicker in order to reduce the mass to be filled with deposited metal. It is also necessary to select a groove suitable for the welding process and welding position. Butt joints can basically transmit the strength most effectively and are employed in various applications. A T-joint is most often used for assembling structures. There are two cases for using a T-joint: one is to transmit the shearing strength, another is to transmit the tensile strength. Other than the principle types of joint shown in Fig. 4.1, some variations are used depending on the structure as shown in Fig 4.4. Fig. 4.5 shows variations of welds.

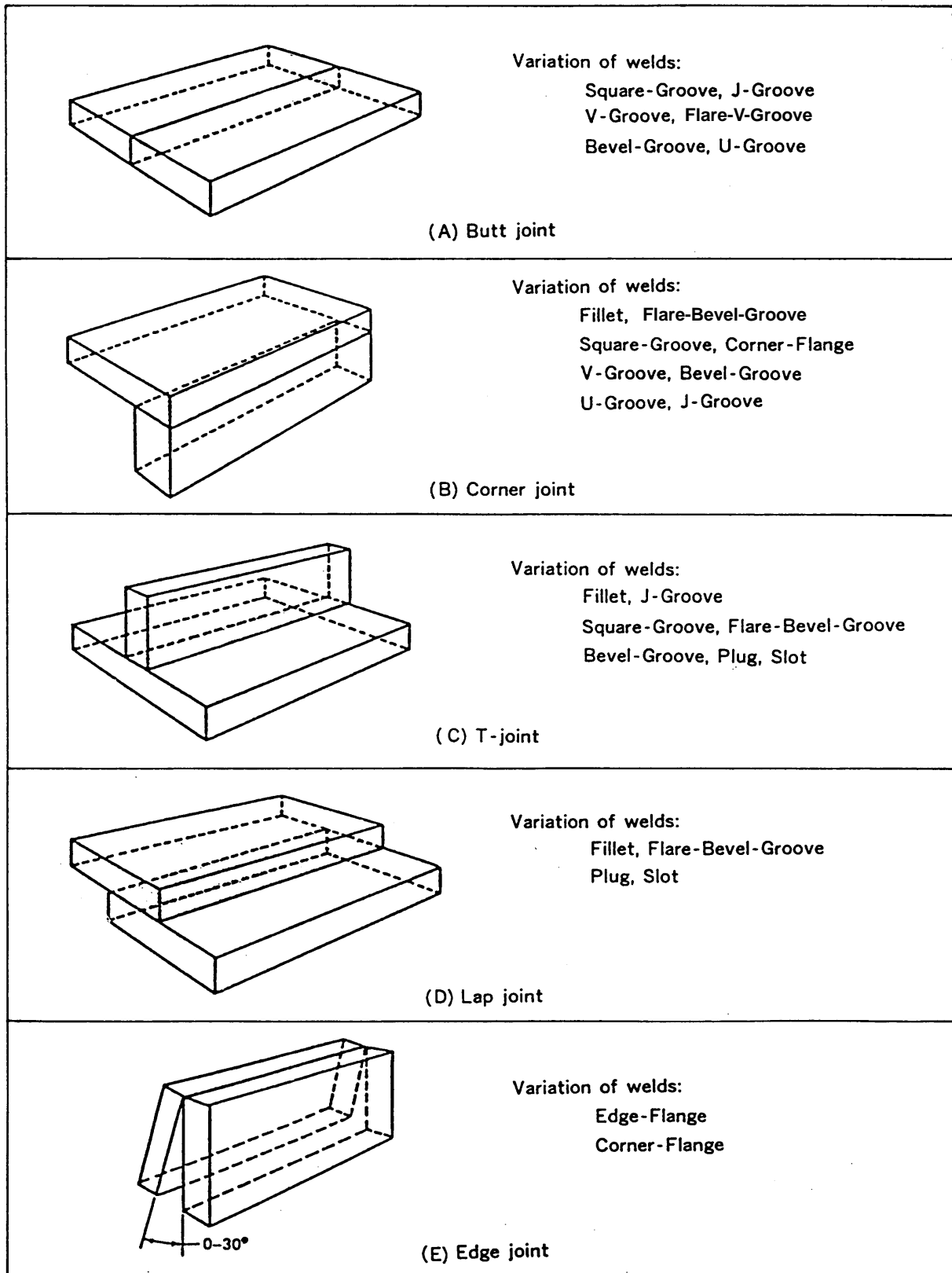

Fig. 4.1 — Typical welding joints (Source: AWS A3.0:1989)

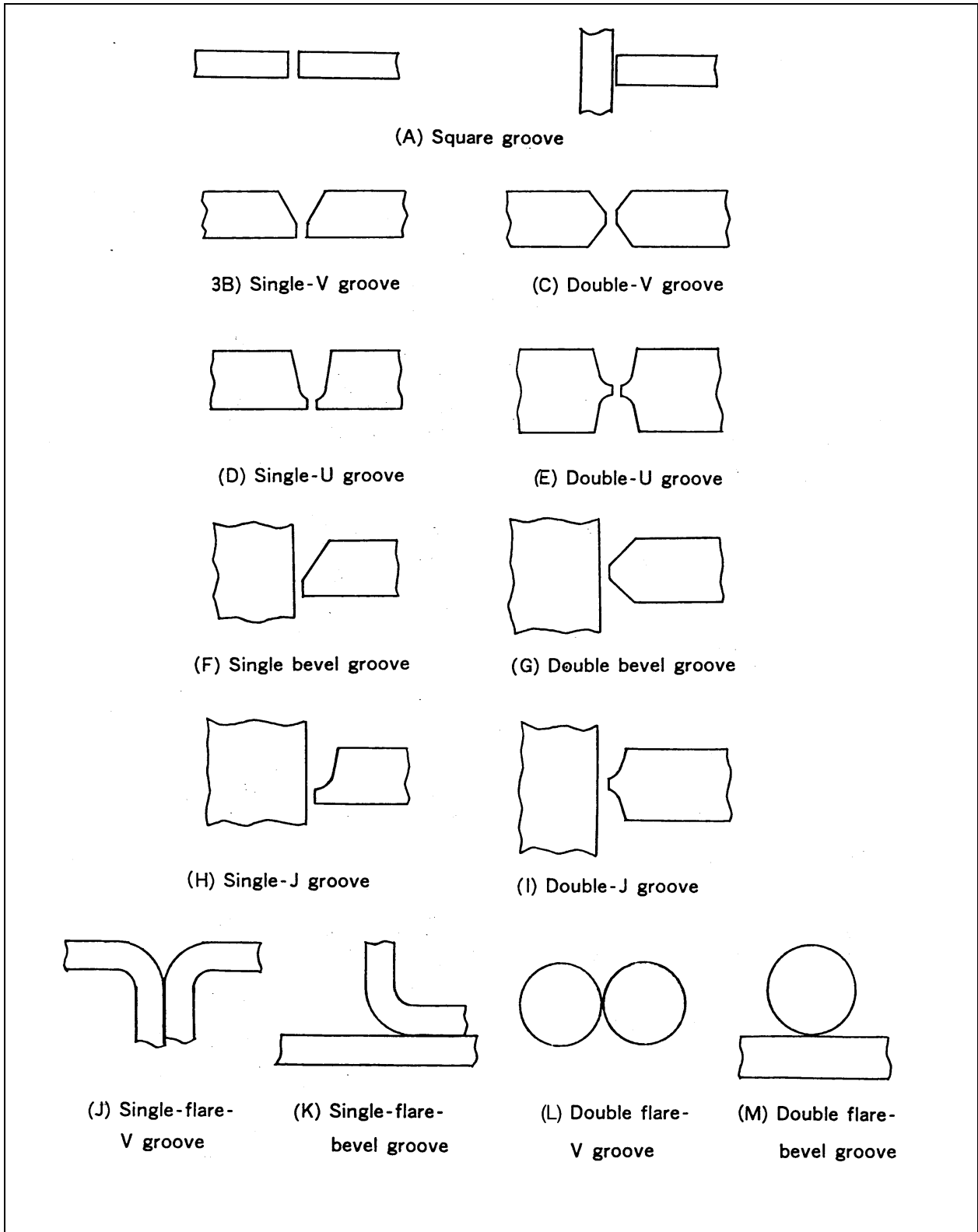

Fig. 4.2 — A variety of welding grooves



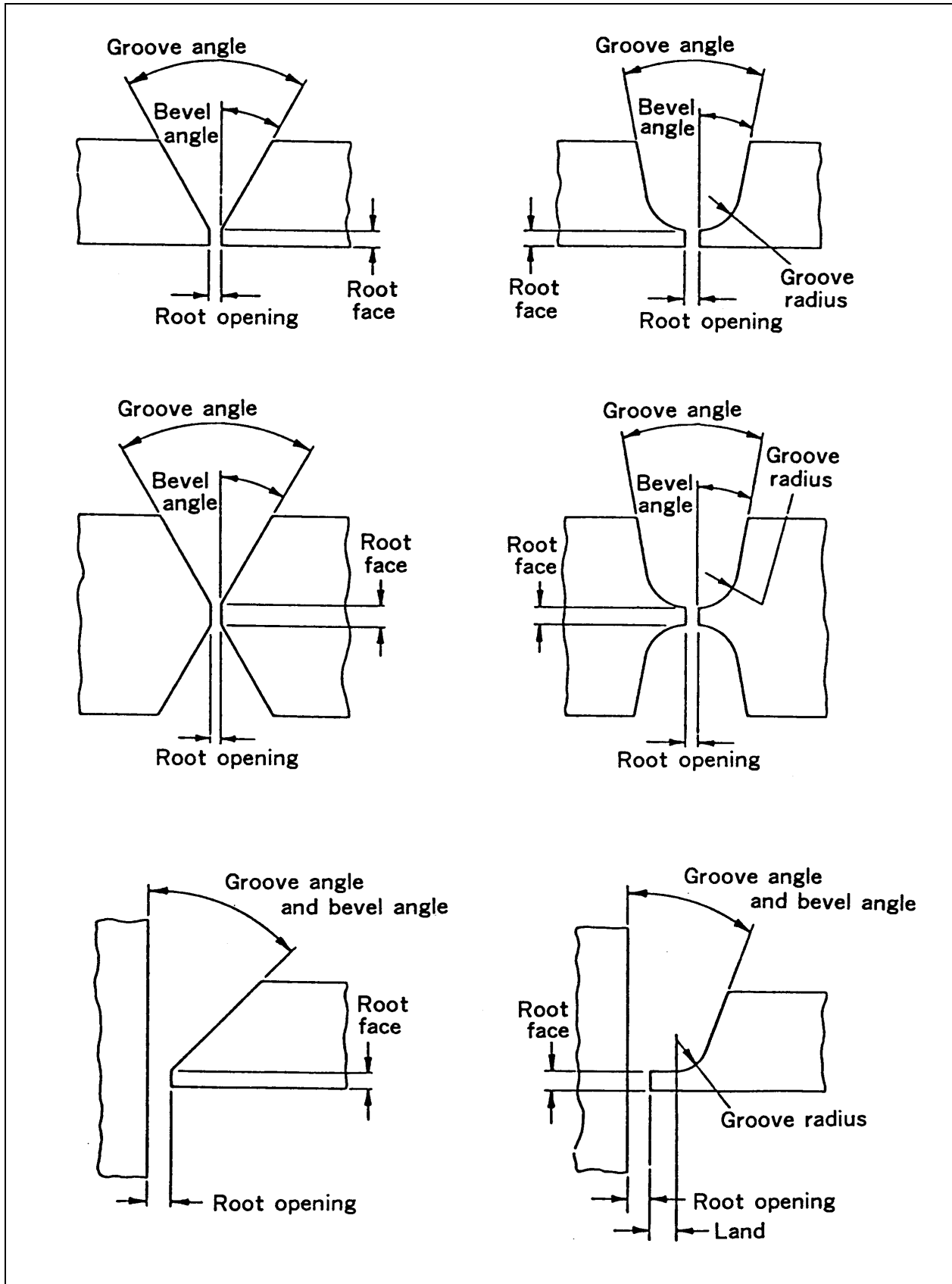

Fig. 4.3 — Definition of the groove parts

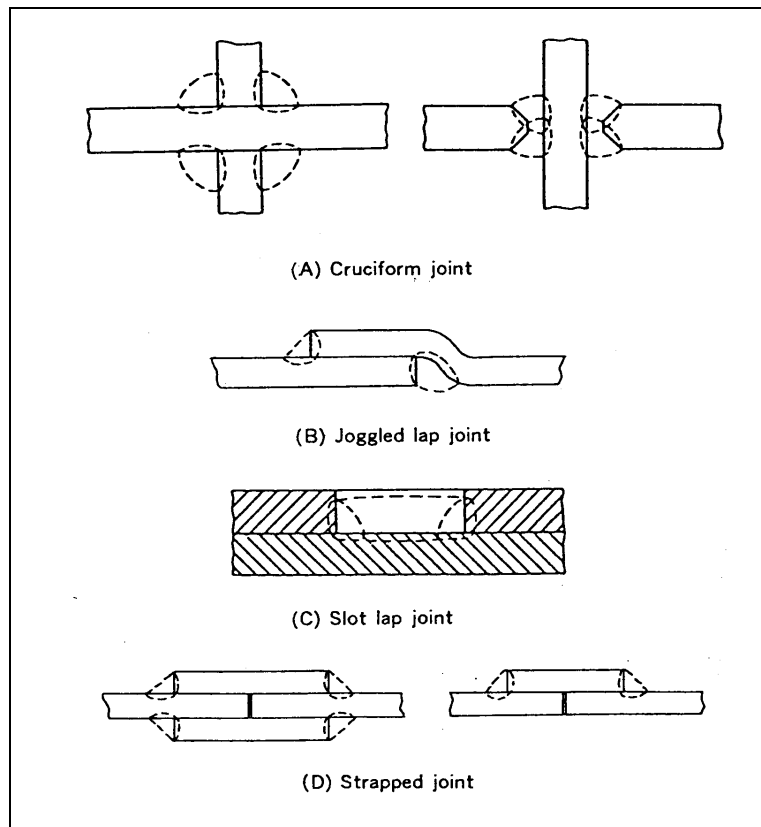

Fig. 4.4 — Variations of welding joints

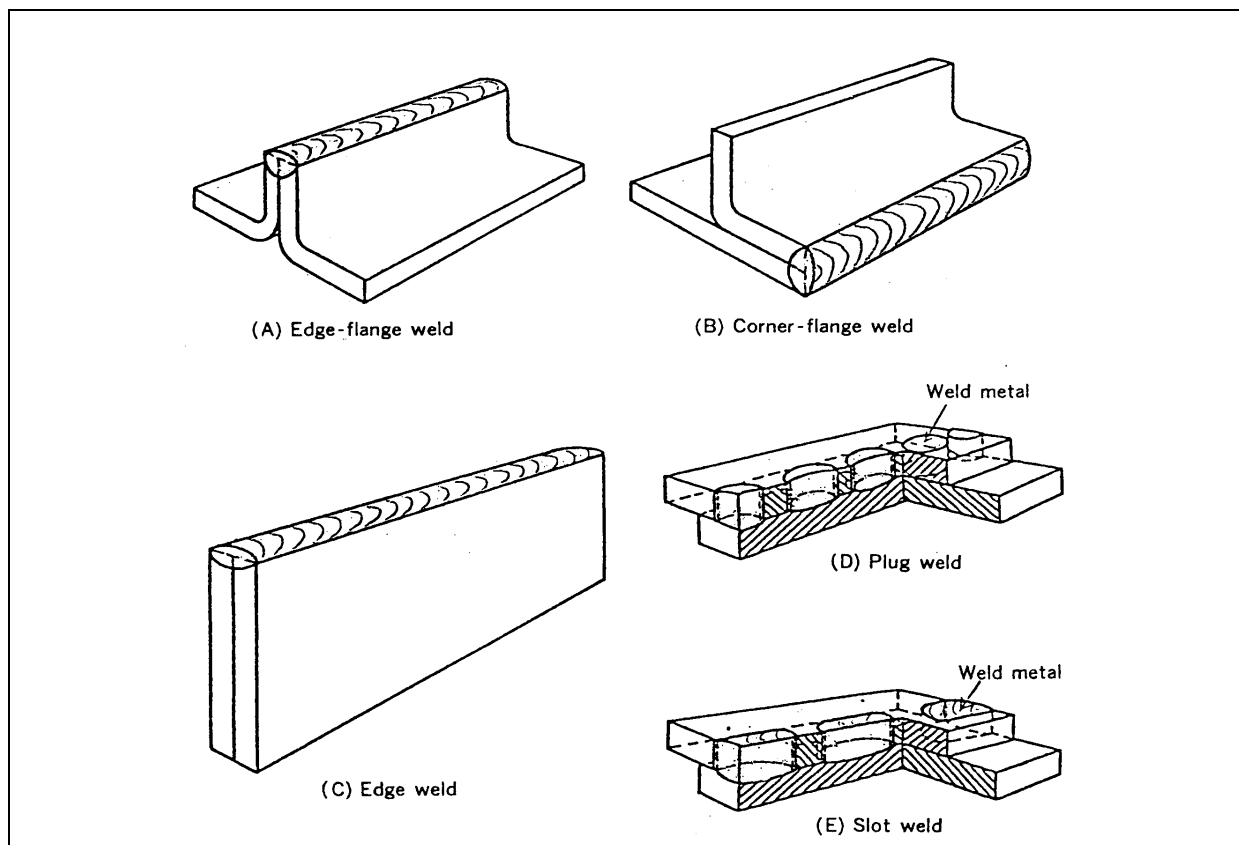

Fig. 4.5 — Variations of welds

### 4.2 Strength of welded joints

On designing the welding joint of a structure to be fabricated, several types of strength may have to be taken into consideration: tensile strength, impact strength, fatigue strength, and creep-rupture strength, depending on the requirements. In general, a welding joint is designed so that it satisfies the same requirements as those for the base metal. Therefore, the designer is expected to be acquainted with the properties of both steel materials and weld metals. Table 4.1 shows examples of the properties of steel materials specified by the Japanese Industrial Standards (JIS). The properties of weld metals were discussed in the previous chapter. This chapter discusses only the fundamentals of the static strength of weld joints.

**Table 4.1 — Requirements for rolled steels for welded structures (JIS G 3106-2008)**

Classification	Mechanical properties						
	Yield point (N/mm <sup>2</sup> )			Tensile strength (N/mm <sup>2</sup> ) t ≤ 100	Elongation (%)		Charpy impact value (J) at 0°C
	t ≤ 16	16 < t ≤ 40	40 < t ≤ 75		5 < t ≤ 16	16 < t ≤ 50	
SM400A	245 min.	235 min.	215 min.	400-510	18 min.	22 min.	—
SM400B							27 min.
SM400C							47 min.
SM490A	325 min.	315 min.	295 min.	490-610	17 min.	21 min.	—
SM490B							27 min.
SM490C							47 min.

Classification	Chemical composition (%)				
	C	Si	Mn	P	S
SM400A	t ≤ 50: 0.23 max. 50 < t ≤ 200: 0.25 max.	—	2.5 x C min.	0.035 max.	0.035 max.
SM400B	t ≤ 50: 0.20 max. 50 < t ≤ 200: 0.22 max.	0.35 max.	0.60-1.50	0.035 max.	0.035 max.
SM400C	t ≤ 100: 0.18 max.	0.35 max.	0.60-1.50	0.035 max.	0.035 max.
SM490A	t ≤ 50: 0.20 max. 50 < t ≤ 200: 0.22 max.	0.55 max.	1.65 max.	0.035 max.	0.035 max.
SM490B	t ≤ 50: 0.18 max. 50 < t ≤ 200: 0.20 max.	0.55 max.	1.65 max.	0.035 max.	0.035 max.
SM490C	t ≤ 100: 0.18 max.	0.55 max.	1.65 max.	0.035 max.	0.035 max.

The calculation of strength should be based upon the allowable stress. The maximum safety load is defined as an applied load by which the stress of the structure reaches the allowable stress. Although it is difficult to precisely compute stresses raised in a weld joint, the computation can be made by using the following method, provided the weld zone is uniformly stressed. Where the weld has convex reinforcement, the stresses raised around the weld are concentrated at the toes of the weld. The concentrated stresses can reach 1.3-1.8 times the stresses raised at other parts of the weld in the case of butt welds, according to experimental results. In the case of front fillet welds, the concentrated stresses can reach 2-5 times; further, at the root of a front fillet weld, the stress concentration can reach 6-7 times those of other portions in the weld. These stress concentrations affect fatigue strength rather

than static strength. The stresses raised in a weld by an applied load can be calculated according to the following formula for a groove weld and fillet weld:

$$\sigma = \frac{P}{\Sigma a \ell}, \quad \tau = \frac{P}{\Sigma a \ell}$$

where

- $\sigma$  : Tensile or compressive stress in the throat section
- $\tau$  : Shearing stress in the throat section
- P : Applying load
- a : Throat thickness
- $\ell$  : Effective weld length
- $\Sigma a \ell$  : Total area of the throat section

For determining throat thickness, the following methods are used:

**(1) Groove weld**

As illustrated in Fig. 4.6 (A), the throat thickness of a complete joint penetration weld is defined to be the thickness of the base metal. Where the weld joint consists of base metals with dissimilar thicknesses, the smaller thickness is used for the throat thickness. The size of the reinforcement is not included in the size of the throat. In the case of welds that have partial penetration, the throat thickness is defined as the joint penetration or the total size of the joint penetration where the weld is made on both sides of the joint as shown in Fig. 4.6 (B).

**(2) Fillet weld**

The throat thickness of a fillet weld in the structural components placed at a right angle is determined by the following formula. The "S" is the size of a fillet weld as in Fig. 4.6 (C).

$$a = \frac{S}{\sqrt{2}} \approx 0.7 S$$

When a fillet weld has unequal sizes, the smaller size is used for the calculation. Where a pair of components do not make right angles, the following formula is used to determine the throat thickness, where " $\theta$ " is the angle at which a pair of components make a skewed tee joint.

$$a = S \cos \frac{\theta}{2}$$

However, " $\theta$ " should be limited to  $60^\circ \leq \theta \leq 120^\circ$ , because where " $\theta$ " is out of this range, the transmission of the applied force cannot be expected. As stated above, the strength of a fillet weld is determined by using the throat thickness which is calculated using the size of the fillet. However, the size can be substituted by the leg length of the fillet, because the leg length is roughly equal to the size of the fillet. In practice, the throat thickness can be approximately 0.7 times the leg length. Fig. 4.7 shows definitions of fillet weld sizes.

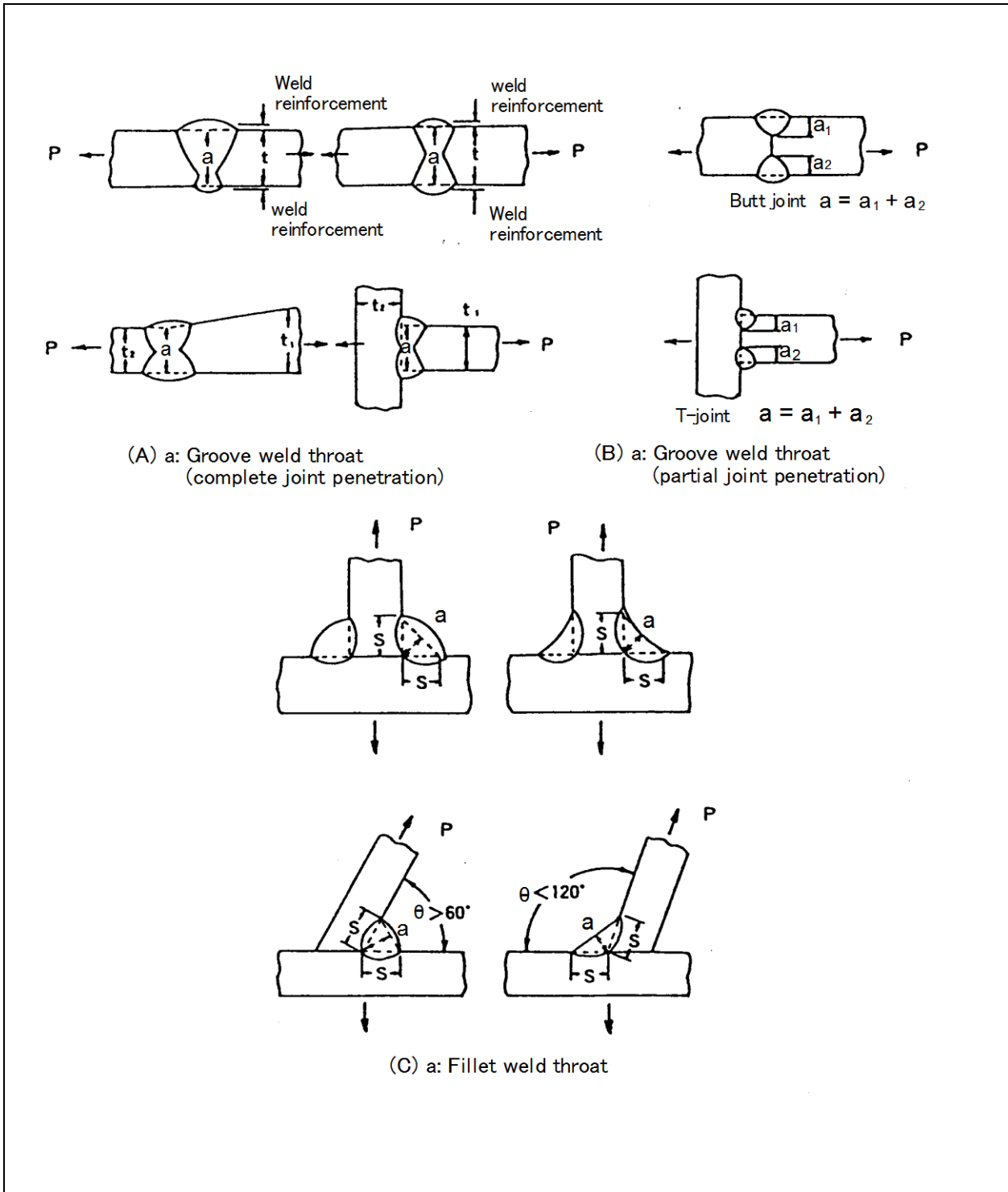

Fig. 4.6 — Definition of throat thickness of welds

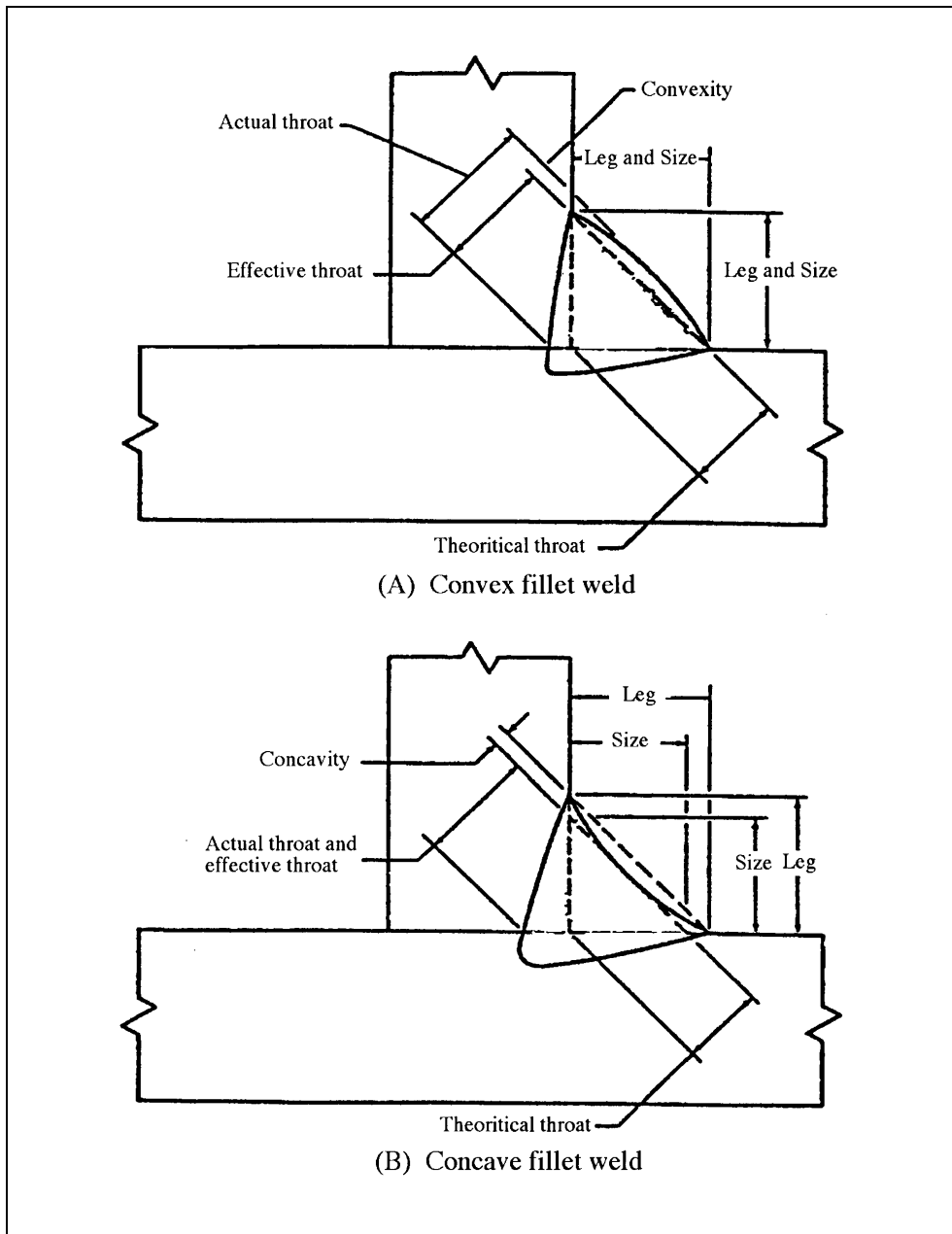

Fig. 4.7 — Fillet weld sizes (Source: AWS A3.0:1989)

### 4.3 Symbols for welding

In general, expected welds are shown on fabrication drawings with representations called "welding symbols." Figs. 4.8 and 4.9 show examples of the welding symbols used to represent butt joints and fillet joints, respectively. Welding symbols convey the design requirements to the workshop in a concise manner. A welding symbol can be used to specify the type of weld, groove design, weld size, welding process, face and root contours, operation sequence, weld length, and other information. For the latest information, refer to JIS Z3021:2010 (Welding and Allied Processes — Symbolic Representation), or AWS A2.4:2012 (Standard Symbols for Welding, Brazing, and Nondestructive Examination).

No.	Weld contour	Welding symbol
1		
2		
3		
4		
5		

Fig. 4.8 — Examples of welding symbols (Groove welds)

No.	Weld contour	Welding symbol
1		
2		
3		
4		
5		

Fig. 4.9 — Examples of welding symbols (Fillet welds)

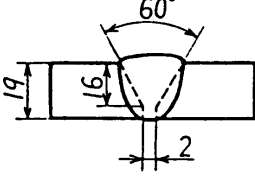
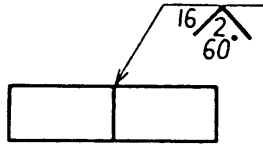
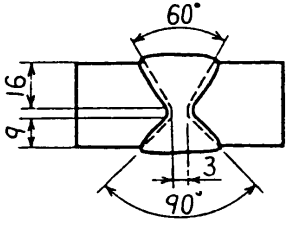
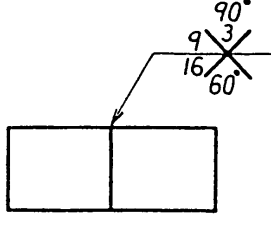
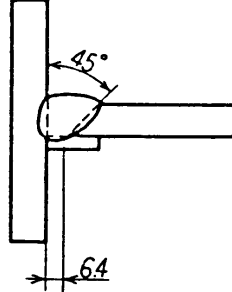
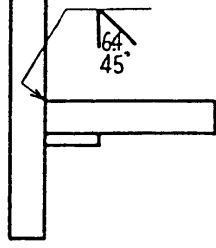
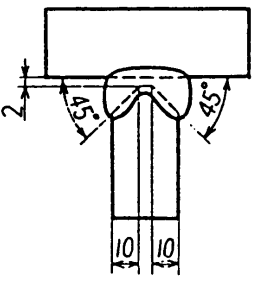
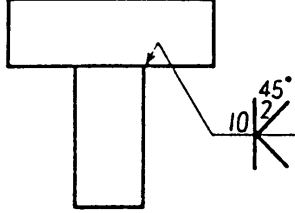
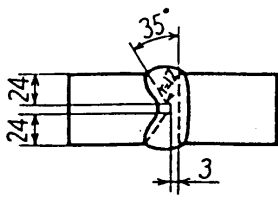
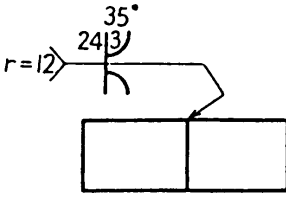

#### 4.4 Welding positions

Welding positions are illustrated in Figs. 4.10, 4.11, and 4.12. Each welding position is identified by the symbol in the parenthesis in accordance with the provision of ASME sec. IX:2001. The quality of welds and the work efficiency in vertical and overhead welding are generally inferior to those in flat welding. Therefore, welding should be carried out in the flat position as much as possible by positioning the work. Fig. 4.13 illustrates an example of positioning.

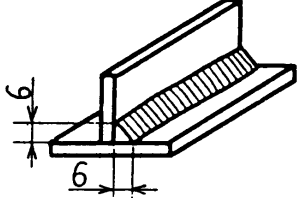
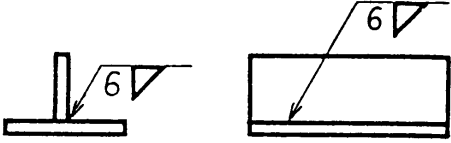
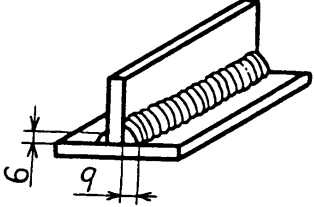
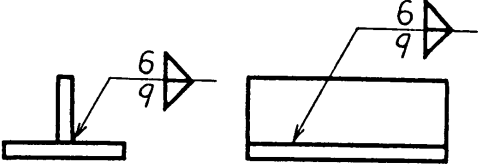
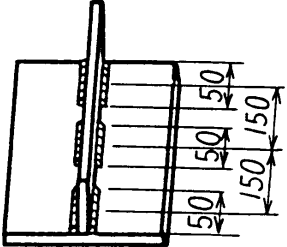
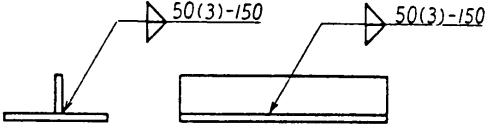
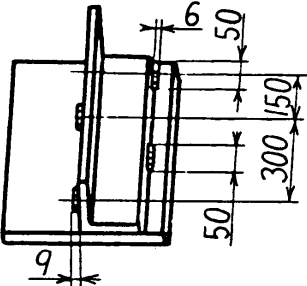
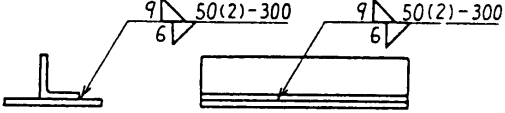
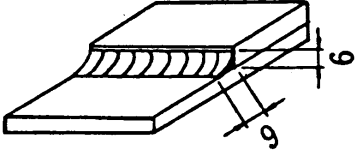
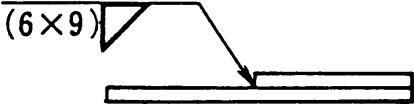
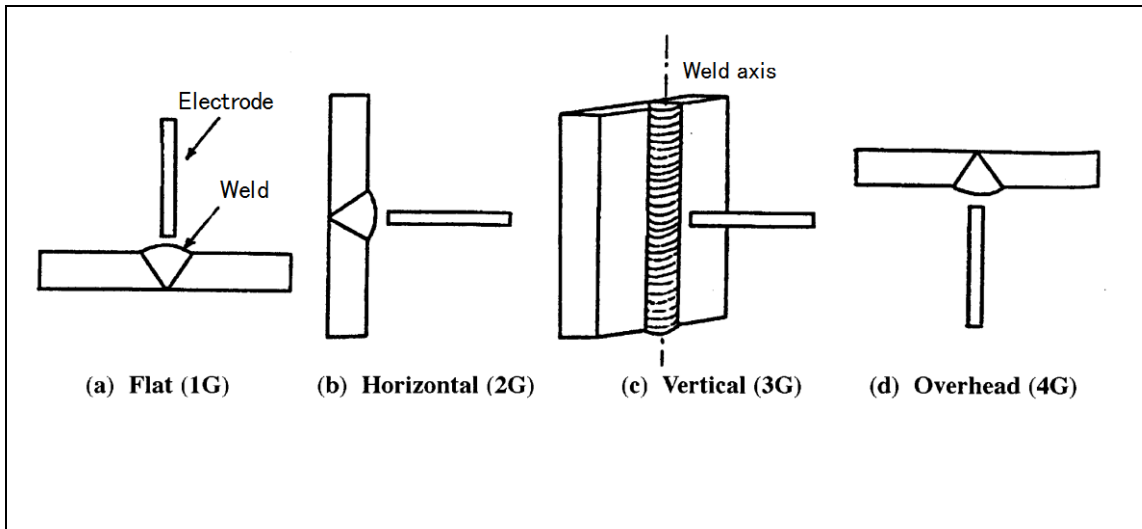

Fig. 4.10 — Welding positions used for groove welds

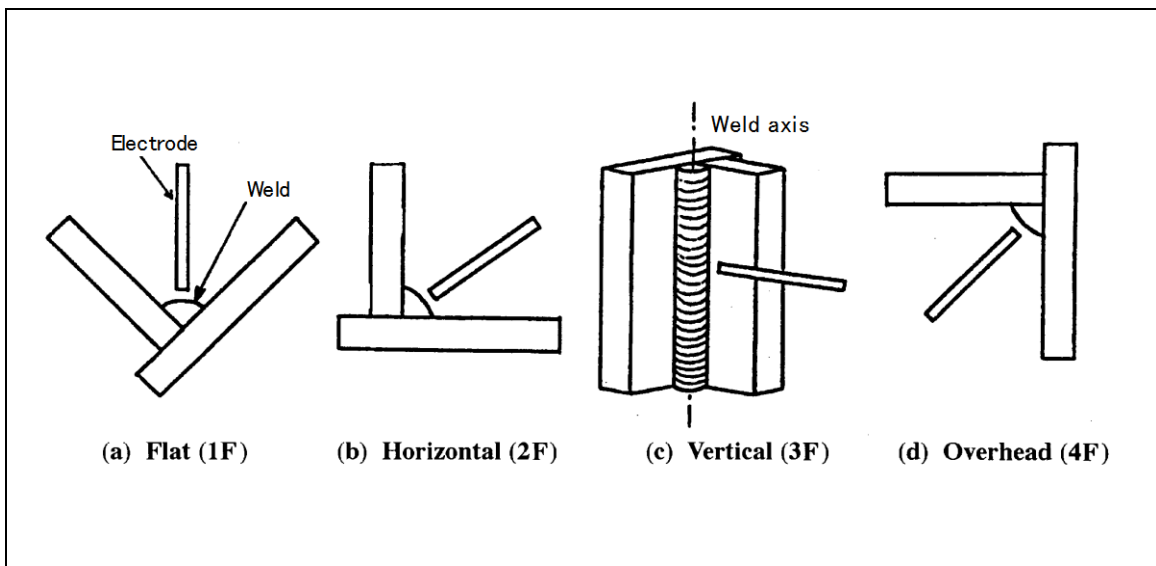

Fig. 4.11 — Welding positions for fillet welds

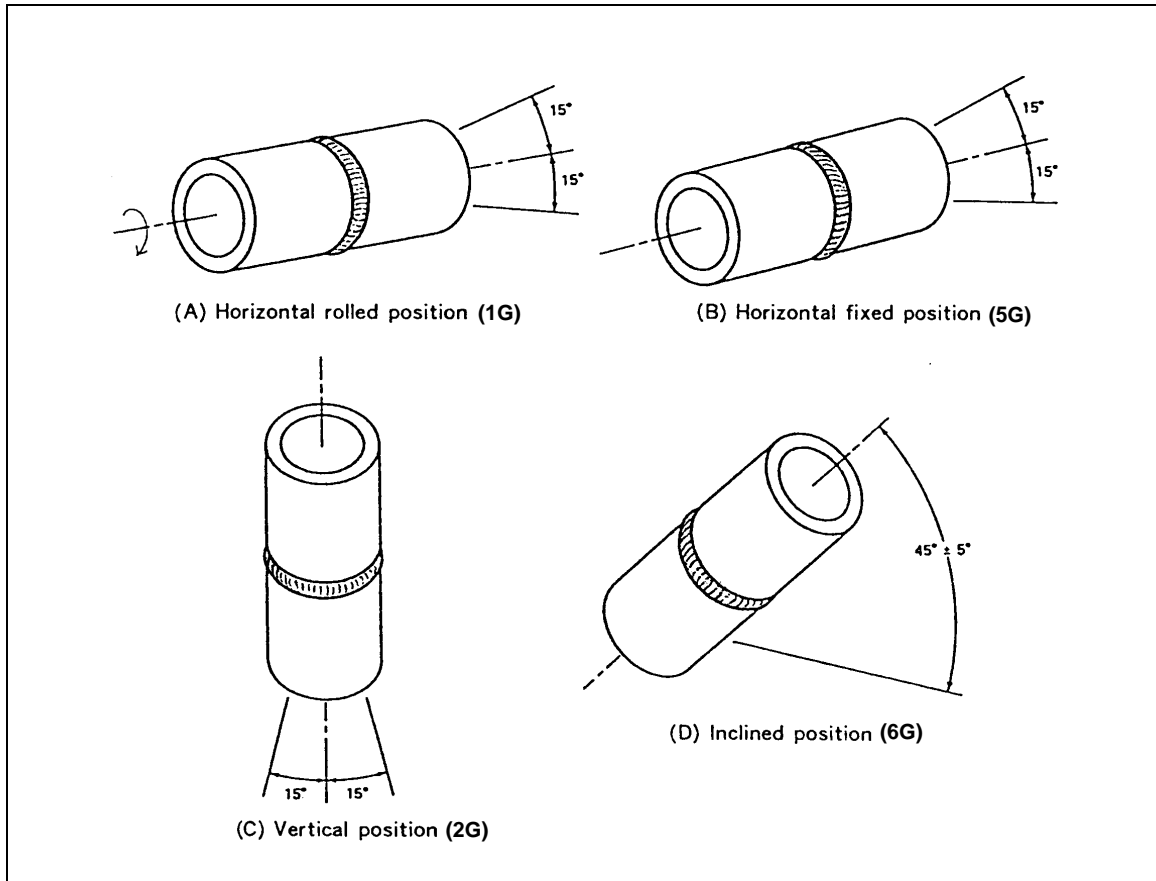

Fig. 4.12 — Welding positions for pipe welds

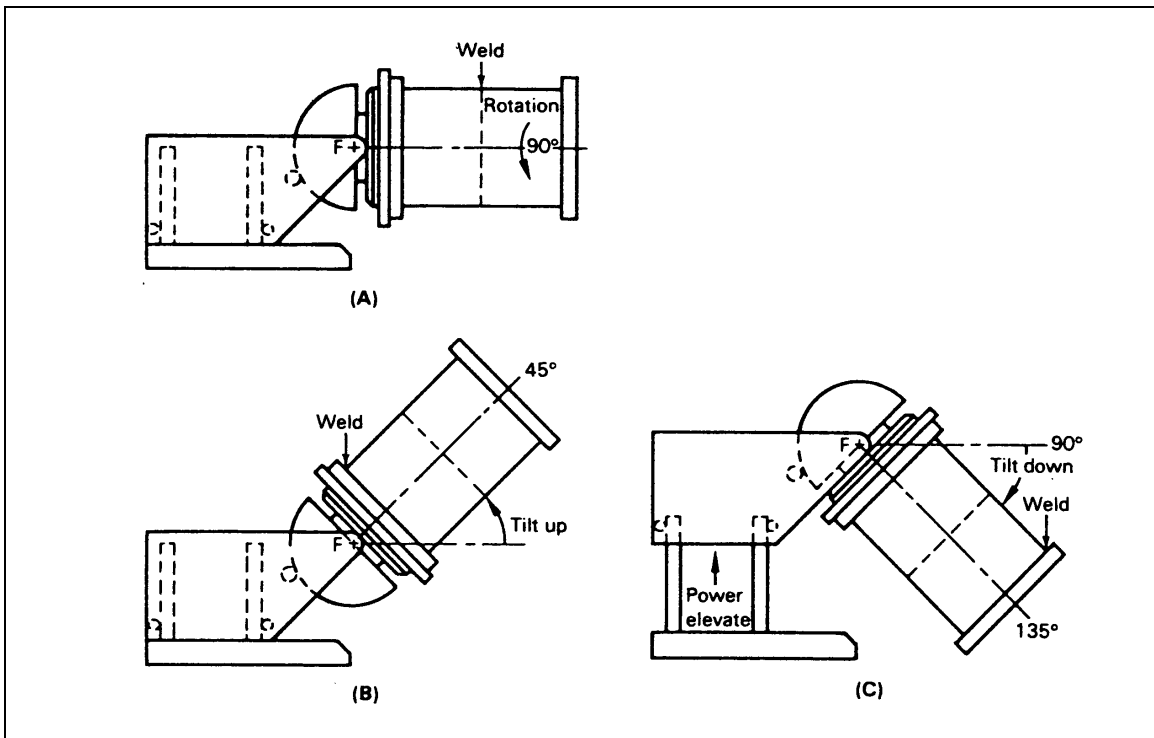

Fig. 4.13 — Welding a flanged cylinder with a powered elevation positioner  
(Source: AWS Welding Handbook)

#### 4.5 Welding conditions

In performing welding, it is important to use the optimum welding conditions particularly for welding current, voltage, and travel speed in consideration of the type of steel, plate thickness, joint configuration, welding position and quality requirement. Welding current in particular has a strong effect on the welding performance irrespective of the welding process. An optimum welding current for each welding position is determined by each manufacturer of welding consumables in consideration of three points: usability of the welding consumable, soundness of the weld metal, and the mechanical properties of the weld metal. Therefore, it is preferable to determine welding currents to be used taking into account the manufacturer recommendation. If either an excessively high or low current is used, even when no problem seems apparent, welding defects may occur and eventually repair work will be needed. Optimum current ranges for a covered electrode are shown in Fig. 4.14. As the diameter of an electrode increases, the optimum current becomes higher, and its range becomes wider.

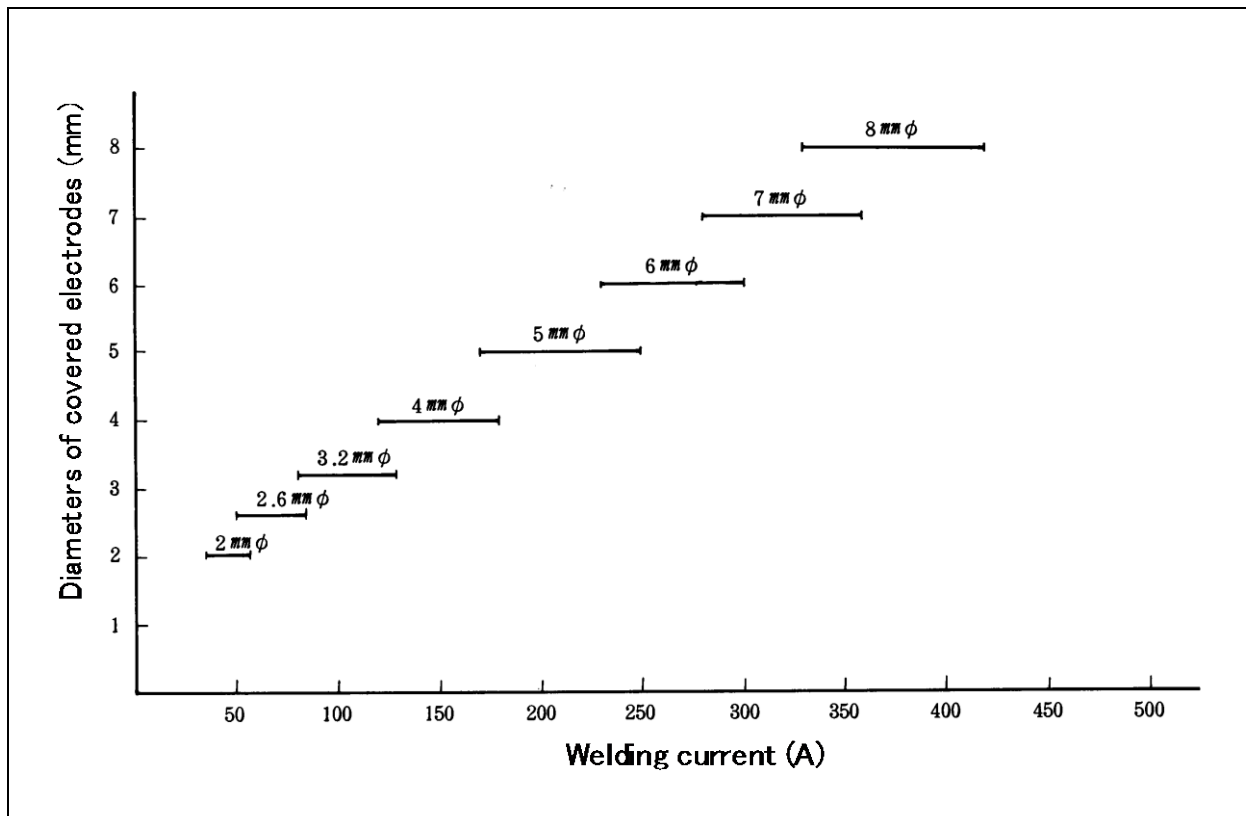

Fig. 4.14 — Optimum current ranges for an AWS E6019 electrode in flat position welding

#### 4.6 Manipulation techniques in welding

##### (1) Shielded metal arc welding

In the case of shielded metal arc welding, two methods are used to generate an arc, as shown in Fig. 4.15. With the method shown in Fig. 4.15(A), an arc can be generated by putting the tip of the electrode down lightly onto the surface of the base metal. In the method shown in Fig. 4.15 (B), strike the tip of the electrode across the surface of the base metal to generate an arc, as you would strike a match. In both of the methods, immediately after the arc is generated, move the electrode to the starting point of welding, maintaining an appropriate arc length.

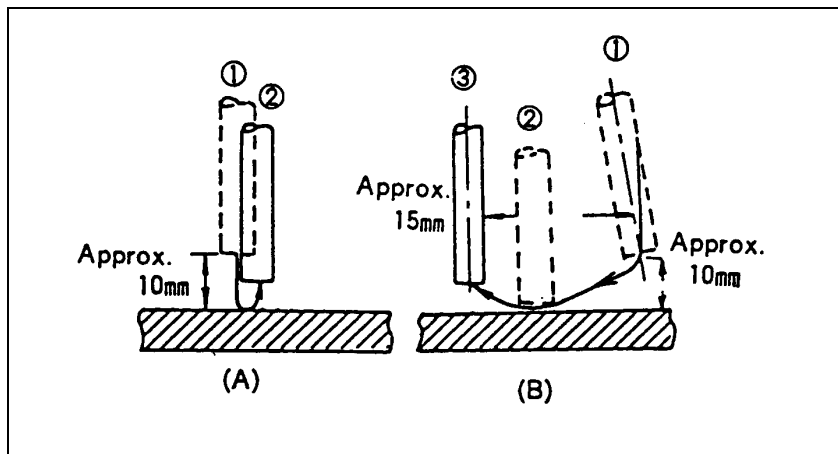

Fig. 4.15 — Arc striking methods

Beads can be straight or weaving, depending on how the electrode is manipulated. A straight bead can be obtained by moving the electrode in a straight line, keeping the electrode in an angle as shown in Fig. 4.16. Straight beads are best suited for sheet metals, root pass, and fillet welds.

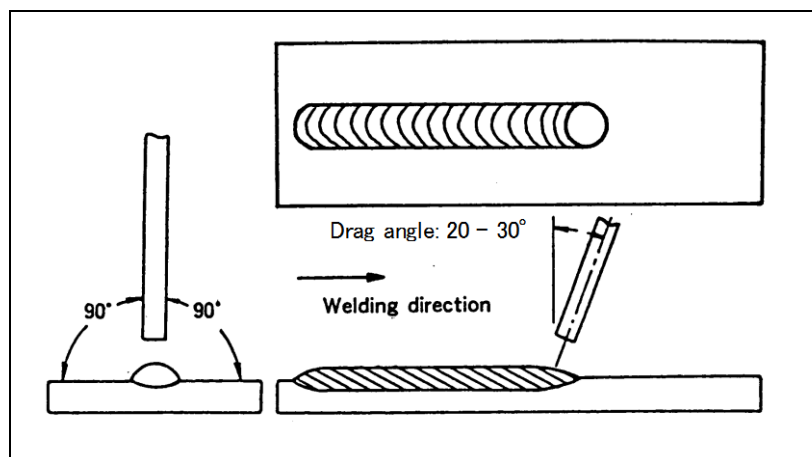

Fig. 4.16 — A straight bead in the flat position

In order to obtain a weld bead with a wide width, the weaving technique must be used: move the electrode from side to side as welding progresses as shown in Fig. 4.17. If the weaving technique is poor, the bead appearance will become uneven and cause welding defects such as undercut and slag inclusions. The width of weaving should be limited to three times the size of the electrode being used.

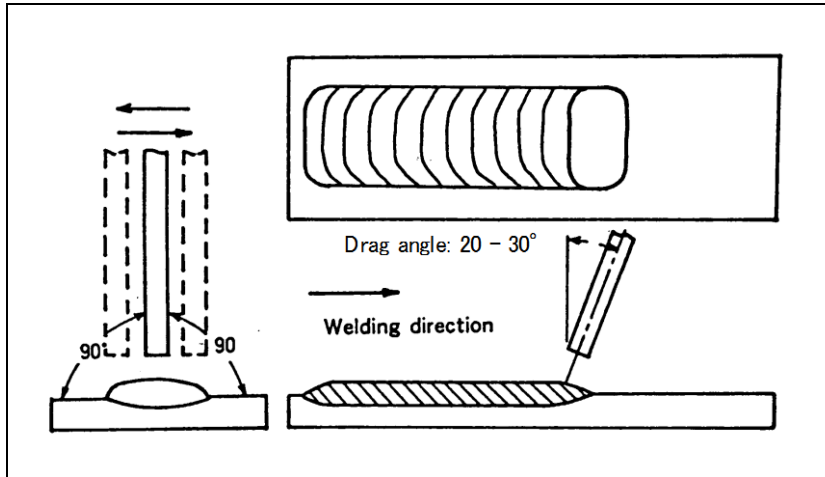

Fig. 4.17 — A weaving bead in the flat position

For depositing a long weld bead, the special technique is needed to join two or more beads. On making a bead junction, the electrode must be manipulated so that the height of the junction is even with both the preceding and succeeding beads as shown in Fig. 4.18. When the arc is extinguished at the end of a bead, the crater must be filled by using the crater treatment technique before cutting the arc. If not, the crater will be left concave containing crater cracks and blowholes. Crater treatment is performed by exposing the arc onto the crater to make it even with the weld bead surface.

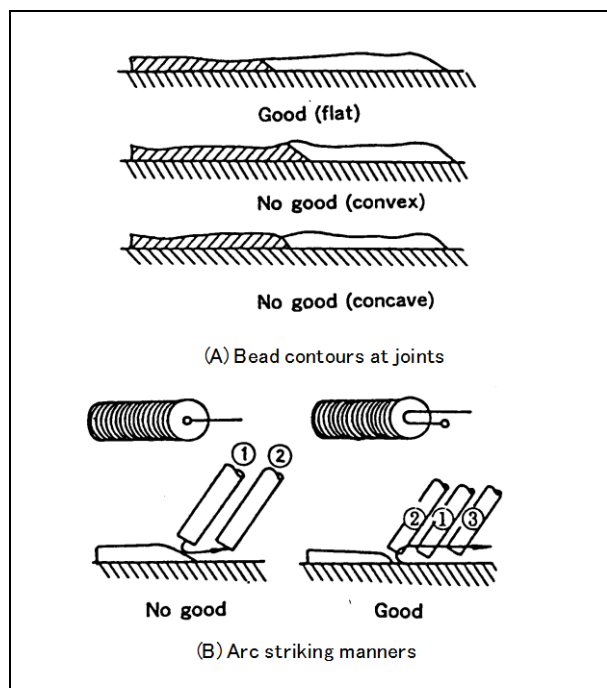
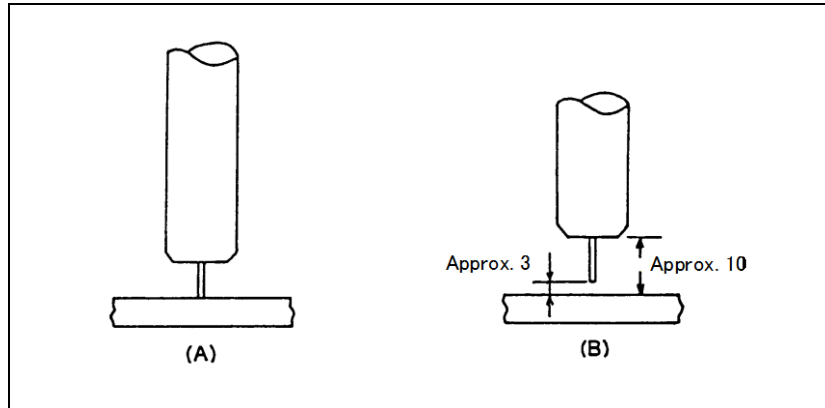

Fig. 4.18 — How to join weld beads

**(2) Gas shielded metal arc welding**

To perform gas shielded metal arc welding, set a welding wire, adjust the current, voltage and shielding gas flow rate; then keep the torch at the position where the tip of the wire can clearly be seen with an appropriate wire extension. To start an arc, as shown in Fig. 4.19 (A), place the tip of the wire at the target on the base metal, lift the torch upward a little to keep the wire tip at a standoff distance of about 3 mm as shown in Fig. 4.19 (B), and turn on the torch switch; consequently, the shielding gas, wire and electricity are fed sequentially to generate an arc.



**Fig. 4 19 — How to start an arc in gas shielded metal arc welding**

Since the gas shielded metal arc welding process generates a strong arc and less slag, either the forehand or backhand technique can be used as shown in Fig. 4.20. The forehand technique is used for horizontal fillet welding, cover-pass welding, and one-side welding, because the weld contour is rather flat. The backhand technique is better for the filling pass in the flat position, because the penetration is deeper.

The procedures for placing straight beads and weaving beads, the method of joining beads, and crater treatment are similar to those in shielded metal arc welding.

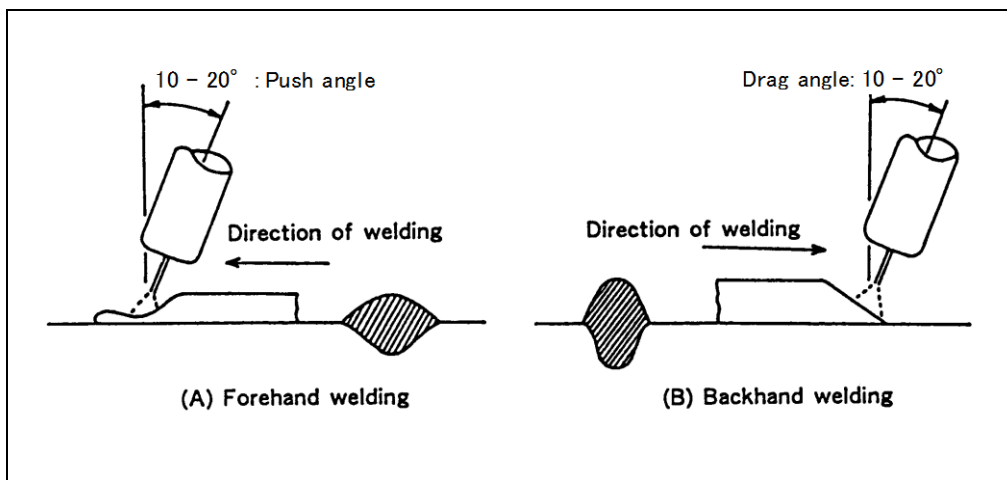

**Fig. 4.20 — A comparison between forehand welding and backhand welding**

#### 4.7 Residual stresses and distortion

Residual stresses are the stresses remaining in a structure as a result of thermal or mechanical treatment or both. The stresses arise in fusion welding primarily, because the melted material contracts on cooling from the solidus to room temperature. Residual stresses in a weldment have two major effects. First, they produce distortion, and second, they may cause premature failure. Distortion generates when the heated weld region contracts irregularly to cause shrinkage in one part of the weld and to exert eccentric forces across the weld section. The weldment strains elastically in response to these stresses, and these irregular strains result in the welding distortion. There are a number of types of distortion, as shown in Fig. 4.21; the magnitude of distortion depends on such factors as the type and size of base metal and filler metal and the welding sequence.

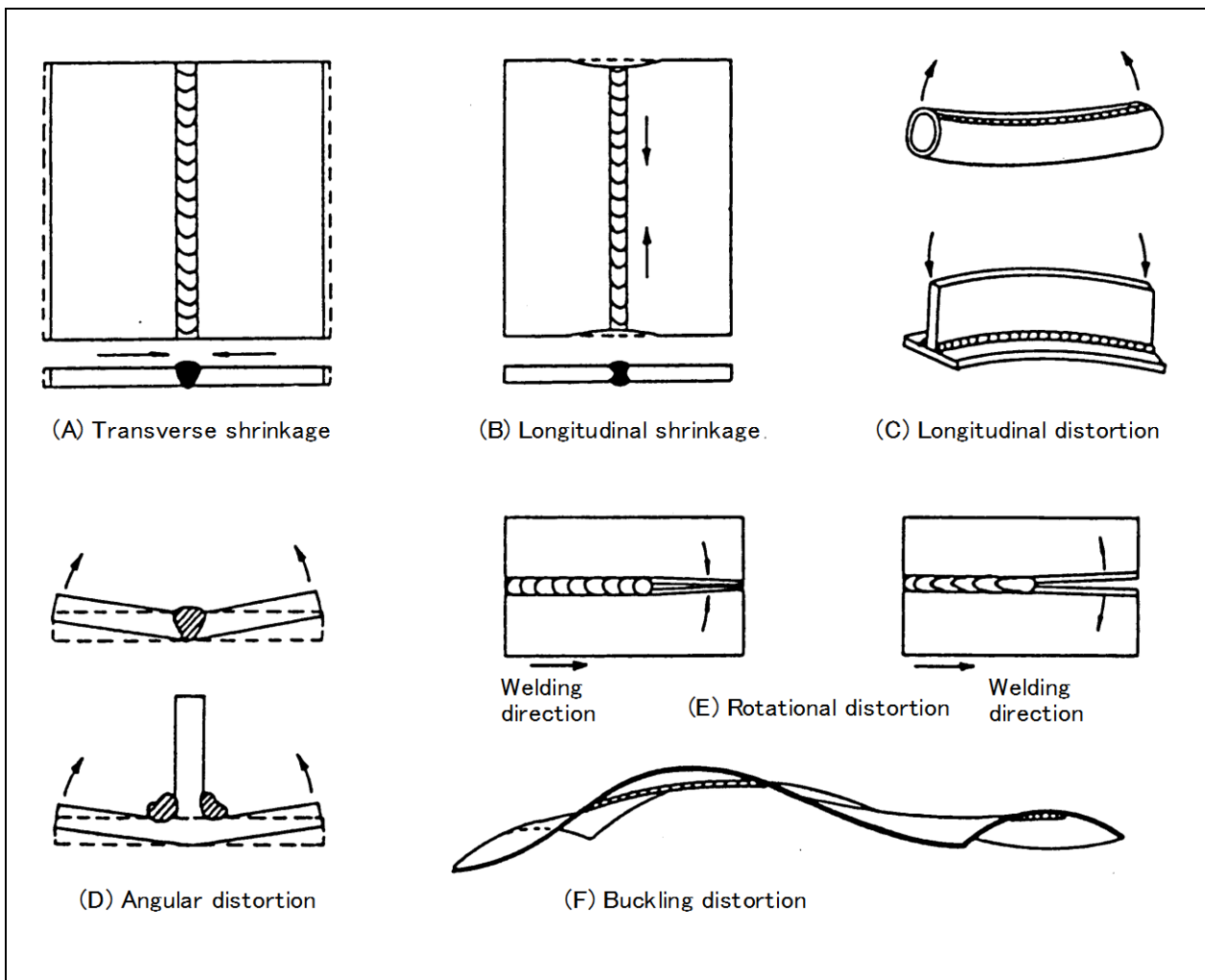

Fig. 4.21 — Variations in welding distortion

Fig. 4.22 shows various methods to prevent welding distortion by using welding jigs. In welding, the sequence of deposition and the order of welding should be determined to minimize welding distortion. The sequence of deposition should thoroughly be examined in order to minimize welding distortion. There are several sequences such as the forward, backward, symmetrical, and stepping stone methods as shown in Fig. 4.23.

In general, a structure to be welded has many welding lines. Consequently, if welding is done in the wrong order, the structure may distort, and cracks may occur in it. Therefore, the order of welding should thoroughly be examined beforehand, taking into account the welding contraction and expansion.

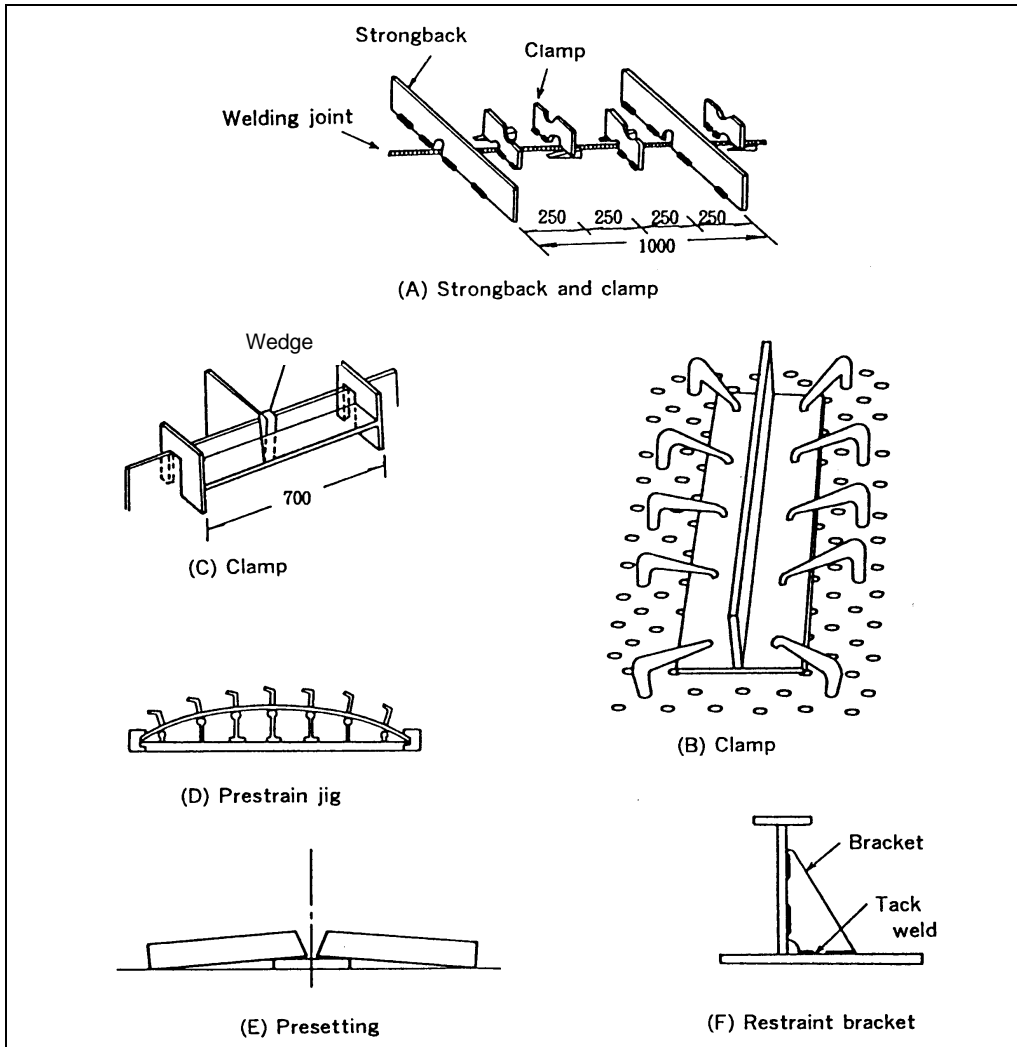

Fig. 4.22 — Some methods for preventing welding distortion

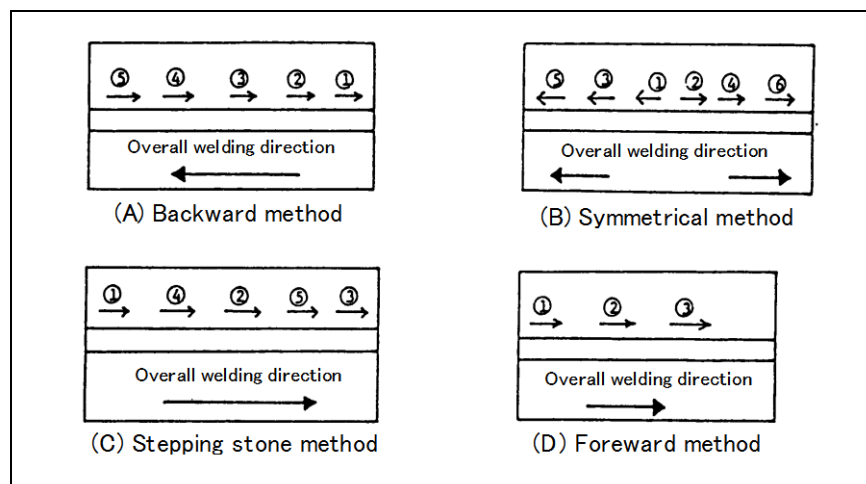

Fig. 4.23 — Deposition sequences



#### 4.8 Preheating

As the thickness of a base metal increases, the welded portion tends to cool faster. With an increase in the cooling rate of weld, the weld tends to increase its hardness, thereby decreasing its ductility. As a result, cold cracks such as root cracks, toe cracks and underbead cracks may occur in the heat-affected zone of the base metal, and longitudinal and transverse cracks may occur in the weld metal. The degree of the effect of the cooling rate on the weld hardening depends on the chemical composition of the base metal and weld metal. The degree of hardening of a particular type of metal is known as "hardenability." For example, mild steel has lower hardenability, but low alloy steel has higher hardenability. In general, lower hardenability leads to better weldability, and high hardenability leads to poor weldability.

In the welding of a base metal that has high hardenability, the base metal should be preheated to reduce the cooling rate of the weld, thereby preventing cold cracks. Preheating temperatures must be determined in consideration of several factors such as welding heat input, plate thickness, type of joint, the chemical composition of the base metal, the amount of hydrogen in the weld metal, and the degree of restraint of the welding joint. Table 4.2 shows general recommendations on the preheating temperatures for various metals. (In the case of copper alloys, preheating is applied not to prevent cracking, but to improve usability for better fusion and penetration)

**Table 4.2 — General recommendations on preheating temperatures for various types of metals**

Kind of metal	Preheating temperatures (°C)
HT 50	20 - 100
HT 60	60 - 100
HT 70	80 - 150
HT 80	100 - 180
Cast iron	150 - 300
0.5%Mo steel	100 - 200
Mn-Mo steel, Mn-Mo-Ni steel	150 - 250
0.5%Cr-0.5%Mo steel	150 - 250
1.25%Cr-0.5%Mo steel	150 - 300
2.25%Cr-1%Mo steel	200 - 350
5%Cr-0.5%Mo steel	250 - 350
9%Cr-1%Mo steel, 13%Cr-Mo steel	250 - 400
18%Cr steel	100 - 200
403 and 410 stainless steel	100 - 400
Bronze	150 - 200

Preheating can be performed with a gas torch using oxyacetylene, propane, or city gases. Induction coils, infrared ray heaters, and electric furnaces are also often used. The entire work should be preheated if possible; however, localized preheating can be applied, too. For measuring preheating temperatures, thermometers and the crayons that melt at specified temperatures can be used.

#### 4.9 Postweld heat treatment

Of the heat treatments to be carried out after welding is finished, stress relief heat treatment is important. Stress relief heat treatment is usually called SR or PWHT (Postweld Heat Treatment). In general, residual stresses may cause delayed cracking associated with diffusible hydrogen, premature failure associated with applied stresses, and higher susceptibility to corrosion cracking in fabricated structures. Therefore, in cases where residual stresses are required to remove, PWHT is applied. Residual stresses generated in welds can be removed by heating the weldment at an elevated temperature for a specified period of time, followed by gradual cooling. The heating temperature for PWHT varies according to the type of steel material and a specified standard. Table 4.3 shows some examples of heating temperatures and holding times for PWHT. As shown in the table, a thicker plate is required to be heated for longer hours and Cr- and Mo-bearing steel materials are required to be heated at higher temperatures in order to relieve residual stresses. For the latest information, refer to ASME B31.3:2012 (Process Piping). The entire weldment should be heat-treated if possible; however, localized heat treatment is often applied, too.

**Table 4.3 — Postweld heat treatment conditions for various types of steel (ANSI B31.3-90) (1)**

P No. (2)	Kind of steel	Heating temperatures (°C)	Holding time (h)
P1	Carbon steel	593 - 649 (3)	1 h for each 25.4 mm of plate thickness, but min. 1 h.
P3	C-0.5%Mo steel	593 - 718 (3)	
P4	1.25%Cr-0.5%Mo steel	704 - 746	1 h for each 25.4 mm of plate thickness, but min. 2 h.
P5	2.25%Cr-1%Mo steel	704 - 760	
	5%Cr-0.5%Mo steel		
	9%Cr-1%Mo steel		
P9A	2.5%Ni steel	593 - 635	1 h for each 50.8 mm of plate thickness, but min. 1 h.
P9B	3.5%Ni steel		
P11A	9%Ni steel	522 - 585	1 h for each 25.4 mm of plate thickness, but min. 1 h.

Note: (1) ANSI: American National Standards Institute, B31.3, "Chemical Plants and Petroleum Refinery Piping"

(2) Grouping of base metals for qualification per ASME sec. IX

(3) Substitute rules are specified in which lower temperatures can be used, provided longer holding times are applied.

#### 4.10 Welding defects and preventive measures

Because welding defects may impair the strength of a welded joint, they must be evaluated, in the light of the relevant specifications and standards, as to whether they must be repaired or they can be left. The causes of welding defects should thoroughly be investigated, and proper measures for preventing their recurrence should be taken. Fig 4.24 shows various welding defects which can occur, if welding procedures are not appropriate. Table 4.4 shows the causes of typical welding defects and preventive measures in shielded metal arc welding. Table 4.5 shows those in gas shielded metal arc welding. Fig. 4.25 shows some examples of actual welding defects.

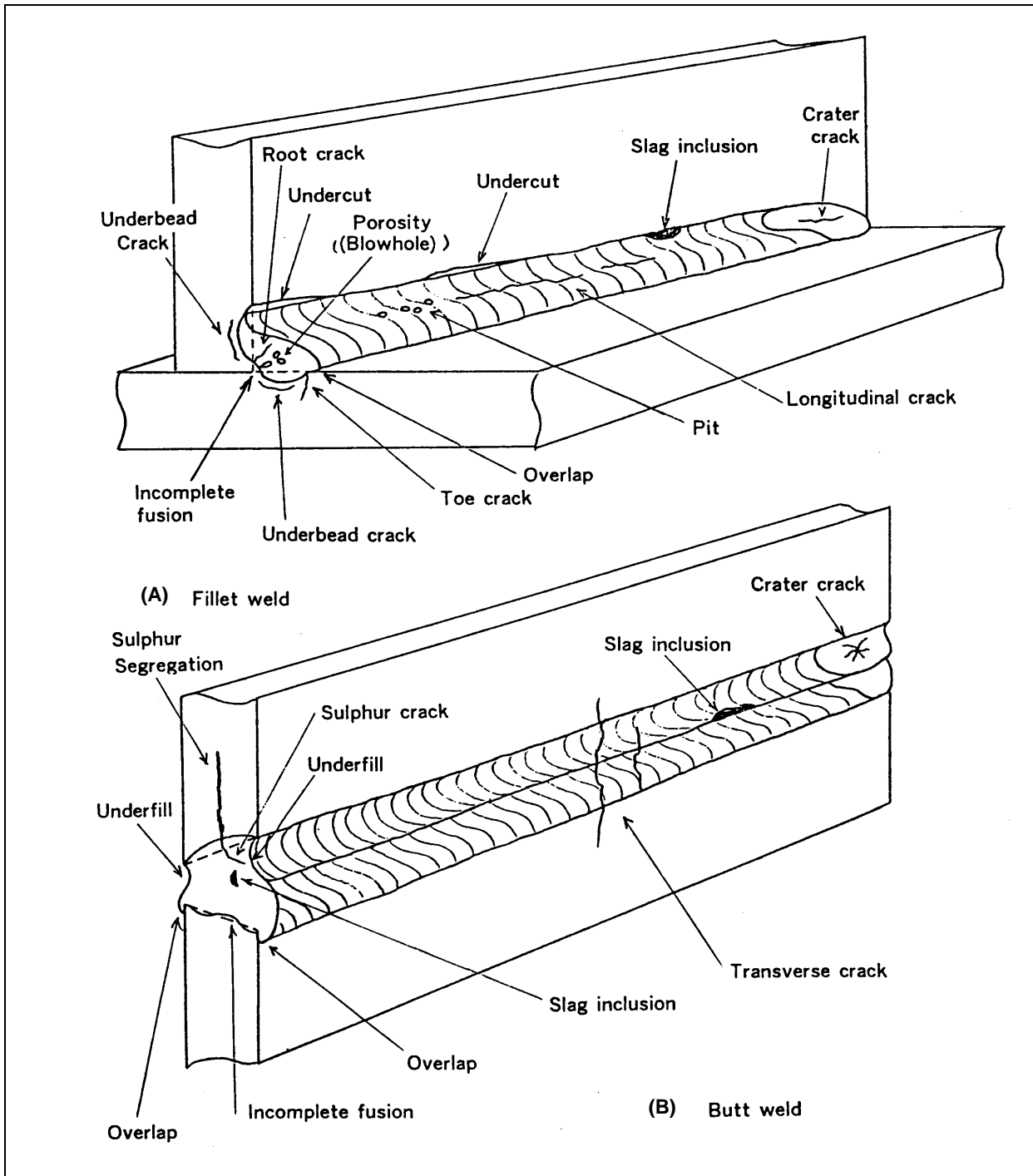

Fig. 4.24 — Various welding defects occurring in a but weld and a fillet weld

**Table 4.4 — Typical welding defects in shielded metal arc welding of carbon steel and low-alloy steel**

Kinds of welding defects	Causes of welding defects	Preventive measures
<b>Undercut</b>	<ol style="list-style-type: none"> <li>1. An arc blow that disturbs the arc direction in DC welding.</li> <li>2. Welding current is too high.</li> <li>3. Welding speed is too fast.</li> <li>4. Arc length is too long.</li> <li>5. Electrode drag angle is too large.</li> </ol>	<ol style="list-style-type: none"> <li>1. Place the grounding at the welding-start area of the base metal. Keep arc length shorter. Use run-on and run-off tabs.</li> <li>2. Use proper welding currents.</li> <li>3. Use proper welding speeds.</li> <li>4. Keep arc length as short as the electrode diameter.</li> <li>5. Keep electrode at a proper drag angle. (20-30 degrees)</li> </ol>
<b>Overlap</b>	<ol style="list-style-type: none"> <li>1. Welding current is too low.</li> <li>2. Welding speed is too slow.</li> <li>3. Arc length is too short.</li> <li>4. Electrode drag angle is too small.</li> </ol>	<ol style="list-style-type: none"> <li>1. Use proper welding currents.</li> <li>2. Use proper welding speeds.</li> <li>3. Keep arc length as short as the electrode diameter.</li> <li>4. Keep electrode at a proper drag angle. (20-30 degrees)</li> </ol>
<b>Porosity</b> including pits and blowholes	<ol style="list-style-type: none"> <li>1. Welding groove is contaminated with rust, oil, paint, or moisture.</li> <li>2. Electrode covering picks up a large amount of moisture.</li> </ol>	<ol style="list-style-type: none"> <li>1. Remove dirt in the welding groove by using a grinder, gas flame, or wire brush.</li> <li>2. Redry covered electrodes before use.</li> </ol>
<b>Slag inclusions</b>	<ol style="list-style-type: none"> <li>1. Weaving width is too much.</li> <li>2. Welding current is too low.</li> <li>3. Slag that remains in the preceding layers</li> <li>4. Welding groove is too narrow.</li> <li>5. Base metal is inclined downward to welding direction in the flat position.</li> </ol>	<ol style="list-style-type: none"> <li>1. Use proper weaving widths up to three times the electrode diameter.</li> <li>2. Use proper welding currents.</li> <li>3. Remove slag completely.</li> <li>4. Prepare the welding groove with a proper width.</li> <li>5. Keep base metal horizontally or use higher welding speeds, using a higher current.</li> </ol>
<b>Incomplete fusion</b>	<ol style="list-style-type: none"> <li>1. Welding current is too low.</li> <li>2. Welding speed is too fast.</li> <li>3. Arc voltage is too high.</li> <li>4. Welding groove is too narrow.</li> </ol>	<ol style="list-style-type: none"> <li>1. Use proper welding currents.</li> <li>2. Use proper welding speeds.</li> <li>3. Keep arc length as short as the electrode diameter.</li> <li>4. Prepare the welding groove with a proper width.</li> </ol>
<b>Cold cracks</b> (Mostly transverse cracks, toe cracks, root cracks, and underbead cracks, but possibly longitudinal cracks)	<ol style="list-style-type: none"> <li>1. Electrode covering that picks up a large amount of moisture.</li> <li>2. Cooling speed of weld is too fast.</li> </ol>	<ol style="list-style-type: none"> <li>1. Redry covered electrodes before use.</li> <li>2. Preheat base metal.</li> </ol>
<b>Hot cracks</b> (Mostly longitudinal cracks, crater cracks, and sulfur cracks, but possibly transverse cracks)	<ol style="list-style-type: none"> <li>1. Welding current is too high.</li> <li>2. Welding groove is too narrow.</li> </ol>	<ol style="list-style-type: none"> <li>1. Use proper welding currents.</li> <li>2. Prepare the welding groove with a proper width.</li> </ol>

**Table 4.5 — Typical welding defects in gas shielded metal arc welding of carbon steel and low-alloy steel**

Kinds of welding defects	Causes of welding defects	Preventive measures
<b>Undercut</b>	<ol style="list-style-type: none"> <li>1. An arc blow that disturbs the arc direction.</li> <li>2. Welding current is too high.</li> <li>3. Arc voltage is too high.</li> <li>4. Welding speed is too fast.</li> <li>5. The torch drag angle is too large.</li> </ol>	<ol style="list-style-type: none"> <li>1. Place the grounding at the welding-start area of the base metal. Keep arc length shorter. Use run-on and run-off tabs.</li> <li>2. Use proper welding currents.</li> <li>3. Use proper arc voltages.</li> <li>4. Use proper welding speeds.</li> <li>5. Keep the torch at a proper drag angle. (10-20 degrees)</li> </ol>
<b>Overlap</b>	<ol style="list-style-type: none"> <li>1. Arc voltage is too low.</li> <li>2. Welding speed is too low.</li> <li>3. The torch drag angle is too small.</li> </ol>	<ol style="list-style-type: none"> <li>1. Use proper arc voltages.</li> <li>2. Use proper welding speeds.</li> <li>3. Keep the torch at a proper drag angle. (10-20 degrees)</li> </ol>
<b>Porosity</b> including pits and blowholes	<ol style="list-style-type: none"> <li>1. Too little shielding gas is fed, because the gas regulator is frozen.</li> <li>2. Too little shielding gas is fed, because the nozzle is clogged with spatter.</li> <li>3. Shielding gas is contaminated with air, because the gas passage has a leak.</li> <li>4. Wind is too strong.</li> <li>5. Too little shielding gas is fed, because the nozzle diameter is too small.</li> <li>6. Shielding gas contains moisture.</li> <li>7. Grease, oil, moisture, and rust are adhered on the surfaces of the base metal, welding wire, and the passage of the welding wire.</li> <li>8. Arc is too long.</li> <li>9. Primer paint coated on the surfaces of the base metal.</li> </ol>	<ol style="list-style-type: none"> <li>1. Use a gas regulator with a built-in heater.</li> <li>2. Remove spatter clogged inside the nozzle. Use a spatter removal agent for the nozzle. Clean the orifice.</li> <li>3. Maintain the gas passage.</li> <li>4. Protect the welding area with a screen.</li> <li>5. Use a larger-size nozzle suited for the welding amperage.</li> <li>6. Use a shielding gas suitable for welding.</li> <li>7. Clean the welding groove, welding wire, and wire passage. If the wire has rust, discard the rusted part.</li> <li>8. Keep the arc at a proper length.</li> <li>9. Remove primer paint from the welding area. Use a suitable wire more resistible to the primer paint.</li> </ol>
<b>Incomplete fusion</b>	<ol style="list-style-type: none"> <li>1. Welding current is too low.</li> <li>2. Arc voltage is too low or too high.</li> <li>3. Welding speed is too fast or too slow.</li> <li>4. Welding groove is too narrow.</li> <li>5. The torch drag angle is too small.</li> </ol>	<ol style="list-style-type: none"> <li>1. Use proper welding currents.</li> <li>2. Use proper arc voltages.</li> <li>3. Use proper welding speeds.</li> <li>4. Prepare the welding groove with a proper width.</li> <li>5. Keep the torch at a proper drag angle. (10-20 degrees)</li> </ol>
<b>Cold cracks</b> (Mostly transverse cracks, toe cracks, root cracks, and underbead cracks, but possibly longitudinal cracks)	<ol style="list-style-type: none"> <li>1. Heat-affected zone is hardened because of fast cooling speed.</li> <li>2. Moisture contained in a shielding gas and on the surfaces of the groove.</li> </ol>	<ol style="list-style-type: none"> <li>1. Apply preheating.</li> <li>2. Use a shielding gas suitable for welding. Dry the surfaces of the groove.</li> </ol>
<b>Hot cracks</b> (Mostly longitudinal cracks, crater cracks, and sulfur cracks, but possibly transverse crack)	<ol style="list-style-type: none"> <li>1. Welding current is too high.</li> <li>2. Arc voltage is too low.</li> <li>3. Welding groove is too narrow.</li> </ol>	<ol style="list-style-type: none"> <li>1. Use proper welding currents.</li> <li>2. Use proper arc voltages.</li> <li>3. Prepare the welding groove with a proper width.</li> </ol>

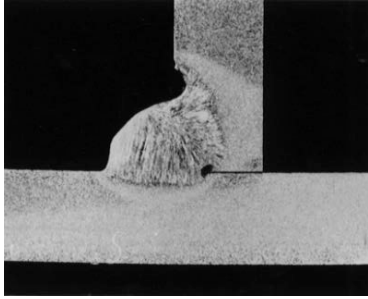

(A) Undercut

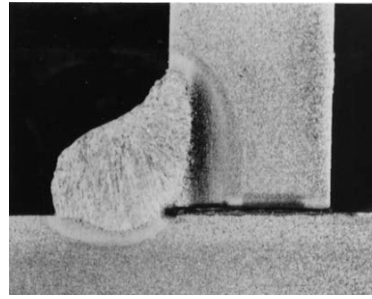

(B) Overlap

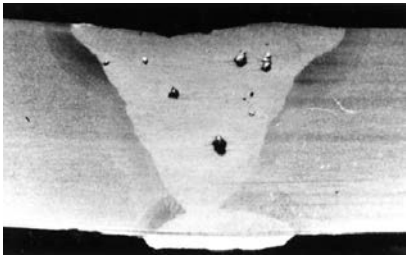

(C) Porosity

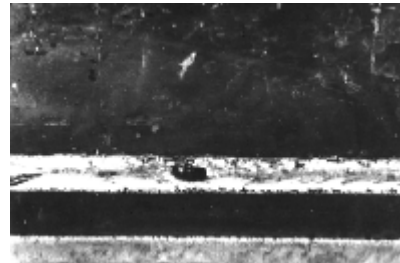

(D) Slag inclusion

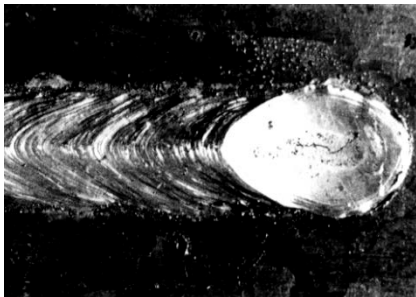

(E) Crater crack



(F) Root crack

**Fig. 4.25 — Examples of welding defects**

#### 4.11 Safety in welding

According to the Industrial Safety and Health Law of Japan, each workshop is required to establish the management system to secure the safety and health of workers and to promote the establishment of a comfortable work environment, thereby preventing labor accidents. Since welders work in a dangerous environment where high-temperature arc torches have to be handled, they face many potential dangers: electric shock, eye troubles, skin burns, metal fever, headache, fires, and explosions. Therefore, welders should be aware of accidents in welding and preventive measures for their own safety. Table 4.6 summarizes possible accidents in arc welding and preventive measures. Fig. 4.26 shows typical protective clothing.

**Table 4.6 — Possible accidents in arc welding and preventive measures**

Kinds of accidents	Causes	Preventive measures
•Electric shock: death or injury by electric shock	•High voltage: primary voltage: 200-220V secondary voltage: 65-95V	•Maintain the electric leads, terminals, holders, torches, and power sources insulated. •Keep work clothing dry. •Wear leather gloves.
•Burns: eye troubles and skin burns	•Strong visible rays, infrared rays, and ultraviolet rays generated from an arc. •Spatter	•Use goggles, shields with an appropriate shade glass, leather gloves, and other protective clothes.
•Headache and fever	•Fumes and gases	•Apply general ventilation or local ventilation. •Use respirators.
•Difficulty in breathing	•Oxygen shortage caused by a shielding gas (inert gas or CO <sub>2</sub> gas).	•Apply adequate ventilation to assure adequate oxygen for life support. •Use an air-supplied welding helmet.
•Fires	•Ignition of combustible substances by an arc or spatter.	•Remove combustible substances completely in advance.
•Explosions	•Ignition of explosive gases by an arc or spatter.	•Remove combustible and explosive gases completely in advance.



**Fig. 4.26 — Typical protective clothing in gas shielded metal arc welding**

## 4.12 Welding costs

### (1) Factors of cost estimation

The following are the basic factors for computing welding costs:

- a) The cost of labor
- b) The cost of welding consumables
- c) The cost of electric power
- d) The depreciation of welding equipment
- e) The cost of accompanied work (testing, heat treatment, grinder finishing, etc.)

Among these costs, a), b) and c) are major and are directly related to the total mass of welds. In order to calculate the major costs, the welding work time, the required quantity of welding consumables, and the required electric power must be calculated in advance, which depend on plate thickness, groove size, weld length, welding position, and welding amperage. By mechanizing the welding process, the welding speed can be increased so that the welding time can be shorter. However, the costs of mechanized welding equipment and for the work of setting up the equipment must be added.

The costs of labor and welding consumables are the governing factors that affect the total welding costs, which depend on the welding process. The following paragraphs provide fundamental data for calculating the costs of labor and welding consumables.

### (2) Welding work time

Welding work time can be obtained by the following formula:

$$Wt = [ C / \alpha ] \times 100$$

where Wt: Welding work time (min.)

C: Arc time (min.) = Deposited metal needed (g) / Deposition rate (g/min.)

$\alpha$  : Arc generation ratio (%): 5-40%

The arc time is the time needed for filling a welding groove with deposited metal. The deposition rate can vary according to the diameter of welding consumables, welding current, welding process, and wire extension in the case of gas shielded metal arc welding as shown in Fig. 4.27. The arc generation ratio is the ratio of the arc time to the welding work time that includes welding time, preparation time for welding, and time for postweld treatments. It is 30-40% in the case of exclusive welders and around 10% for welders who are in charge of assembling work in addition to performing welding.

Once you have calculated the welding work time (Wt), you can get the cost of labor by multiplying it with unit price of labor (@):

$$\text{Labor cost} = Wt \times @$$



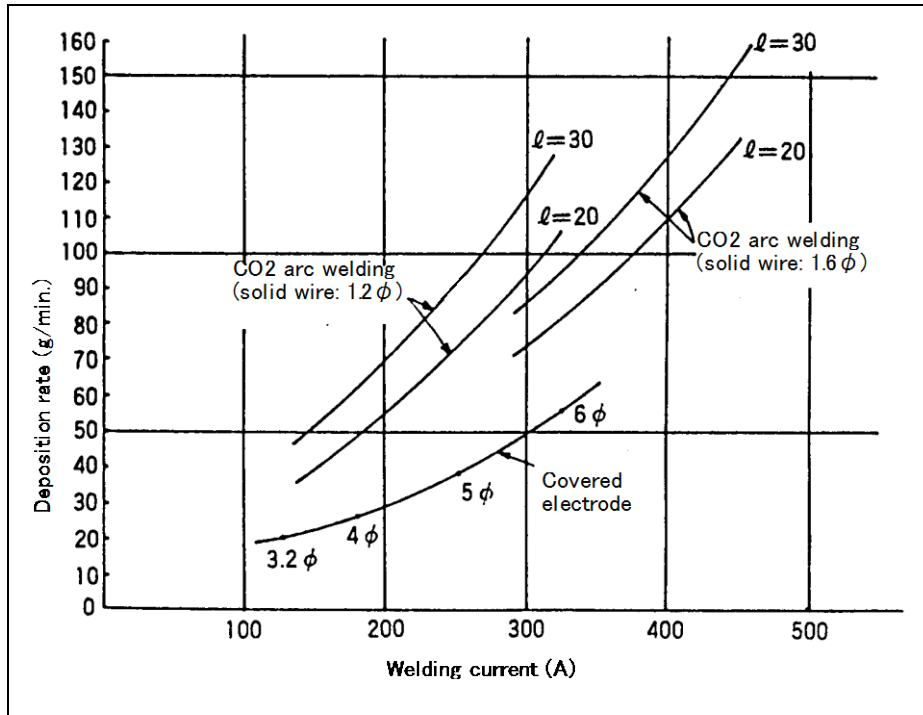

Fig. 4.27 — Deposition rates as a function of welding current (ℓ : wire extension)

**(3) Required quantity of welding consumables**

The required quantity of welding consumables to fill a given welding groove can be obtained by the following formula. The quantities of welding consumables needed for fillet welding and butt-welding are shown in Tables 4.7 and 4.8 respectively for quicker estimation.

$$Wd = [(A + B) \times L \times \rho / \eta] \times 100$$

- where Wd: Required quantity of welding consumables (g)
- A: Sectional area of a groove (cm<sup>2</sup>)
- B: Sectional area of reinforcement (cm<sup>2</sup>), A × 0.2
- L: Weld length (cm)
- ρ: Specific gravity of deposited metal, 7.85 g/cm<sup>3</sup> for carbon steel and low-alloy steel
- η: Deposition efficiency (%), 55% for covered electrodes, 95% for solid wires

Once you have calculated the required quantity of welding consumables (Wd), you can get the cost of welding consumables by multiplying it with the unit price of a welding consumable (@):

$$\text{Welding consumable cost} = Wd \times @$$

**Table 4.7 — Estimated quantity of welding consumables needed for fillet welding (1)**

Leg length (mm)	Shielded metal arc welding	CO <sub>2</sub> arc welding
	Quantity of covered electrodes needed for 1-m length of weld (kg/m)	Quantity of solid wires needed for 1-m length of weld (kg/m)
3	0.077	0.044
4	0.137	0.079
5	0.214	0.124
6	0.308	0.179
7	0.419	0.243
8	0.548	0.317
9	0.693	0.402
10	0.856	0.496
11	1.036	0.600
12	1.232	0.714

Note: (1) Computed by using the following simplified formulas for fillet welding provided the reinforcement areas and leg lengths are determined as shown in the following figures.

For covered electrodes:

$$W_b = 856 \ell^2 \cdot 10^{-5} \text{ (kg/m)}$$

For solid wires:

$$W_b = 496 \ell^2 \cdot 10^{-5} \text{ (kg/m)}$$

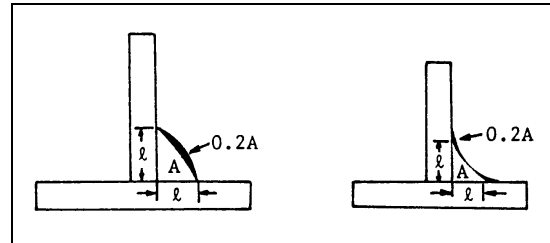

**Table 4.8 — Estimated quantity of welding consumables needed for butt welding (1)**

Groove sizes		Quantity of covered electrodes needed for 1-m length of weld in shielded metal arc welding, (kg/m)					Quantity of solid wires needed for 1-m length of weld in CO <sub>2</sub> arc welding, (kg/m)				
θ (deg)	c (mm)	0	1	2	3	4	0	1	2	3	4
	b (mm)										
60	0	1.18	1.00	0.82	0.67	0.53	0.68	0.58	0.47	0.37	0.30
	1.0	1.36	1.16	0.98	0.84	0.62	0.78	0.67	0.57	0.48	0.40
	1.5	1.44	1.25	1.07	0.93	0.78	0.83	0.73	0.62	0.53	0.45
	2.0	1.53	1.33	1.16	1.00	0.87	0.88	0.77	0.67	0.58	0.50
	2.5	1.60	1.42	1.24	1.09	0.95	0.93	0.82	0.72	0.63	0.55
	3.0	1.69	1.51	1.33	1.18	1.04	0.98	0.87	0.77	0.68	0.60
	4.0	1.85	1.67	1.51	1.34	1.20	1.07	0.97	0.87	0.78	0.69
70	0	1.44	1.20	1.00	0.80	0.64	0.83	0.69	0.58	0.46	0.37
	1.0	1.60	1.36	1.16	0.98	0.80	0.93	0.79	0.67	0.57	0.46
	1.5	1.69	1.45	1.25	1.05	0.89	1.02	0.89	0.77	0.66	0.57
	2.0	1.76	1.55	1.33	1.15	0.98	1.07	0.95	0.82	0.72	0.61
	2.5	1.85	1.64	1.42	1.24	1.05	1.13	0.99	0.87	0.76	0.66
	3.0	1.95	1.71	1.51	1.31	1.15	1.22	1.09	0.97	0.86	0.76
	4.0	2.11	1.89	1.67	1.49	1.31	1.52	1.39	1.25	1.16	1.06

Note: (1) The groove configuration is as shown below.

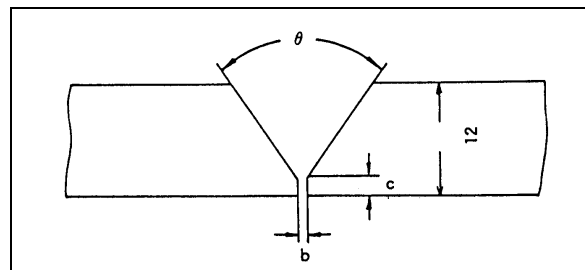

## 5. Welding Metallurgy and Weldability

Welding can be described as metal production or metallurgy in which melting, refining and casting are performed in an extremely short time. In arc welding, the base metal is locally melted together with a welding consumable by the arc heat and solidified, creating the weld metal. The weldability of a base metal and a welding consumable basically govern the quality of welded joints. Therefore, in welding engineering, the knowledge of welding metallurgy and weldability is very important.

### 5.1 Types and features of base metals

Most metals used commonly can be welded successfully, provided proper welding procedures are used. These metals can be categorized into ferrous and non-ferrous; each of them can be further classified into various types according to chemical composition and mechanical properties. Fig. 5.1 outlines a classification of metals used in welding. The majority of metals used for general applications are carbon steel, and they can be classified as follows by the amount of carbon: (1) Low-carbon steel (less than 0.30%C), (2) Medium-carbon steel (0.30-0.50%C), and (3) High-carbon steel (0.50-2.0%C). Because the hardness of steel materials increases as the amount of carbon increases, low-carbon steel is often referred to as mild steel, medium-carbon steel as semi-hard steel, and high-carbon steel as hard steel. Table 5.1 shows a classification of carbon steel materials by hardness.

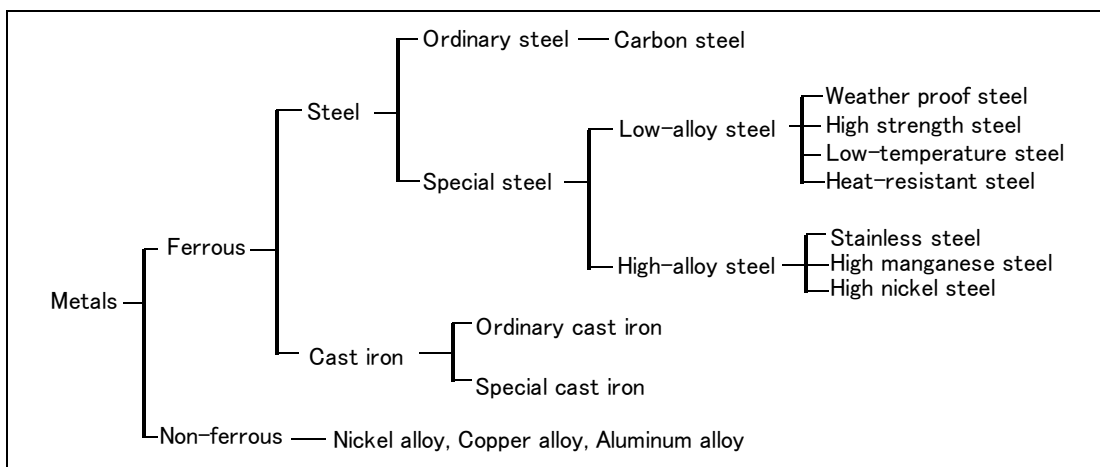

Fig. 5.1 — Classification of metals

Table 5.1 — Classification of carbon steel by hardness

Classification	Carbon content (%)	Yield strength (N/mm <sup>2</sup> )	Tensile strength (N/mm <sup>2</sup> )	Elongation (%)	Hardness (HB)	Usage
Ultra-dead mild steel	0.08 max.	176-274	314-353	30-40	95-100	Sheet metals
Dead mild steel	0.08-0.12	196-284	353-412	30-40	80-120	Electrodes, Wires
Mild steel	0.12-0.20	216-294	372-470	24-36	100-130	Structural materials
Semi-mild steel	0.20-0.30	235-353	431-539	22-32	112-145	
Semi-hard steel	0.30-0.40	294-392	490-588	17-30	140-170	Machinery, Tools, Rails, Springs, Piano wires, Dies
Hard steel	0.40-0.50	333-451	568-686	14-26	160-200	
Ultra-hard steel	0.50-0.80	353-461	637-980	11-20	180-235	

Carbon steel is an iron-carbon alloy, and it usually contains silicon (Si) and manganese (Mn) by which its mechanical properties can be considerably improved. They also contain such impurities as phosphorous (P) and sulfur (S). These impurities adversely affect the toughness and weldability of steel materials. Carbon has a remarkable influence upon the weldability and mechanical properties of steel materials. Fig. 5.2 shows the effects of carbon content on the mechanical properties of carbon steel.

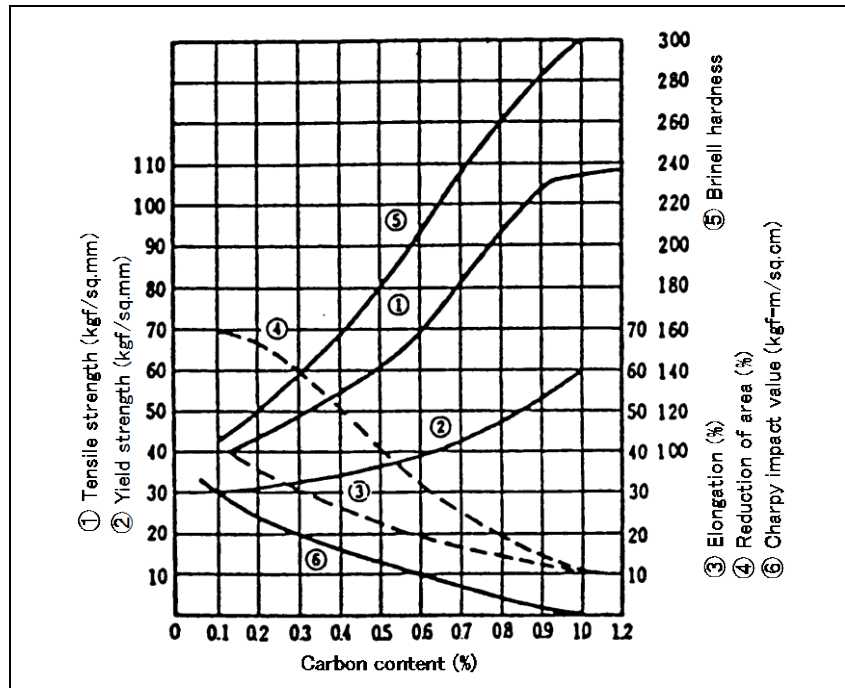

Fig. 5.2 — Relationship between carbon content and mechanical properties of carbon steel

### 5.2 Metallurgical features of welds

The maximum temperature of a welding arc is as high as 5,000 to 6,000°C. The base metal near the arc is heated and melted by this heat in welding. The weld is rapidly heated to high temperatures and quickly cooled after removal of the arc. Fig. 5.3 shows a weld, which consists of the weld metal made from deposited metal and the melted part of the base metal, the heat-affected zone of the base metal subjected to the arc heat cycle, and the unaffected (by the arc heat) zone of the base metal.

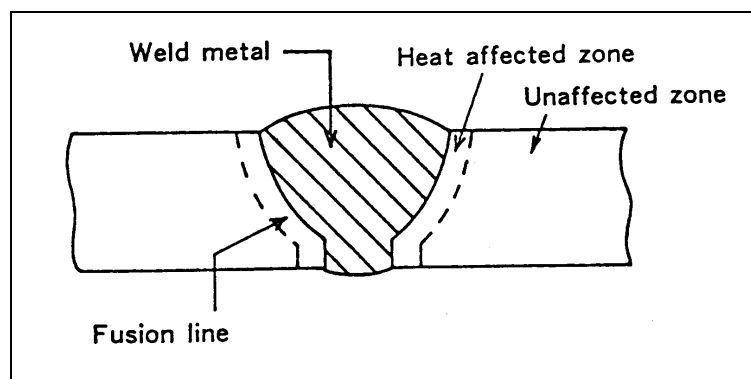
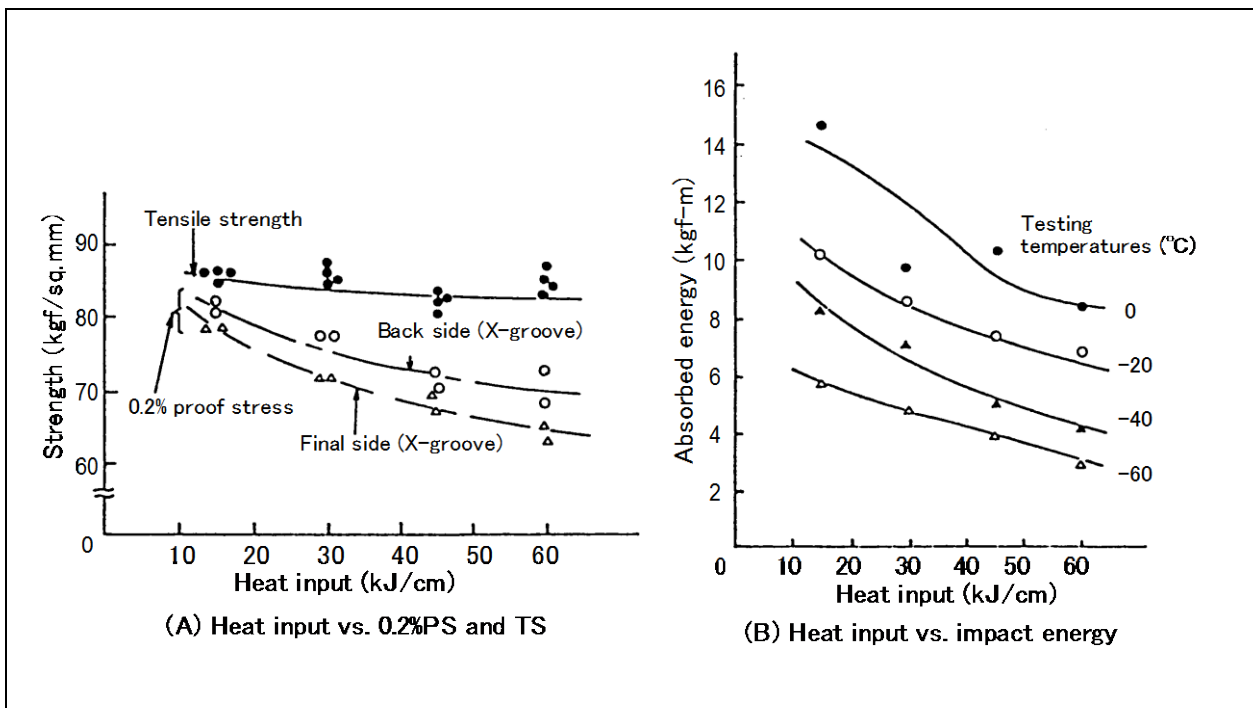

Fig. 5.3 — A macro-section of weld

### 5.2.1 Features of weld metal

A filler metal or a welding consumable can be almost uniformly fused together with part of the base metal by the arc heat to form a molten weld metal in the welding groove; as the molten weld metal solidifies, it creates a columnar structure. This process of solidification is similar to that of casting in steel production. In the solidification process of the molten weld metal, columnar crystals develop from the fusion lines, or the base metal to molten weld metal interfaces, toward the central part of the molten weld metal due to a temperature gradient inside the molten weld metal.

The quality of weld metal varies depending upon heat input, heat cycle, chemical composition of deposited metal and base metal, and the ratio of weld metal dilution by base metal. Fig. 5.4 shows the relationship between heat input and the mechanical properties of the weld metal of high strength steel. This figure clearly shows that tensile strength and impact strength decrease as the heat input increases.



**Fig. 5.4 — Relationship between heat input and mechanical properties of high strength weld metal in shielded metal arc welding**

The ratio of weld metal dilution by base metal can vary from 10 to 20% in shielded metal arc welding. The dilution ratio increases to 50-60% in one-sided submerged arc welding. Thus, the chemical composition of the base metal affects the quality of the weld metal to a greater extent in submerged arc welding. In cases where there is a remarkable difference between the chemical composition of the base metal and that of the deposited metal, as observed in welding a dissimilar-metal joint, it should be noted that the quality of the weld metal can change remarkably depending on the depth of penetration or dilution. Fig. 5.5 shows how to determine the dilution ratios.

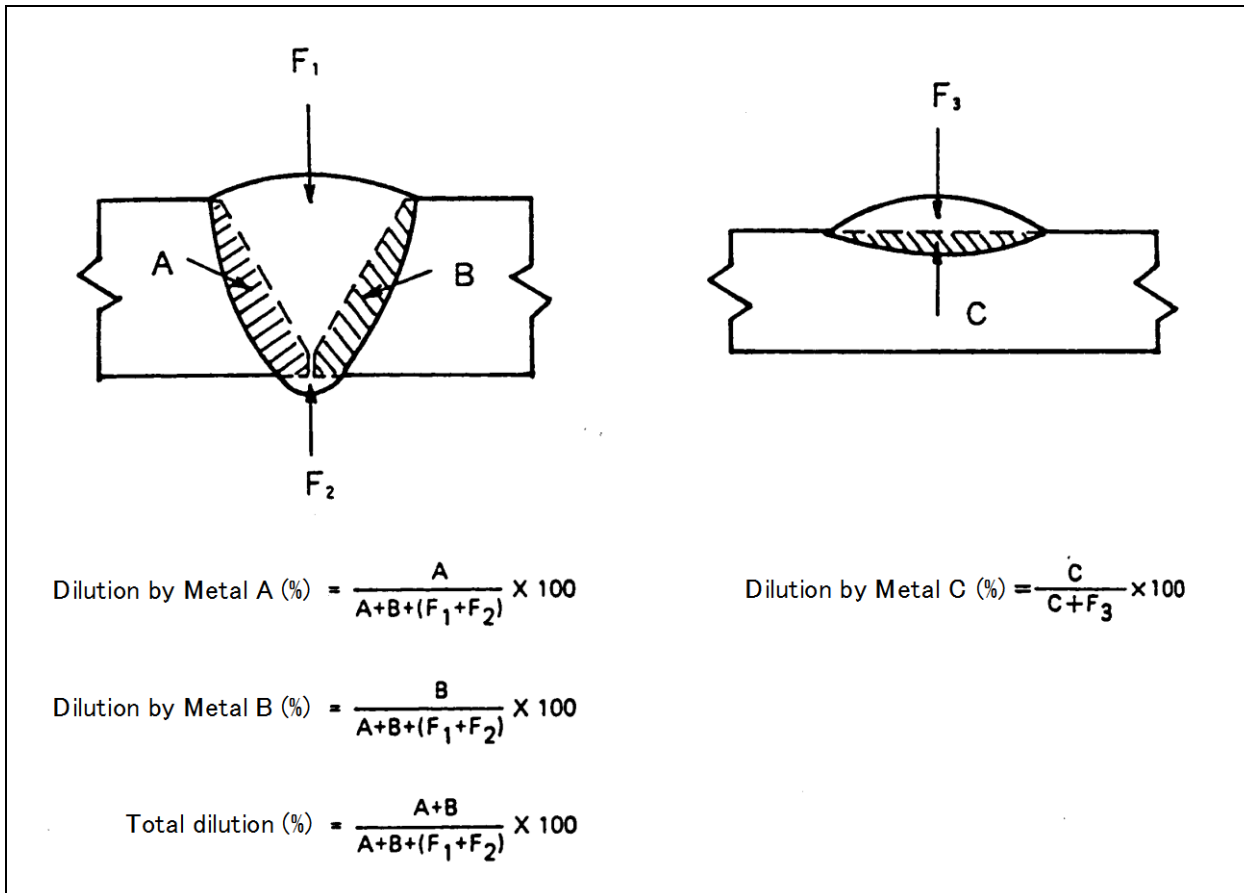

Fig. 5.5 — Determination of the dilution ratios of welds

### 5.2.2 Features of the heat-affected zone

The heat-affected zone (HAZ) is the area developed in the base metal adjacent to the weld metal by heating at high temperatures near the melting point of the base metal, followed by cooling to room temperature in a very short time. The cooling rate affects the hardness, crystal grain size and mechanical properties of the heat-affected zone. The cooling rate decreases with increases in the heat input and the base metal temperature. The cooling rate increases as the thickness of the base metal increases. The maximum temperature and the cooling rate of the heat-affected zone vary depending on the location in the heat-affected zone. Due to such thermal variations, the metallurgical structure varies within the heat-affected zone of a base metal. Table 5.2 shows the categories of the metallurgical structures of a mild steel weld. Fig. 5.6 shows the microstructures of a 0.35%C-steel weld.

**Table 5.2 — Structural categories of a mild steel weld**

Structural category	Heating temperature range (°C)	Remarks
Weld metal	More than 1500	Dendrite structure solidified from the molten state.
Fusion zone	More than 1450	Base metal is partially melted and partially overheated without melting, resulting in extreme coarse grains and hardened structure.
Coarse grain zone	1450-1250	Coarse and hardened structure.
Intermediate grain zone	1250-1100	Intermediate structure between coarse grain and fine grain zones.
Fine grain zone	1100-900	Fine grain structure provided by the $A_{C3}$ transformation.
Granular pearlite zone	900-750	Granular pearlite structure provided by heating at temperatures between $A_{C1}$ and $A_{C3}$ .
Brittle zone	750-200	Embrittled structure.
Unaffected zone of base metal	200-Room temperature	As-manufactured structure.

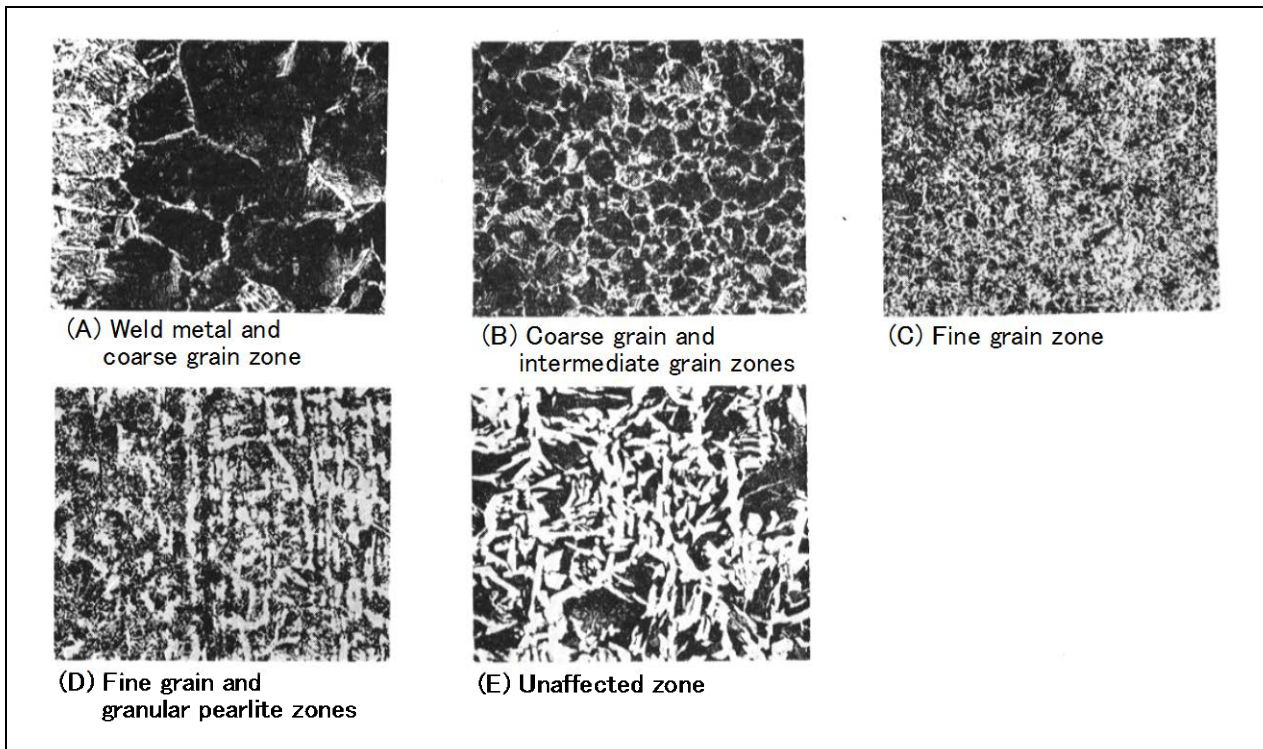

**Fig. 5.6 — Microstructures of a 0.35% C steel weld**

The heat-affected zone of a carbon or low alloy steel weld is hardened in general as a result of rapid cooling in welding. Fig. 5.7 shows hardness distributions of a weld. Because of high cooling rate, considerable hardening occurs particularly at the portion adjacent to the fusion line in the heat-affected zone.

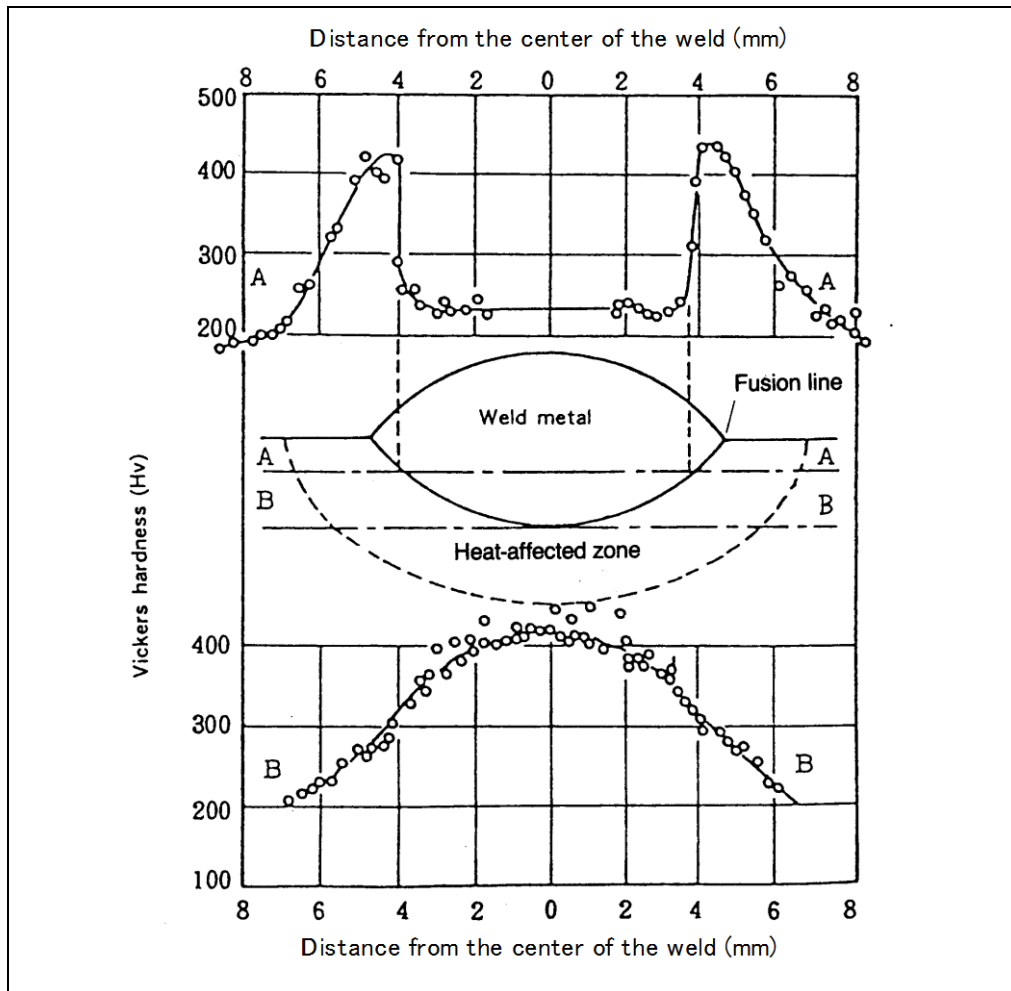

**Fig. 5.7 — Hardness distributions of a 50HT steel weld**  
 (Base metal: 20-mm thick plate; 0.20%C, 1.38%Mn, 0.2%Si; 170A, 25V, 15 cm/min.)

Hardening in the heat-affected zone may cause cracking due to decreased ductility. Therefore, it is desirable to limit the hardness to a minimum level to ensure better weldability. The maximum hardness of heat-affected zone is governed by the alloying elements contained in the base metal and the cooling rate in welding. Though the maximum hardness is governed mainly by the carbon content in a base metal, other alloying elements also affect the hardness at a low or high degree. The carbon equivalent can be obtained by totaling the carbon content and the degrees of influence of other alloying elements in comparison with that of carbon. The following formula is commonly used in Japan for evaluating the hardening of welds:

$$C_{eq} = C + \frac{1}{6}Mn + \frac{1}{24}Si + \frac{1}{40}Ni + \frac{1}{5}Cr + \frac{1}{4}Mo$$

where  $C_{eq}$ : Carbon equivalent,

C, Mn, Si, Ni, Cr, Mo: Percentage of each element contained in steel



The relationship between the maximum hardness and the carbon equivalent of a 20-mm thick plate of mild steel and high strength steel is shown in Fig. 5.8. Using the carbon equivalent the maximum hardness can be estimated by the following formula:

$$H_v (\text{max}) = (666 \times C_{eq} + 40) \pm 40$$

where  $H_v$ : Vickers hardness

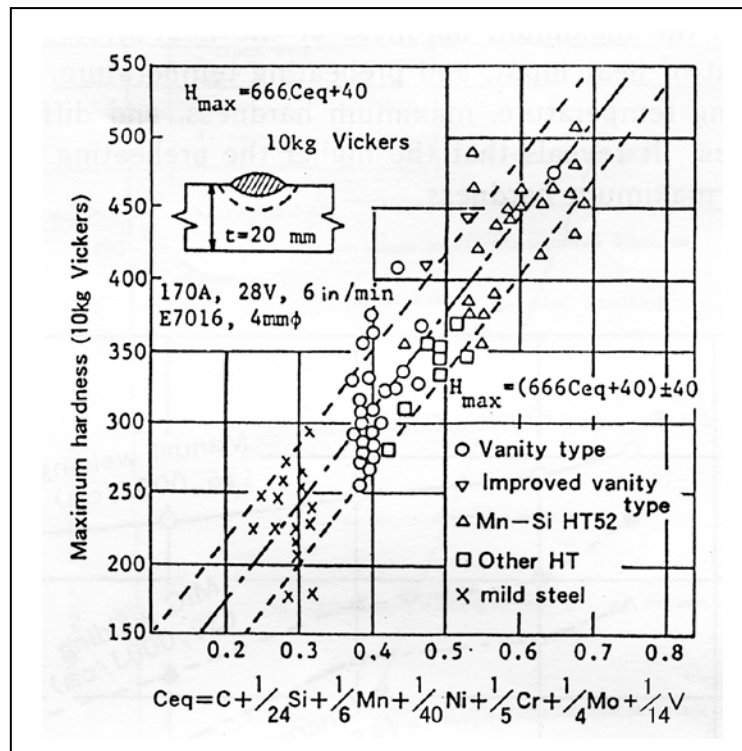

Fig. 5.8 — Relationship between maximum hardness of welds and carbon equivalent of mild steel and high strength steel

As the carbon equivalent of the base metal increases the maximum hardness of the weld becomes higher and the weld becomes more susceptible to underbead cracking as shown in Fig. 5.9.

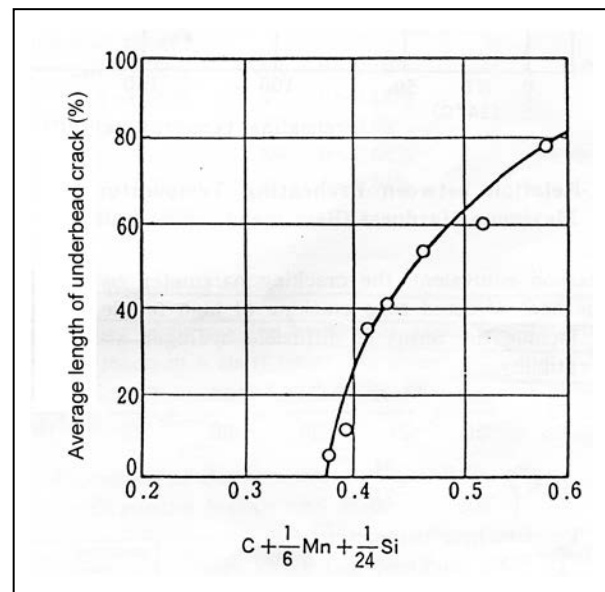

Fig. 5.9 — Relationship between carbon equivalent and underbead cracking under the following testing conditions:

Base metal: C-Mn steel, 38-mm thick  
 Electrode: E6010, 3.2mm  $\phi$   
 Welding conditions: 100A, 25V, 25cm/min  
 Bead length: 32mm

The maximum hardness of the heat-affected zone is influenced by plate thickness, heat input, and preheating temperature, besides the carbon equivalent. Fig. 5.10 shows the relationship between preheating temperature and maximum hardness with different amounts of heat input by different welding processes. Clearly, the higher the preheating temperature and the heat input, the lower the maximum hardness.

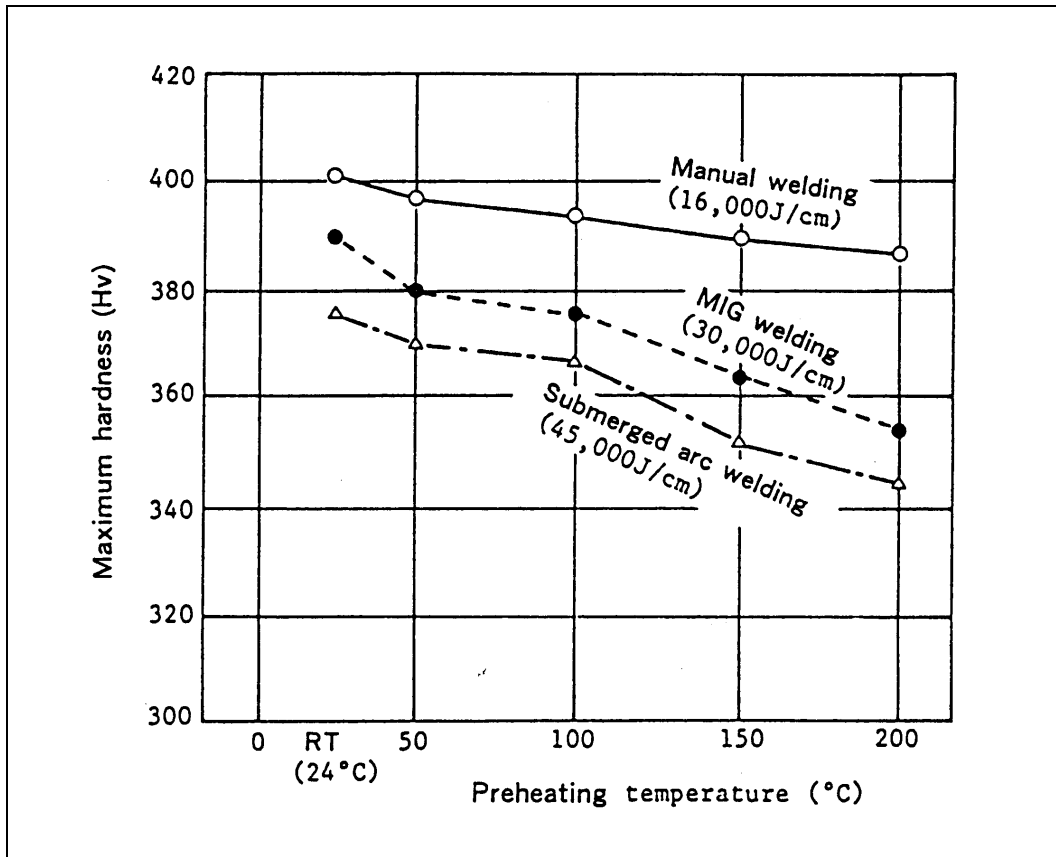

Fig. 5.10 — Relationship between preheating temperature and maximum hardness of welds with different amounts of heat input by different welding processes (Base metal: carbon steel)

## 6. Test and Inspection of Weldment

A welded structure must be safe and reliable. It is often said that the integrity of a weldment can be achieved only when welding design, welding fabrication, material, and welding skill are all appropriate. A welded structure can be suited for an intended application only when the operational conditions of the application are taken into account in the welding design and fabrication. But such care does not necessarily guarantee the quality of the welded structure, because welding always brings about some metallurgical changes, distortion, and stresses. Accordingly, testing and inspection are needed in order to confirm that the weldment meets the requirements.

In testing, a weldment is examined according to a specified procedure, and the test results are presented in a certain written format. In inspection, the test results are checked whether they satisfy the criteria of the specification, and they have to be judged by an inspector. Various tests and inspections are carried out according to the specification required, considering the type of structure and the environmental factors such as operational temperature, corrosion and mechanical wear involved in the operation. Inspection should be conducted throughout the period of time during the welding fabrication. Table 6.1 shows various inspection items that should be inspected at every stage of the welding fabrication.

**Table 6.1 — Inspection items and contents for welding fabrication**

Inspection stages	Contents of inspection	
Before welding	(1) Welding equipment	Confirm the perfection of welding power sources, their accessories, jigs, etc.
	(2) Welding consumables	Confirm the size, chemical composition, mechanical properties, usability, and weldability of the welding consumables to be used.
	(3) Base metals	Confirm the chemical composition, mechanical properties, and heat treatment of the base metals to be used.
	(4) Welding joints	Confirm the groove angle, root opening, and surface condition of the welding joints. Confirm the perfection of tack weld beads.
	(5) Welding and related operations	Confirm the required conditions of welding, preheating, post-heating, and postweld heat treatment.
	(6) Welder's and welding operator's skill	Confirm the qualification status and experience of the welders and welding operators to be assigned.
During welding	(1) Welding defects and distortion	Check bead appearance layer by layer, and check the distortion occurred in the weldment.
	(2) Welding conditions	Check welding currents, arc voltages, pass sequences, welding positions, and preheat and interpass temperatures.
After welding	(1) Confirm the perfection of postweld heat treatment. (2) Investigate welding defects, distortion, and the size accuracy of the weldment.	

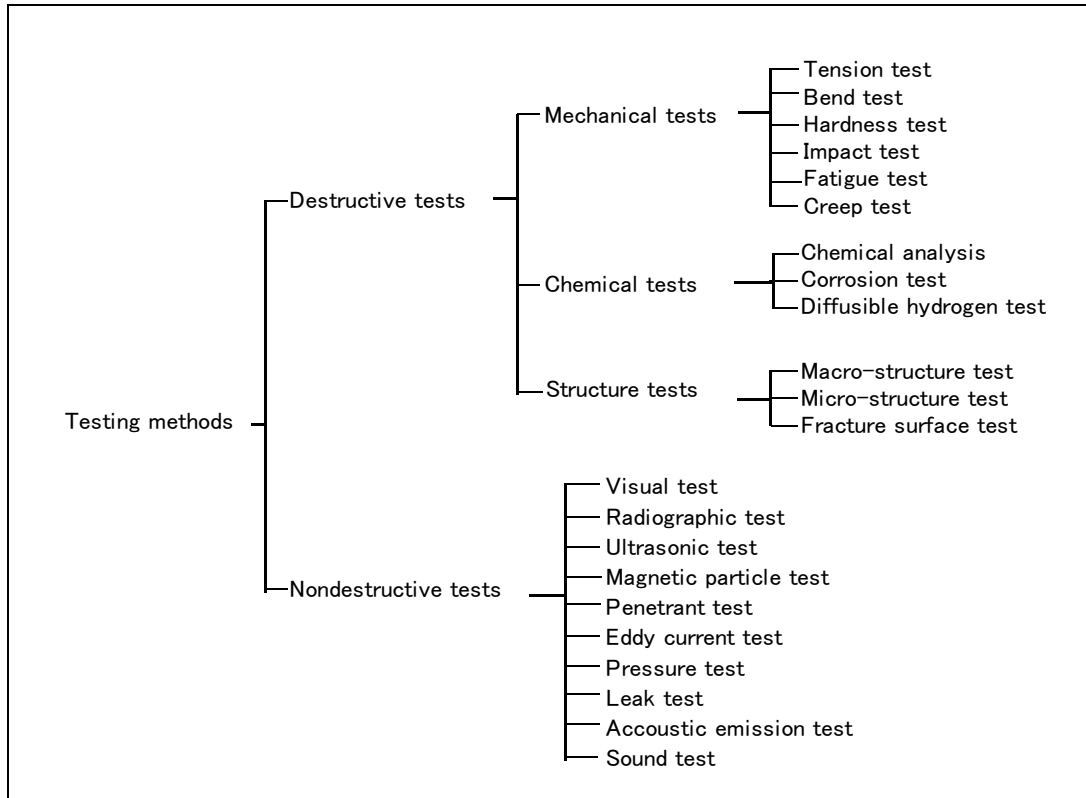

Fig. 6.1 — Classification of testing methods

## 6.1 Destructive tests

Destructive tests aim to examine the mechanical, chemical, and metallurgical properties of a weldment by breaking, deforming, or chemically processing test specimens removed from a welded joint. These tests are considered to be a direct method of examining the qualities of the weldment. The destructive tests can be classified into mechanical tests, chemical tests, and structure tests as shown in Fig. 6.1. The destructive tests are often used to confirm whether or not specific welding procedures can produce the required qualities of the weldment. The following sections outline the major destructive tests.

### 6.1.1 Mechanical tests

#### (1) Tension test

Tension tests examine yield strength, tensile strength, elongation and reduction in area by stretching a tension test specimen until it ruptures as shown in Figs. 6.2 and 6.3. The tension tests of a weld metal and a welded joint are conducted according to the specification to be followed. For fillet welds, the shearing strength of fillet joints is examined, using a tension test machine.

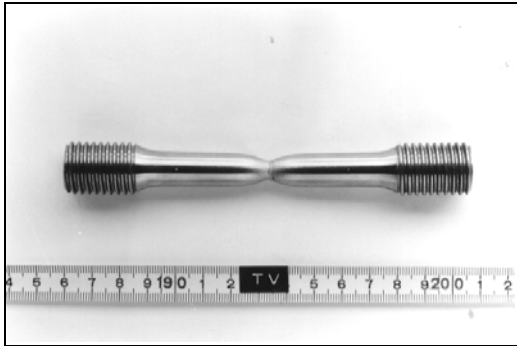

**Fig. 6.2 — A Tension test specimen after test**

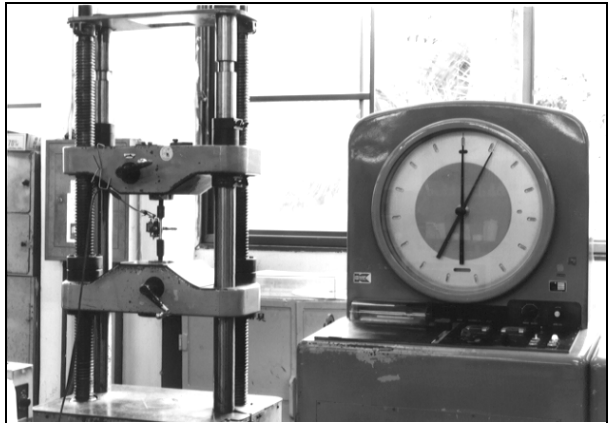

**Fig. 6.3 — A tension test machine**

## (2) Bend test

Bend tests examine the ductility of welds and whether they contain welding defects or not. Bend test specimens are usually removed from butt weld joints so that the weld is perpendicular to the longitudinal axis of the specimen. In bend tests, three different types of specimens are used, depending on the surface to be tested: face-bend specimens, root-bend specimens, and side-bend specimens. The bend tests include the roller bend test, guide bend test, and free bend test. Fig. 6.4 shows the tension surfaces of side bend specimens after a roller bend test was conducted by using a bend test machine as shown in Fig. 6.5.



**Fig. 6.4 — Side bend specimens after test**



**Fig. 6.5 — A bend test machine for roller bend test**

### (3) Impact test

Metals may be fractured in the ductile mode or brittle mode depending on the environment where the metals are loaded. The fracture of a metal with plastic deformation in standard tensile testing and slow bend testing is considered ductile fracture. Ductile metals (as judged by tensile or bend tests), however, may fracture with little or no plastic deformation, when subjected to critical testing or service conditions. This type of fracture is considered brittle fracture. The critical conditions depend on the fracture toughness of the metal. The brittle fracture is considered more dangerous because a high-velocity failure takes place in steel structures. Three factors markedly influence the brittle fracture behavior of a metal; namely, (1) the presence of a notch in the metal, (2) the temperature of the metal, and (3) the residual and applied stresses in the metal. For examining the fracture toughness of a weldment, various testing methods are available. In particular, Charpy impact testing of V-notch specimens is most widely used. Fig. 6.6 shows the fracture surfaces of Charpy impact test specimens, and Fig. 6.7 shows a Charpy impact test machine.



**Fig. 6.6 — Fracture surfaces of Charpy impact test specimens after test**

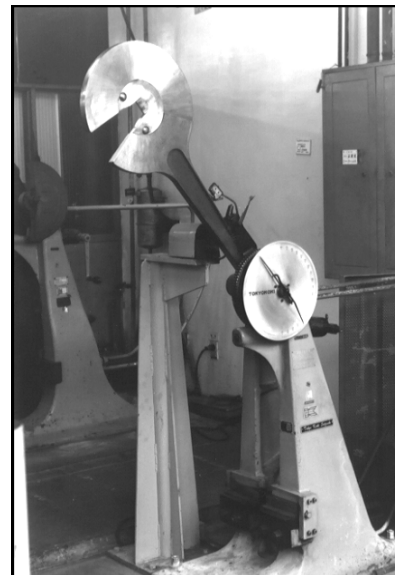

**Fig. 6.7 — A Charpy impact test machine**

### (4) Hardness test

The hardness of a weld is the ability to resist indentation or penetration by the point of a material that is harder than the weld being tested. The hardness test is required to confirm whether or not the weld is hard enough to resist mechanical wearing, or whether or not the weld is ductile enough to stresses, depending on the usage of the weldment. Four different methods of measuring hardness are in use depending upon the requirement: Brinell, Rockwell, Vickers, and Shore hardness. In particular, Vickers hardness is most suitable to measure the hardness distribution in a weld. A Vickers hardness tester, as shown in Fig. 6.8, uses a sharp diamond quadrangular pyramid for the indenter which is applied under a standard load, and measures the hardness from the amount of penetration into the weld.



**Fig. 6.8 — A Vickers hardness tester**

### 6.1.2 Structural test

#### (1) Macrostructure test

Macrostructure test is conducted by naked eyes to examine the penetration of a weld, the status of weld layers, the size of the heat-affected zone, and the occurrence of welding defects. In preparing a macrostructure specimen, the cross section of a weld is finished smooth and etched by applying a suitable etching acid (such as 5% picric acid or nitric acid for carbon steel and low-alloy steel). Fig. 6.9 shows a macrostructure of weld.

#### (2) Microstructure test

In this test, the cross section of a weld is smoothly polished, etched with a suitable etching acid, and magnified by 100 to 1000 times by an optical microscope. Crystallized microstructure, minute cracks, and inclusions in the specimen can be investigated. Electron microscopes are used for investigation by high magnification of over 1000 times up to multimillion times. Fig. 6.10 shows the microstructure of a ferritic deposited metal magnified by 200 times.

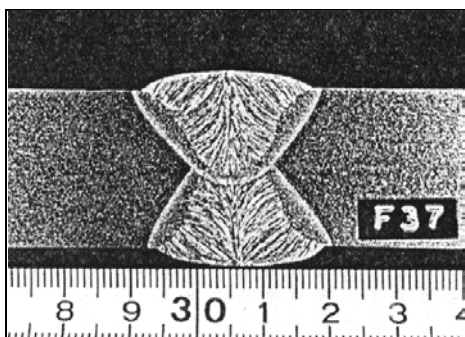

**Fig. 6.9 — A macrostructure of weld**

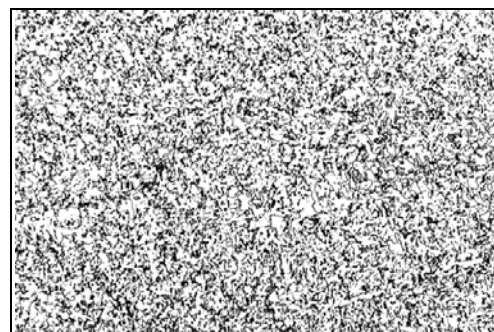

**Fig. 6.10 — A microstructure of deposited metal (x 200)**

## 6.2 Nondestructive tests

In order to guaranty the quality of a welded structure, it is indispensable to know what welding defects may or may not exist in the welds. For this purpose, a welded structure could be examined by using a destructive test after fabrication; however, the tested structure becomes out of use if it is fractured by the test. Therefore, destructive tests are conducted with test specimens, not with a product (except for the sampling test for small products). Since finished products should never be fractured by a test, it is important to examine the soundness of the welds of the products without breaking them. For this purpose, nondestructive tests are conducted.

Nondestructive tests can detect defects in welds by utilizing radiation, ultrasonic waves, electricity, magnetism, or light. The following paragraphs outline the main nondestructive tests.

### 6.2.1 Visual test (VT)

A visual test is used to examine the appearance, width and thickness of a weld and the welding defects such as undercut, overlap, cracks, pits, and slag inclusions in the surfaces of a weld. It is also used to check whether the throat thickness is as thick as specified and the misalignment is within the allowance. This test is simple, inexpensive, and is capable of examining many weld zones at one time. Therefore, it is commonly applied to all welds.

### 6.2.2 Radiographic test (RT)

When an accelerated electron hits a target of heavy metal, the radiation emanates. This radiation is a kind of electromagnetic wave. As its wavelength is shorter, its penetrative capacity becomes stronger. This penetrable capacity is used in the X-ray test to detect defects inside welds. Weld zones can also be examined utilizing the radioactive isotopes ( $^{60}\text{Co}$ ;  $^{192}\text{Ir}$ , etc.) that emit  $\gamma$ -rays. These two methods using X-rays and  $\gamma$ -rays are called the radiographic test. Fig. 6.11 shows a typical arrangement for X-ray testing: X-ray source, weldment, radiographic film cassette, and other tools such as penetrometer and contrastmeter for evaluating the X-ray image quality. Fig. 6.12 shows an X-ray unit and a weldment for RT.

The extent of X-ray penetration varies depending on the kind and thickness of the test material. The radiation intensity changes at where there is a welding defect, reflecting a change in photosensitivity. The radiation intensity becomes denser at most defects except for tungsten inclusions. Darker portions in the negative film indicate the existence of such defects as blowholes, lack of fusion, lack of penetration, slag inclusions, cracks, and undercut. A brighter spot in the negative film indicates a tungsten inclusion, because tungsten absorbs the radiation at a high degree. In taking radiophotographs, an Image Quality Indicator (I.Q.I.) and contrastmeter are used in order to confirm the quality of radiophotographs.



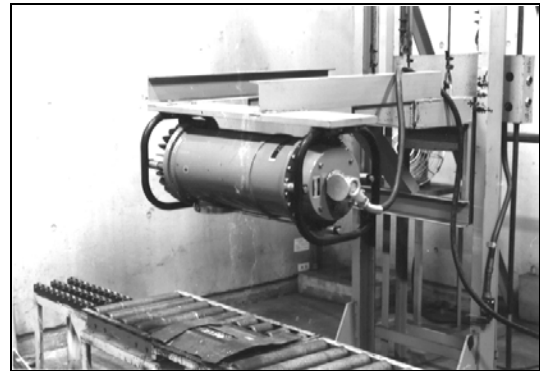
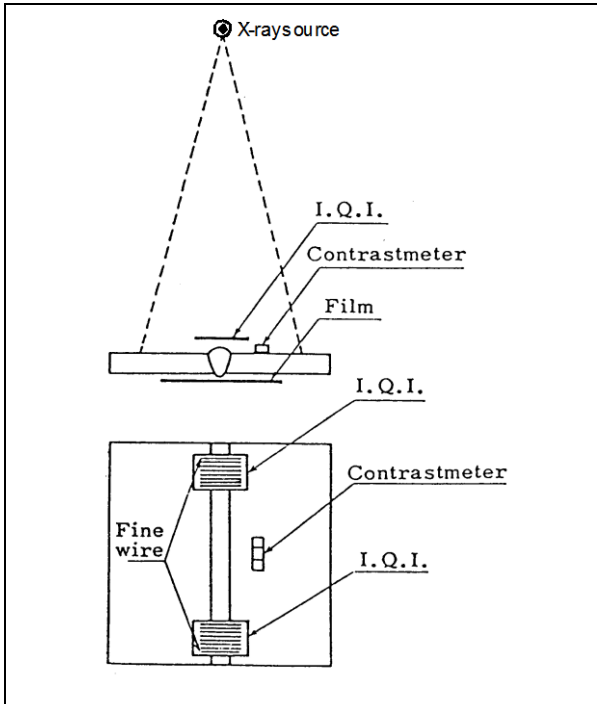

Fig. 6.12 — An X-ray unit and a weld for RT

Fig. 6.11 — Arrangement of equipment and materials in RT

### 6.2.3 Ultrasonic test (UT)

In ultrasonic testing, beams of high frequency sound waves or inaudible, short sonic waves of 0.5-15 MHz are introduced into a test object to detect and locate surface and internal discontinuities. A sound beam is directed into the test object on a predictable path, and is reflected at interfaces or other interruptions in material continuity. The reflected beam is detected and analyzed to define the presence and location of discontinuities. The principle of UT is outlined in Fig. 6.13, and Fig. 6.14 shows an apparatus for UT.

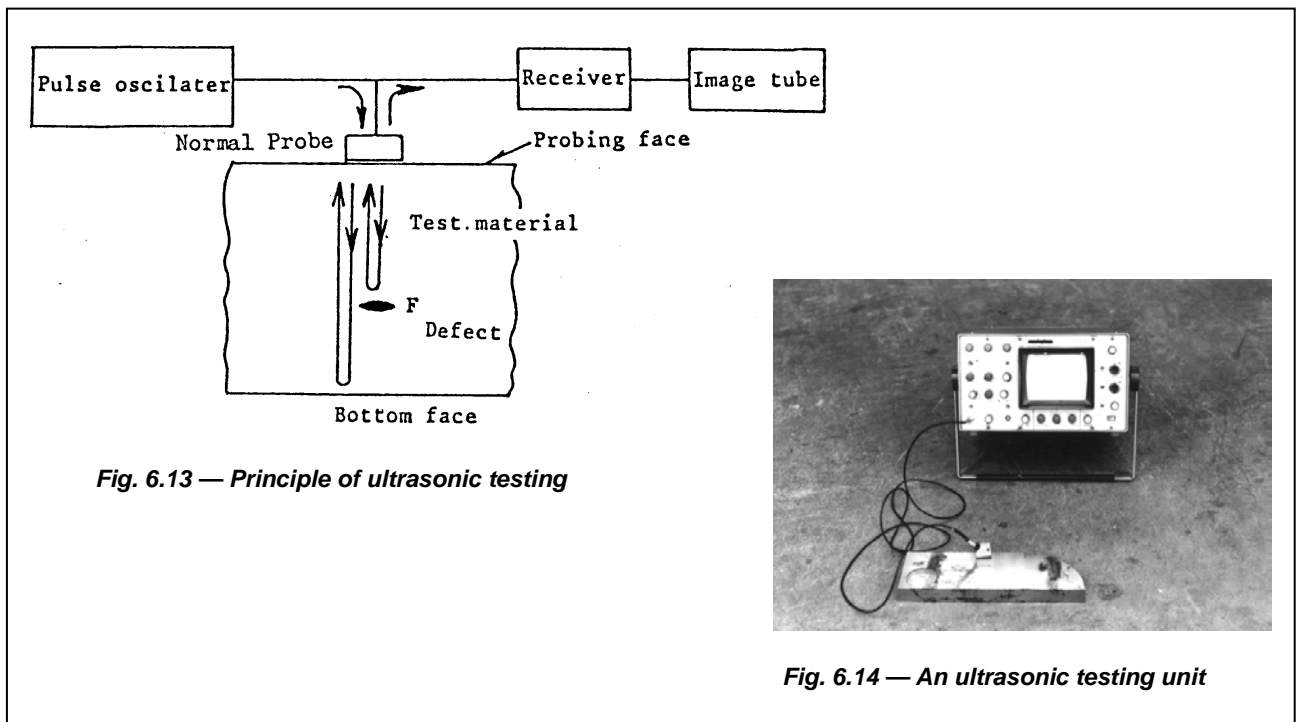

Fig. 6.13 — Principle of ultrasonic testing

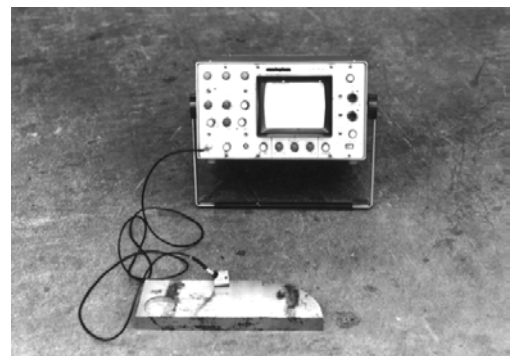

Fig. 6.14 — An ultrasonic testing unit

### 6.2.4 Magnetic particle test (MT)

Irons and ferritic steels can easily be magnetized by a magnet. Therefore, if there is any defect on or near the surfaces of a weldment, the magnetic poles will be developed on both sides of the defect, producing the leaked magnetic flux as shown in Fig. 6.15. When fine magnetic particles are brought near the periphery of this magnetic flux, the particles are magnetized, and the magnetic poles are developed at both ends of each particle as shown in Fig. 6.16. The magnetic power acts through the magnetic poles of the particles and defective zone. Consequently, the particles are connected each other to develop a particle pattern like a chain. For the magnetic particles, either a dry powder or liquid suspension powder is used.

By using this method, defects such as cracks and porosity which are open to or close to the surface of a weldment can be detected. Minute defects cannot easily be detected, and this method is not applicable to austenitic stainless steel weldments and other nonmagnetic materials. For this test, both the yoke method and the prod method as shown in Fig. 6.17 are widely used since they are portable. The prod method, however, is not suitable for testing high strength steels, because this method tends to generate an arc during testing; the arc may cause hair cracks in the test assembly.

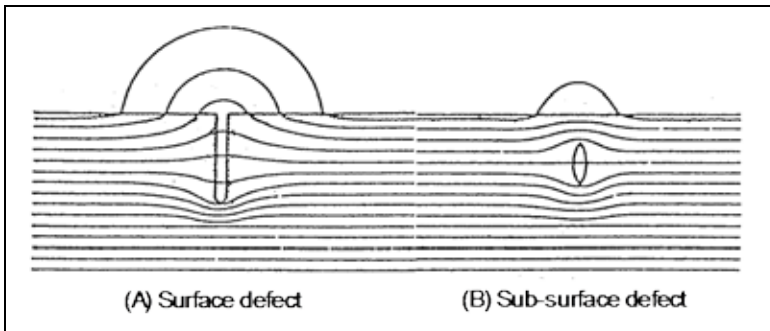

Fig. 6.15 — Leaked magnetic flux lines caused by defects

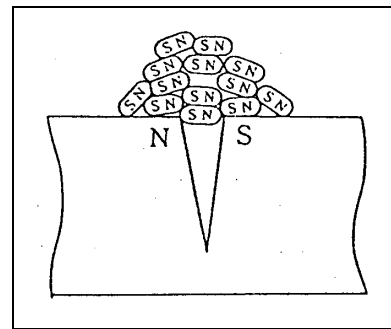

Fig. 6.16 — Magnetic particle chain

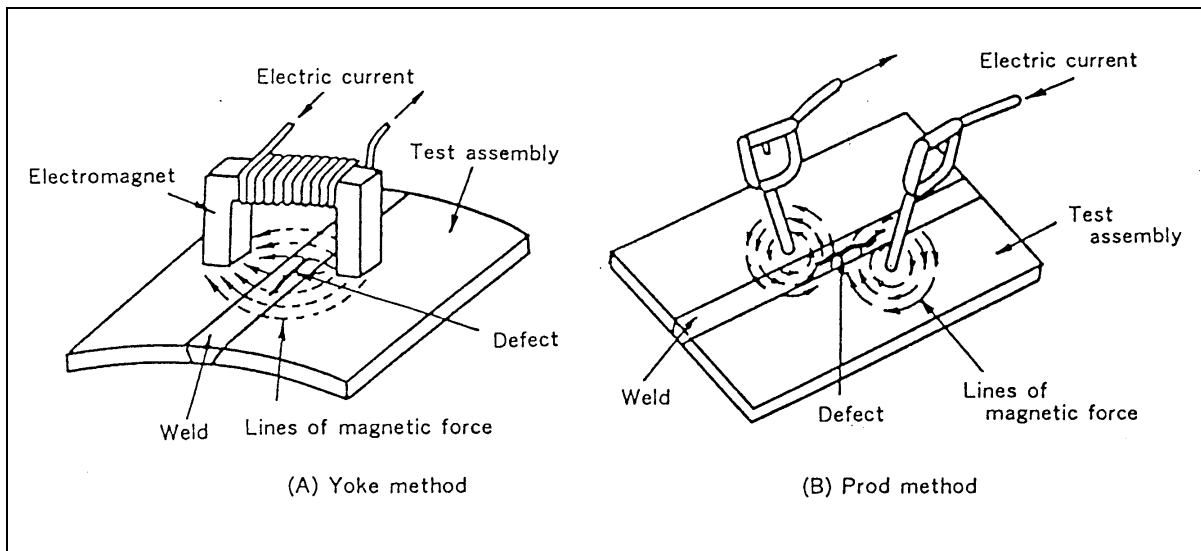

Fig. 6.17 — Typical MT methods

### 6.2.5 Penetrant test (PT)

The penetrant test uses fluorescent or red penetrant to visualize defects such as cracks and pits that open to the surface of a weld zone. Fig. 6.18 shows the procedure of the penetrant test. If there is any defect that is open to the surface of a weld, the applied penetrant penetrates into it. After it has fully penetrated the surface is cleaned with water or solvent depending on the type of penetrant. When a developing solution is applied, the penetrant left in the defect comes to the surface exhibiting an indication pattern. The pattern is easily identifiable because it is either fluorescent (fluorescent penetrant test) or red (dye penetrant test) depending on the type of penetrant. In this test, even a minute defect can easily be detected.

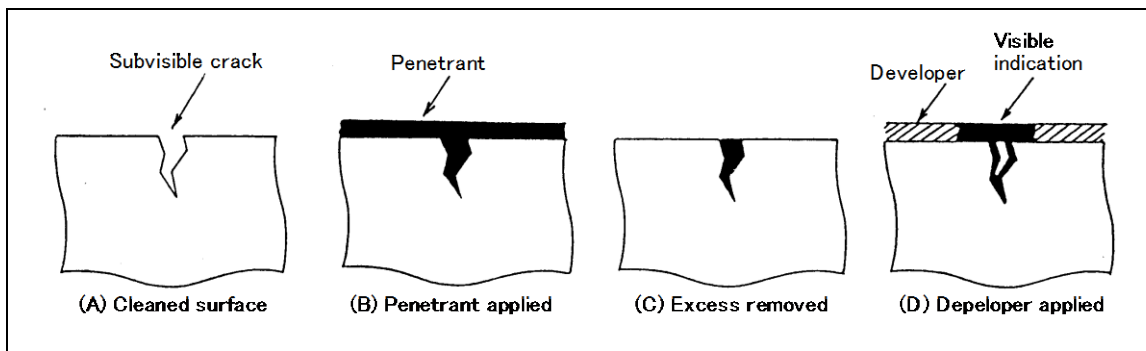

Fig. 6.18 — Penetrant test procedure

### 6.2.6 Applicability of nondestructive tests

Table 6.2 relates nondestructive tests to the various types of discontinuities. Other factors must also be considered before the examination method may be reliably chosen for consistent results. For example, the shape of the weld, the compatibility of the material with the chosen method, and the welding process all affect the choice of method. Table 6.3 relates joint types to applicable nondestructive test method. Further information is necessary before a preferred method can be chosen. Material type and shape, welding process, criticality level of the weldment, and unacceptable discontinuity types must be considered in selecting the most suitable examination method. For the latest information, refer to AWS B1.10:2009 (Guide for the Nondestructive Examination of Welds). RT, UT, PT, MT, and VT stand for radiographic test, ultrasonic test, penetrant test, magnetic particle test, and visual test, respectively.

**Table 6.2 — Nondestructive tests vs. discontinuities (Excerpted from AWS B1.10:1999)**

Discontinuities	RT	UT	PT	MT	VT
Porosity	A	O	A(1)	O(2)	A(1)
Slag inclusions	A	O	A	O(2)	A(1)
Incomplete fusion	O	A	U	O(2)	O(1)
Incomplete joint penetration	A	A	U	O(2)	O(1)
Undercut	A	O	A	O	A
Overlap	U	O	A	A	O
Cracks	O	A	A(1)	A(2)	A(1)

Note (1) Surface

(2) Surface and slightly subsurface

A: Applicable method

O: Marginal applicability (depending on other factors such as material thickness, discontinuity size, orientation, and location)

U: Usually not used

**Table 6.3 — Nondestructive tests vs. weld joint types (Excerpted from AWS B1.10:1999)**

Types of weld joints	RT	UT	PT	MT	VT
Butt joints	A	A	A	A	A
Corner joints	O	A	A	A	A
Tee joints	O	A	A	A	A
Lap joints	O	O	A	A	A
Edge joints	O	O	A	A	A

Note A: Applicable method

O: Marginal applicability (depending on other factors such as material thickness, discontinuity size, orientation, and location)

