

Welding Consumables for Oil Storage Tank

Main joint	Type of steel (1)	Welding position	Welding process	Filler metal	ASME/AWS	Polarity	Joint Configuration
Roof plate joint	Mild steel	Horizontal fillet	SMAW	FAMILIARC [™] LB-47 FAMILIARC [™] LB-52	SFA/A 5.1 E7016	AC/ DCEP	
Shell plate joint	Mild steel	Horizontal	SAW (Flux/Wire)	FAMILIARC [™] MF-33H / FAMILIARC [™] US-36	SFA/A 5.17 F7A6-EH14	DCEP	
	HT steel			FAMILIARC [™] MF-33H / TRUSTARC [™] US-49	SFA/A 5.23 F8A6-EG-A4	DCEP	
	Mild steel		SMAW	FAMILIARC [™] LB-47 FAMILIARC [™] LB-52	SFA/A 5.1 E7016	AC/ DCEP	
	HT steel			TRUSTARC [™] LB-62 TRUSTARC [™] LB-62UL	SFA/A 5.5 E9016-G	AC/ DCEP	
	Mild steel	Vertical	EGW	FAMILIARC [™] DW-S43G	SFA/A 5.26 EG70T-2	DCEP	
	HT steel			TRUSTARC [™] DW-S60G	---	DCEP	
	Mild steel		SMAW	FAMILIARC [™] LB-47 FAMILIARC [™] LB-52	SFA/A 5.1 E7016	AC/ DCEP	
	HT steel			TRUSTARC [™] LB-62 TRUSTARC [™] LB-62UL	SFA/A 5.5 E9016-G	AC/ DCEP	
Shell plate to annular plate joint	Mild steel	Horizontal fillet	SAW	FAMILIARC [™] FAMILIARC [™] MF-300/US-36	SFA/A 5.17 F7A6-EH14	AC/	
	HT steel			FAMILIARC [™] TRUSTARC [™] MF-300/US-40	SFA/A 5.23 F9A4-EA3-A3	DCEP	
	Mild steel		SMAW	FAMILIARC [™] FAMILIARC [™] LB-47/LB-52	SFA/A 5.1 E7016	AC/	
	HT steel			TRUSTARC [™] TRUSTARC [™] LB-62/LB-62UL	SFA/A 5.5 E9016-G	DCEP	

(1) HT steel: 550-610 MPa HT steel (2) Dissimilar: Mild steel and 550-610 MPa HT steel

Main joint	Type of steel (1)	Welding position	Welding process	Filler metal	ASME/AWS	Polarity	Joint Configuration
Annular plate joint	Mild steel	Flat	SAW	FAMILIARC [™] FAMILIARC [™] MF-300/US-36	SFA/A 5.17 F7A6-EH14	AC/	
	HT steel			FAMILIARC [™] TRUSTARC [™] MF-300/US-40	SFA/A 5.23 F9A4-EA3-A3	DCEP	
	Mild steel		SMAW	FAMILIARC [™] FAMILIARC [™] LB-47/LB-52	SFA/A 5.1 E7016	AC/	
	HT steel			TRUSTARC [™] TRUSTARC [™] LB-62/LB-62UL	SFA/A 5.5 E9016-G	DCEP	
Annular plate to bottom plate joint	Mild steel or dissimilar (2)	Flat	SAW	FAMILIARC [™] MF-300/US-36	SFA/A 5.17 F7A6-EH14	AC	
			SMAW	FAMILIARC [™] LB-47/LB-52	SFA/A 5.1 E7016	AC/ DCEP	
Bottom plate joint	Mild steel	Horizontal fillet and flat	SAW	FAMILIARC [™] FAMILIARC [™] MF-300/US-36	SFA/A 5.17 F7A6-EH14	AC	
			SMAW	FAMILIARC [™] LB-47/LB-52	SFA/A 5.1 E7016	AC/ DCEP	
Joints at the periphery of nozzle and manhole	Mild steel	Horizontal fillet and flat	SMAW	FAMILIARC [™] FAMILIARC [™] LB-47/LB-52	SFA/A 5.1 E7016	AC/	
	HT steel			TRUSTARC [™] TRUSTARC [™] LB-62/LB-62UL	SFA/A 5.5 E9016-G	DCEP	
	Mild steel		GMAW	FAMILIARC [™] MG-50	SFA/A 5.28 ER70S-G	DCEP	
	HT steel			TRUSTARC [™] MG-60	SFA/A 5.28 ER80S-G	DCEP	
	Mild steel		SAW	FAMILIARC [™] FAMILIARC [™] MF-300/US-36	SFA/A 5.17 F7A6-EH14	AC/	
	HT steel			FAMILIARC [™] TRUSTARC [™] MF-300/US-40	SFA/A 5.23 F9A4-EA3-A3	DCEP	

Outline of Horizontal Submerged Arc Welding

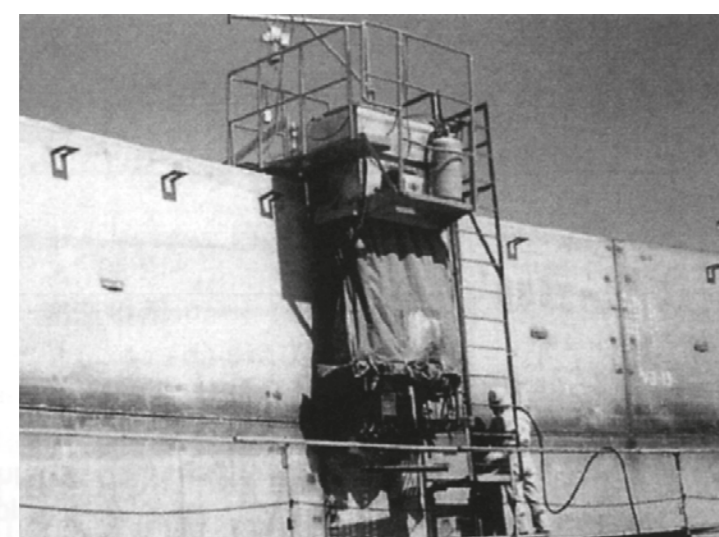
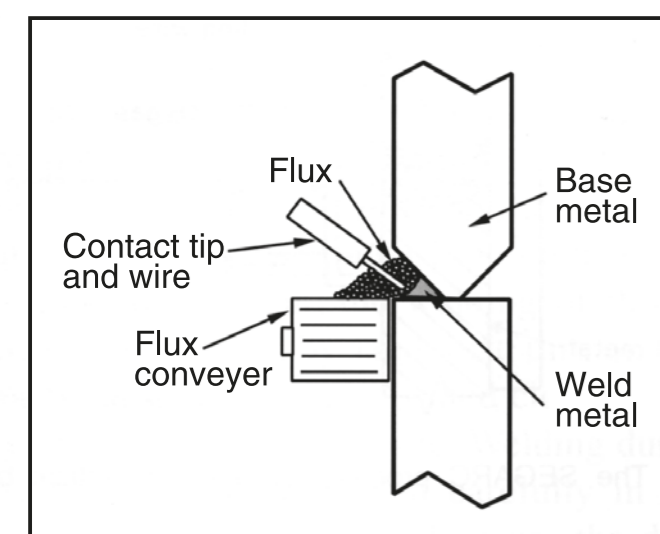

The SEGARC Process for One-run Vertical Butt Welding

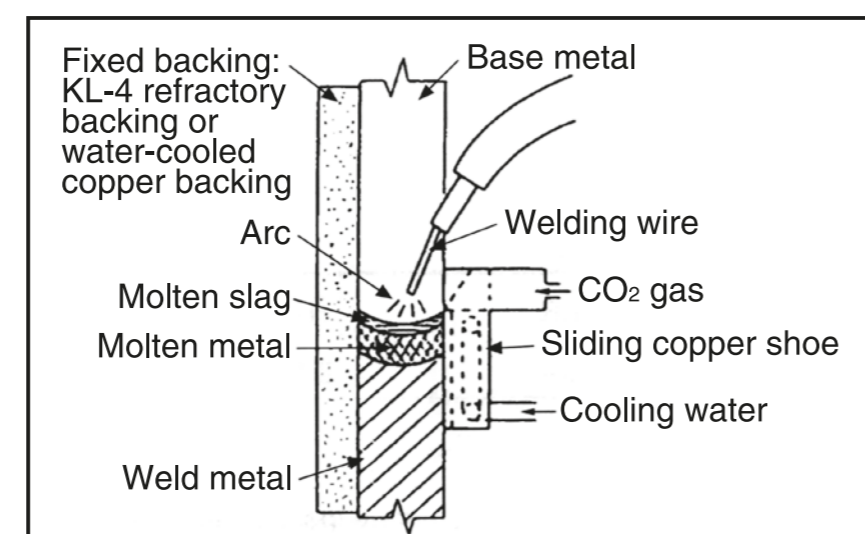

Electrogas Welding



With SEGARC-2Z & DW-S43G

