

# Technical Developments and Recent Trends in Crankshaft Materials

Haruyoshi KUBO, Technology Department, Steel Casting & Forging Plant, Steel Casting & Forging Division, Iron & Steel Sector  
Dr. Hiroyuki MORI, Production Department, Steel Casting & Forging Plant, Steel Casting & Forging Division, Iron & Steel Sector

*Diesel engines are required to have higher out-puts with smaller sizes. Semi-built-up and solid crankshafts, which are main parts of diesel engines, are subject to severer service conditions to meet such requirements. As a result, crankshaft manufacturers are driven to improve fatigue strength, quality and reliability of the crankshafts. This article describes technical developments and recent trends in crankshaft manufacturing, including steel-making processes, new materials with higher strength, and new fillet hardening processes.*

## Introduction

A crankshaft for vessel engine is one of the most vital parts for ships. Crankshafts are roughly classified into two categories; built-up type crankshafts for 2-cycle diesel engines and solid type crankshafts for 4-cycle diesel engines.

Built-up type crankshafts are made by shrink-fitting journals to crankthrows for the numbers of cylinders and are widely used for marine diesel engines with cylinder bore-diameters larger than approx. 400 mm. The two oil shocks forced low-speed, two cycle, engine manufacturers to pursue lower energy consumptions and lower fuel costs. As a result, the engine strokes have become longer and the cylinder pressures have become higher. Also, the recent increasing size of ships has resulted in a requirement for higher powers and, at the same time, the needs to reserve maximum cargo space require downsizing of engines. The technical trend in the low-speed engine requires the built-up type crankshafts to have higher strength and higher reliability.

Solid type crankshafts are press-formed from steel ingots and are used for mid- to high-speed, four cycle, engines with cylinder bore-diameters of less than 600 mm. Several developments are progressing for the 4 cycle engines to improve overall efficiencies. These include higher cylinder pressures, longer strokes and utilization of exhaust energy. As in the case of built-up type crankshafts, longer strokes and down-sizing are required for solid type crankshafts. An important requirement for solid type crankshafts is strength. Some of the

engines employ materials with strength as high as 950 MPa. Along with the strengthening of materials, higher reliabilities are required more than ever for the crankshafts.

This article describes the technical history of crankshaft materials and refers to notable trends in their technical developments.

## 1. Manufacturing methods for crankshafts

### 1.1 Manufacturing method of built-up type crankshafts

**Photo 1** shows an example and **Figure 1** shows the names of parts of a built-up type crankshaft. As described above, a built-up type crankshaft is made by shrink fitting parts called "journals" to other parts called "crankthrows". All the journals are made of forged steel and the crankthrows are made of either cast or forged steel. The crankthrows made of cast steel have advantage in productivity over the ones made of forged steel. **Table 1** shows a typical manufacturing process for a built-up type crankshaft with cast steel crankthrows. Elemental technologies required for the crankshaft with cast steel crankthrows are



Photo 1 Built-up type crankshaft

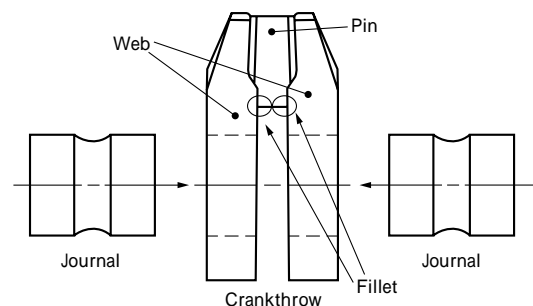

Fig. 1 Illustration of built-up type crankshaft

Table 1 Manufacturing sequence of built-up type crankshaft made of cast steel crankthrow

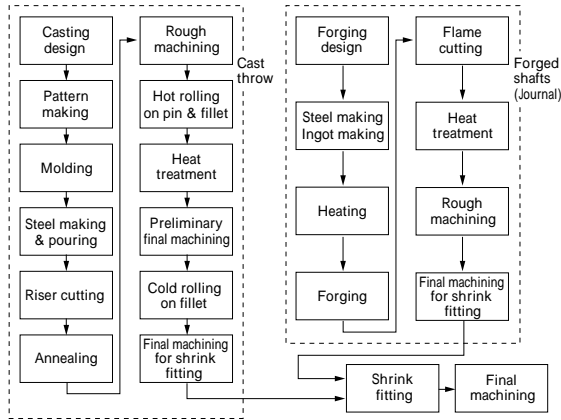

Photo 2 Solid type crankshaft

casting design, steel making and material technology and strengthening of crankshaft.

## 1.2 Manufacturing method of solid type crankshafts

Photo 2 shows an example and Table 2 shows a typical manufacturing process of solid type crankshafts. Solid type crankshafts are made from ingots of steel, which are forged into pre-designed shapes using special forging equipment. The special forging methods include the RR forging and TR forging, both of which are commonly used

Table 2 Manufacturing sequence of solid type crankshaft

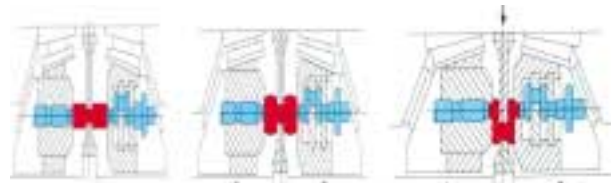
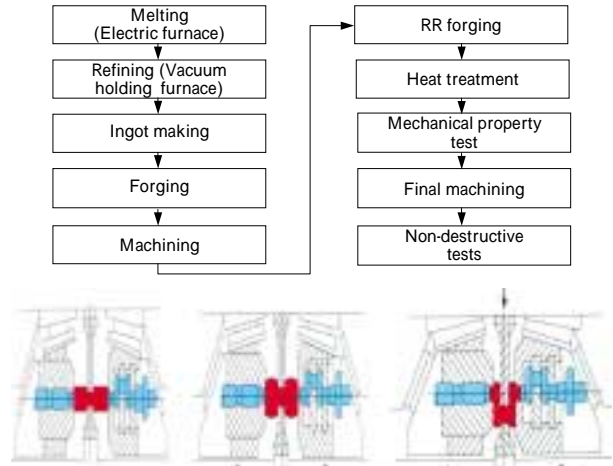

Fig. 2 RR forging

methods today. Figure 2 shows an example of the RR forging method used in our company. The RR (TR) forging method yields higher fatigue strength compared to free-forging because the outermost layers of steel ingots appear on fillets which are the most important portions of crankshafts. The important elemental technologies required for solid type crankshafts are forging method, steel making and material technology and strengthening of crankshaft.

## 2. History and latest trend of materials for built-up type crankshafts

### 2.1 History of main elemental technologies for built-up type crankshafts

Table 3 shows the technical developments of built-up type crankshafts. The following describes the

Table 3 Technical development of built-up type crankshaft

	1950	1955	1960	1965	1970	1975	1980	1985	1990	1995	2000	2005
Casting design	Full built-up type											
							Semi built-up type crankthrow					
							Solidification analysis			Mold filling and solidification analysis		
Steel making process	Open-hearth furnace											
							Electric furnace					
	Tap degassing process (TD method)						Ladle furnace process (LF)					
Cast steel material	Grade 1											
							Grade 2			Grade 3		
										Grade 4		
										Grade 5		
										Low-Si		
Fillet rolling	Cold rolling (Old type equipment)											
							Cold rolling (New type/Small size)			Cold rolling (New type/Large size)		
							Hot rolling					
Ultrasonic test apparatus	Automatic apparatus											

history and trend of steel making process, materials, and additional technologies.

## 2.2 History of steel making technology

Advances in steel making technology are essential for reducing impurities in the materials for crankshafts. The removal of phosphorous (P) and sulfur (S) are especially important along with degassing. As shown in Table 3, we used the tap degassing process (TD process) until around 1988. Subsequently we employed the ladle furnace process (LF process) in which the molten steel is transferred from an electric furnace to a ladle and refined in there. A schematic of the LF process is shown in **Figure 3** and the result of refining is shown in **Figure 4**. The LF process efficiently removes impurities such as sulfur, and gasses such as oxygen, and is proven to be an effective method of reducing non-metallic inclusions.<sup>1)-3)</sup>

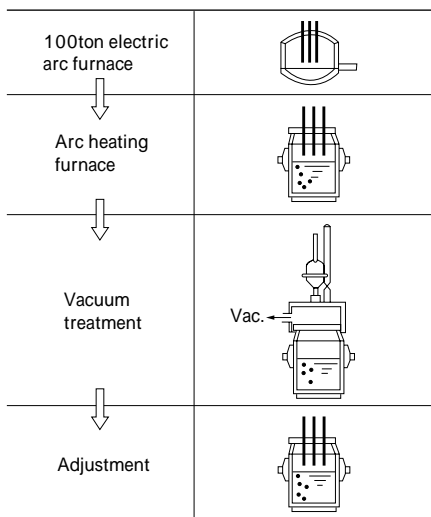

Fig. 3 Ladle furnace process

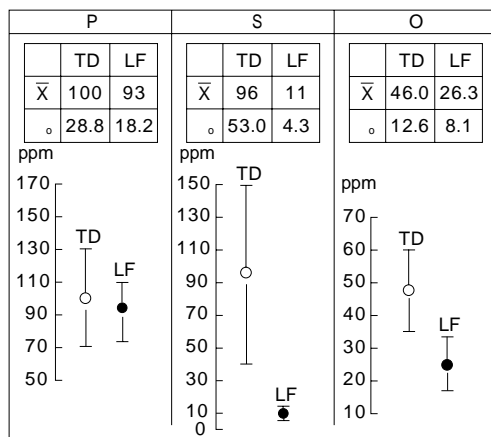

Fig. 4 Comparison of P, S and O contents between tap degassing process and ladle furnace process

## 2.3 History of materials

The down-sizing and high-power generation of diesel engines require higher fatigue strengths of the pin fillets and improved gripping strength of the shrink fit journals. **Figure 5** shows the mechanical properties and heat treatments of cast steel crankthrows developed to date. In the last 30 years the yield point of the material has increased by a factor of 1.5.

## 2.4 History of additional technologies

The most important characteristic of a crankshaft is the fatigue strength of fillets. One way to improve the fatigue strength further is by applying external forces to the material surface. We have developed a strengthening method of cold rolling the fillets (**Photo 3**, cold rolling method) and have adopted the method in production. Various improvements have been made on the fillet, cold rolling, equipment to roll in the narrow spaces of the pin-fillet between large webs, which are becoming even narrower with the down-sizing of diesel engines.<sup>1), 4)</sup> A significant improvement in fatigue strength is obtained by the cold rolling, which causes work hardening and compressive residual stress on the material surface.<sup>5)-12)</sup> The effect of cold rolling is confirmed on actual-sized crankthrows using our in-plane, resonance type, fatigue testing machine

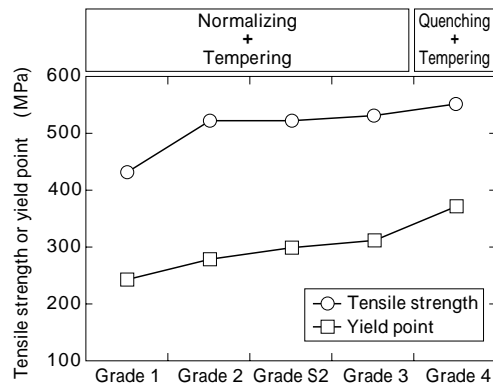

Fig. 5 Mechanical properties and heat treatment of cast steel materials for crankthrow



Photo 3 Fillet cold rolling equipment



Photo 4 Fatigue testing machine for actual-sized crankthrow

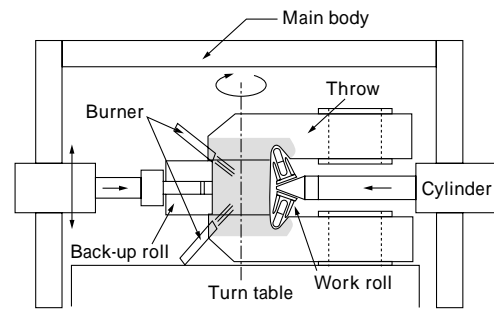

Fig. 7 Illustration of hot rolling

Table 4 Results of fatigue tests on actual-sized crankthrow

Type of crankshaft (Pin diameter in mm)	Material	Fillet cold rolling	Tensile strength <sub>B</sub> (MPa)	Fatigue strength		
				Fatigue strength <sub>w</sub> (MPa)	Degree of increase	
					Amount (MPa)	Rate (%)
Type 80 (730)	Cast steel (Grade 2)	Non	557.6	176.4	-	-
		Treated	557.6	313.6	137.2	78

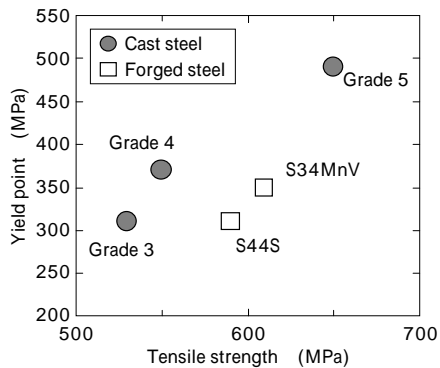

Fig. 6 Mechanical properties of cast steel materials and forged steel materials for crankthrow

shown in **Photo 4**. **Table 4** summarizes the results of fatigue tests, showing 78% increase of the fatigue strength by cold rolling. All the cast crankthrows produced today are processed by cold rolling.

## 2.5 Latest trend

The built-up type crankshaft, using cast-steel crankthrows, has been regarded to be superior in productivity but inferior in fatigue strength compared to the one using forged-steel crankthrows. Therefore some type of engines restricted the use of cast-steel crankthrows.

We have developed a high strength, cast steel for crankshaft throws (Grade 5) having fatigue strength comparable to the forged ones.<sup>13)</sup> **Figure 6** shows the relationship between the yield point and tensile strength of cast steels and forged steels. The high strength cast steel (Grade 5) enables the application of the same crankshaft designs as used for forged steel.

The inherent micro-shrinkages in cast throws

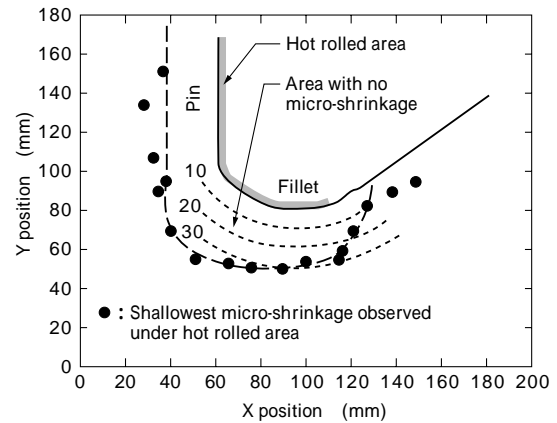

Fig. 8 Effect of hot rolling



Photo 5 Automatic ultrasonic inspection equipment

are known to yield slightly lower fatigue strength compared to the forged throw of the same strength level. We apply hot plastic forming (hot rolling) to important parts including pins and pin-fillets. **Figure 7** shows the hot-rolling equipment and **Figure 8** shows the effect of hot rolling. As shown in the figure, the micro-shrinkages within 20 mm depth from the surface disappeared due to the press-bonding by the hot rolling.<sup>14)</sup>

A crankshaft is an important part which requires very stable performance, and strict management is needed on its quality. The automatic ultrasonic inspection machine<sup>15)</sup> developed (**Photo 5**) eliminates human measurement errors, and detects and records the positions and sizes of defects even within the acceptance limits.

### 3. History and latest trend of materials for solid crankshafts

#### 3.1 History of main technologies for the solid-type crankshaft materials

Mid- to high-speed diesel engines used for ships and power generators are tending towards higher power, lower fuel consumption and down-sizing. Higher strength is required more than ever for solid type crankshafts.

The RR forging and TR forging developed so far yield higher fatigue strength compared to free-forging, and the crankshafts forged by those methods, called CGF (Continuous Grain Flow) crankshafts, are widely used. Currently the majority of crankshafts are designed based on the CGF. The most important parts of a solid type crankshaft are also the fillets and various improvements of the fillets, including strengthening of materials, have been conducted for higher fatigue strengths.

#### 3.2 History of material strength and characteristics

Until around 1960, carbon steels of 450MPa class had been used for the solid type crankshaft. Subsequently, low-alloy steels began to be used and have gradually increased in usage. Currently more than 50% of crankshafts use low-alloy steels ( 800 MPa).

A noteworthy trend is the recent application of super-high strength steel of 950MPa class<sup>16)</sup> (Figure 9). The trend will continue and steels of 1,000MPa class will be used in the near future.

#### 3.3 History of additional technologies

A number of technologies, in addition to the strengthening of material, are utilized for the improvement of fatigue strengths of crankshafts.

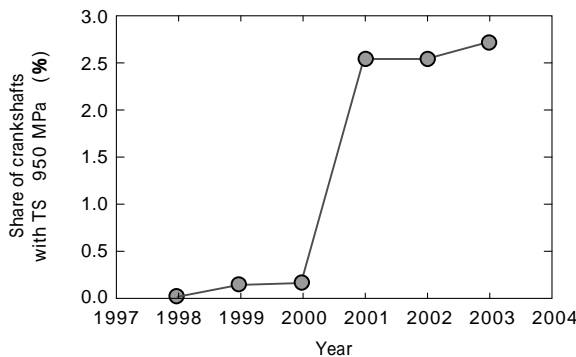

Fig. 9 Share of crankshafts with tensile strength of over 950 MPa

Such technologies include cold rolling, induction hardening, nitriding and shot-peening.<sup>17), 18)</sup> The cold rolling, among others, is one of the most commonly used techniques. The technique ensures high dimensional precision since it does not involve heating which tends to cause deformation and had been applied to the cast steel throw since around 1970 as described previously. We apply cold-rolling also to the solid type low-alloy crankshafts and confirmed its effect (Figure 10)<sup>11), 12)</sup> by using a fatigue testing machine as shown in Photo 6. These additional technologies are expected to be applied to an increasing number of crankshafts in the future.

#### 3.4 Latest trend

The trend for higher strength will accelerate in solid type crankshafts as described previously. The development of 1,000MPa class steel<sup>19)</sup> will be needed along with the reduction of non-metallic inclusions as suggested in the study by Nippon Kaiji Kyokai.<sup>20)</sup> Considerable achievement has been made in the reduction of non-metallic inclusions by the recent improvements in steel making technologies, however, we will continue development to further improve the quality.

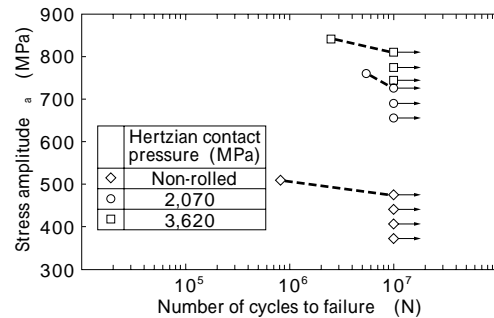

Fig.10 Results of fatigue tests on actual-sized crankthrow

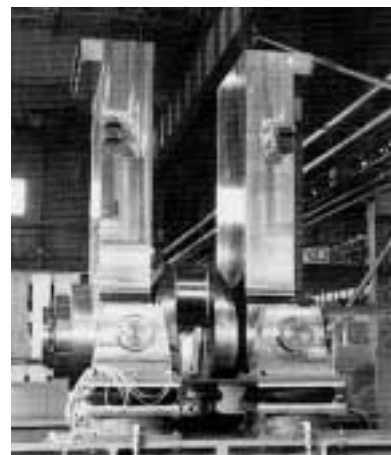

Photo 6 Fatigue testing machine

## Conclusions

The long history of crankshafts, which are one of our major product items, has been reviewed and major technologies have been described including their development background and recent trend. Diesel engines are excellent propulsion engines from the viewpoint of fuel economy and the crankshafts, being important parts of the diesel engines, are required to have higher performances and qualities. We will continue to respond the needs for crankshafts from the engine manufacturers by continuing further research and development.

## References

- 1) H. Mori, et al, *R&D Kobe Steel Engineering Reports*, Vol.50, No.3, p.41 (2000).
- 2) M. Okamura, et al., *R&D Kobe Steel Engineering Reports*, Vol.33, No.3, p.3 (1983).
- 3) A. Suzuki, *10th International Forging Conference Sheffield* (1985).
- 4) B. Ann, et al., *R&D Kobe Steel Engineering Reports*, Vo.19, No.2, p.88 (1969).
- 5) M. Nishihara, *Bulletin of the M.E.S.J.*, Vo.8, No.10, p.48 (1973).
- 6) M. Nishihara, *Bulletin of the M.E.S.J.*, Vol.2, No.2, p.57 (1974).
- 7) M. Nishihara, et al., *Bulletin of the M.E.S.J.*, Vol.5, No.5, p.22 (1970).
- 8) T. Kameoka, et al., *Trans. I. Mar. E.*, Vol.83, p.205 (1971).
- 9) M. Nishihara, et al., *9th International Congress on Combustion Engines*, A5 (1971).
- 10) M. Nishihara, et al., *Bulletin of the M.E.S.J.*, Vol.7, No.1, p.53 (1972).
- 11) S. Araki, et al., *21st International Congress on Combustion Engines*, D17 (1995).
- 12) H. Nagasaka, et al., *R&D Kobe Steel Engineering Reports*, Vol.48, No.1, p.68 (1998).
- 13) Y. Kagawa, et al., *Proc. 70th M.E.S.J. Symposium*, p.9 (2003).
- 14) T. Ochi, et al., *R&D Kobe Steel Engineering Reports*, Vo.52, No.1, p.11 (2002).
- 15) Y. Wasa, et al., *Tetsu-to-Hagane*, Vol.90, No.11, p.877 (2004).
- 16) Y. Kagawa, et al., *Proc. 68th M.E.S.J. Symposium*, p.157(2002).
- 17) JSME Data Book, *Fatigue of Metals*, (1965).
- 18) T. Shimamoto, et al., *Journal of Society of Automotive Engineers of Japan*, Vol.44, No.6, p.95 (1990).
- 19) S. Fukaya, et al., *Proc. 72th M.E.S.J. Symposium*, p.109(2004).
- 20) S. Omata, *Journal of Nippon Kaiji Kyokai*, No.262, ( ), p.35 (2003).