

Simulation and Evaluation Technique for Power System and Related Energy Saving on Hydraulic Excavator

Takao NANJO, Dr. Etsujiro IMANISHI, Mechanical Engineering Research Laboratory, Technical Development Group, KOBE STEEL, LTD.

Kazuhiro OOTANI, KOBELCO CONSTRUCTION MACHINERY CO., LTD.

Akira TSUTSUI, Production System Research Laboratory, Technical Development Group, KOBE STEEL, LTD.

A dynamic Simulation technique using SINDYS is proposed for evaluating the energy efficiency of the power system on the hydraulic excavator. An engine evaluation system is also developed for evaluating the engine fuel consumption and the matching between the engine and the hydraulic system, which is valuable system for newly developing hydraulic excavator. ACERA Geospec excavator series has been commercially available, through the successful development solving the trade-off between the emission regulation and fuel saving. This achievement was made possible through the dynamic simulation of the power system and the engine evaluation system.



Photo 1 ACERA Geospec

Introduction

Recent environmental concerns and raising oil price have increased the need for energy saving of hydraulic excavators, with newly developed power systems having higher efficiencies. It is difficult to measure energy losses of an actual hydraulic excavator in practical operation, because a multiplicity of actuators are operated simultaneously and detailed energy evaluation on them cannot easily be done.

We developed a non-linear, dynamic analysis code, SINDYS¹⁾, and have simulated various mechanical systems including hydraulic systems^{2), 3)}. For energy saving of excavators, we have applied SINDYS to the dynamic simulation of an excavator in practical operation, to evaluate energies of its power system in detail and to provide guidance for effective counter measures.

The regulations on exhaust emissions from construction machinery have tightened, under initiatives taken by Japan, Europe and USA, and excavators, as they globalize, have to be equipped with engines which meet all the regulations. Engine performance and response tend to be changed through tightening regulations, making it important to evaluate the matching between engines and hydraulic systems.

In response to this, an engine evaluation bench was developed to evaluate engine fuel consumption and matching with hydraulic systems under actual work loads. In addition, a Hardware In the Loop Simulation (HILS) system for engines was developed to enable simulation of work loads during practical operation in accordance with lever manipulations

and loading of the simulation results on the engines in real time.

This article first introduces an analysis-evaluation technology for the power system of hydraulic excavators in practical operation and an engine evaluation system, both of which were used in the development of ACERA Geospec (Photo 1), which achieved energy saving of 20% and was began to be sold by KOBELCO CONSTRUCTION MACHINERY CO., LTD. in 2006. Finally, the article reports evaluation results from an actual machine.

1. Analytic theory of a hydraulic-mechanical coupling system

Both the mechanical system, including three dimensional movements of attachments, and the dynamics of the hydraulic system, actuating the attachments, have to be taken into consideration for the dynamic simulation of a hydraulic excavator in practical operation. The analytic theory of such hydraulic-mechanical coupling system is first explained.

1.1 Dynamic equation for hydraulic-mechanical coupling systems

The dynamic equation, discretized by a Finite Element Method (FEM), is expressed by the following second order differential equation of motion;

$$Mu_{n+1} + C\dot{u}_{n+1} + Ku_{n+1} = f_{n+1} - \dot{f}_n \dots \dots \dots (1)$$

where, u_{n+1} , in the mechanical system, is the displacement vector at time t_{n+1} and, in the hydraulic

system, is a vector showing a state variable, such as the integral of hydraulic fluid flow rate. M , C , K are mass, damping and stiffness matrices respectively which are linearized at time t_n , f_{n+1} is an external force at time t_{n+1} and \bar{f}_n is a term for correction external force for linearization of a non-linear element force by a time step.

1.2 Analytic theory of mechanical system⁴⁾

When a body moves widely in a space, the geometrical nonlinearities of the element have to be taken into account. This article takes a beam element that moves in a three-dimensional space, as an example of such nonlinear elements. **Figure 1** shows element coordinate systems of beam elements, wherein the coordinate systems at the ends A and B at time t_n are ω_A , ω_B ; the coordinate systems rotating with node displacement at time t_{n+1} are ω'_A , ω'_B ; in which ω'_A , ω'_B are oriented in arbitral directions; ω''_A , ω''_B are coordinate systems having a common third axis with each other; and $\tilde{\omega}_A (= \tilde{\omega}_B)$ are coordinate systems having common axis. The rotational deformation vector due to elastic deformation is obtained from the transformation matrix from $\tilde{\omega}_A$ to ω'_A . Potential energy is obtained from the rotational deformation vector, taking its second order term into consideration, and the geometric stiffness matrix k_g is obtained by deriving by the displacement two times. On the other hand, the following incremental element stiffness equation is obtained, where k_0 is the element stiffness matrix in the conventional linear theory.

$$(k_0 + k_g) u' = f' \dots\dots\dots(2)$$

The above equation is transformed to the total coordination system to give the follows;

$$K_T u = f \dots\dots\dots(3)$$

where,

$$K_T = T^T (k_0 + k_g) T \dots\dots\dots(4)$$

T is a coordinate transformation matrix from the total coordination system to $\tilde{\omega}_A$, which enables strict determination of large displacements when used with a rotation matrix. The equation (3) is transformed to the total displacement by introducing the correction

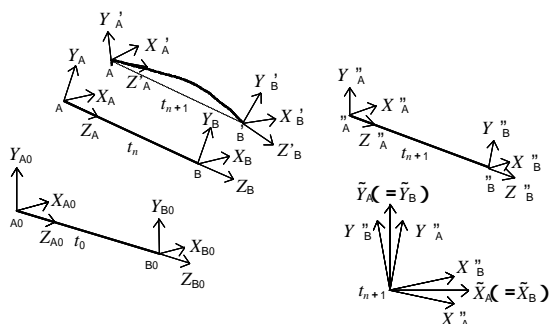

Fig. 1 Element coordinate systems of beam element

external force \bar{f}_n and combined to the dynamic equation (1). The theory applies to large displacement truss elements in a similar manner.

1.3 Analytic theory of hydraulic system⁵⁾

A cylinder element is considered as a basic element in a hydraulic-mechanical coupling analysis. The cylinder is assumed to have a stroke of the telescopic motion, according to flow in and out of hydraulic oil from a port, and to change its pressure corresponding to the load applied to the element edges. The relation between the increment u' in the integral of hydraulic fluid flow rate and increment p' in pressure is determined in the element coordinate system. The following equation is obtained by transforming the relation into the relations between the increments u in node displacement, u_p in the integral flow rate, f in node force and p in the port pressure;

$$\begin{Bmatrix} f_A \\ f_B \\ p \end{Bmatrix} = \begin{bmatrix} (A+W) & -(A+W) & Akx \\ -(A+W) & (A+W) & -Akk \\ Akx^T & -Akk^T & 2k \end{bmatrix} \begin{Bmatrix} u_A \\ u_B \\ u_p \end{Bmatrix} \dots\dots(5)$$

where $A = kA_c^2 xx^T / V_c$; $W = pA(I - xx^T) / l$; $k = \gamma / V_c$; X , the direction cosine vector; A_c , the cylinder cross sectional area; V_c , hydraulic oil volume in the cylinder; γ , a coefficient for indicating flow direction; and p , the cylinder internal pressure. In equation (5), the integral of hydraulic fluid flow rate and the node displacement of the link system are coupled, making coupling analysis possible. Although the above equation expresses the balance on the head side, the balance on the rod side is expressed in a similar manner. Other factors, such as mass, proportional damping, stroke end stoppers and friction resistance, are also taken into consideration.

Other hydraulic elements are defined by basic equations and characteristics. The elements, such as element damping coefficient, are determined from relations in the incremental system as described above, and integrated into the dynamic equation of the total system by introducing the correction external force.

1.3.1 Piping element

In a three port element having three divisions, the relation between the pressure p at each node point and the integral of flow rate u is given by the equation (6), and the resulting element coefficient matrix gives the element stiffness matrix.

$$\begin{Bmatrix} P_1 \\ P_2 \\ P_3 \end{Bmatrix} = \frac{1}{V_0} \begin{bmatrix} 1^2 & 1 & 2 & 1 & 3 \\ 1 & 2 & 2^2 & 2 & 3 \\ 1 & 3 & 2 & 3 & 3^2 \end{bmatrix} \begin{Bmatrix} u_1 \\ u_2 \\ u_3 \end{Bmatrix} \dots\dots\dots(6)$$

where; V_0 , volume elastic modulus of hydraulic oil; u_i ,

coordinate transformation coefficients showing in-flow and out-flow at each port.

The pressure loss due to piping is defined as follows, using differential pressure p and flow rate q .

$$p = c_1 q^{1.75} + c_2 q^2 \dots\dots\dots(7)$$

where, the first term in the right member represents the pressure loss of a straight pipe and the second term represents pressure losses due to rapid expansion/reduction, bend, elbow and such. The term c_1 is a coefficient determined by the length and diameter of the straight pipe, while c_2 is a coefficient determined by other factors such as rapid expansion/reduction, bend and elbow.

1.3.2 Valve element

Each control valve is assumed to have a variable opening and the differential pressure at each metering valve is defined as follows.

$$P = \frac{1}{2(c_0 A_0)^2} q^2 \dots\dots\dots(8)$$

where; c_0 is a coefficient for flow; A_0 , full opening area; δ , valve opening; and ρ , hydraulic oil density. The valve opening at each port is a function of the valve stroke.

1.3.3 Check valve, Relief valve

Check valves for directional control and relief valves for pressure control are defined as damping elements, wherein the relation between the differential pressure p and flow rate q has piecewise-linear characteristics.

1.3.4 Hydraulic pump element

The hydraulic pump controls its pumping capacity variably with an operation lever and supplies pressurized oil to actuators. The motive power of engine rotation axis is converted into hydraulic power, and the relation between the motive power torque of the engine and the discharge pressure of the hydraulic pump is expressed by equation (9).

$$\begin{bmatrix} Tr \\ P \end{bmatrix} = \begin{bmatrix} 1 & 2 \\ 1 & 2 \end{bmatrix} \begin{bmatrix} u \\ u \end{bmatrix} \dots\dots\dots(9)$$

Where; θ , rotation angle of hydraulic pump; u , the integral of hydraulic fluid flow rate; Tr , output torque of the hydraulic pump; and P is the pump discharge pressure. The term $\begin{bmatrix} 1 & 2 \\ 1 & 2 \end{bmatrix}$ is a coordinate transformation coefficient, which enables coupling between the pump rotation system and the hydraulic flow system by assuming $\begin{bmatrix} 1 & 2 \\ 1 & 2 \end{bmatrix}$ being the transformation coefficient equivalent to the hydraulic pump capacity. By making $\begin{bmatrix} 1 & 2 \\ 1 & 2 \end{bmatrix}$ variable against time, pump capacity

control of actual pump operation is simulated. The volume efficiency of the hydraulic pump is modeled as an equivalent variable opening, and the torque losses of mechanics are modeled as non-linear damping elements to the rotational degree of freedom.

1.4 Analytic theory of engine

The engine is a diesel engine with an electronic governor. The electronic governor computes a rack position and the driving torque of the position from the signal of engine rotation control.

$$J_e \dot{\omega}_e = T_e(\omega_e, x_r) - T_l \dots\dots\dots(10)$$

where; J_e , engine inertia moment; $\dot{\omega}_e$, engine rotation speed; T_l , loaded torque; x_r , fuel injection amount; and the driving torque $T_e(\omega_e, x_r)$ is the engine output torque determined from the engine bench data. The fuel consumption is calculated from the engine rotation and fuel injection amount. Dynamic engine characteristics are approximated to the actual performance by setting a delay in the control logic of the fuel injection command.

2. The excavation work analysis of an excavator

Digging and 90° swing are operations, in which the machine performance is most well evaluated among other excavator operations. A dynamic analysis was carried out on these operations to evaluate the fuel consumption during the operations

2.1 Analytical model of an hydraulic excavator

The linkage model of an excavator is shown in Figure 2. The attachment of the hydraulic excavator comprises a boom, arm and bucket, which are connected by pins to the upper body. In addition, the upper main

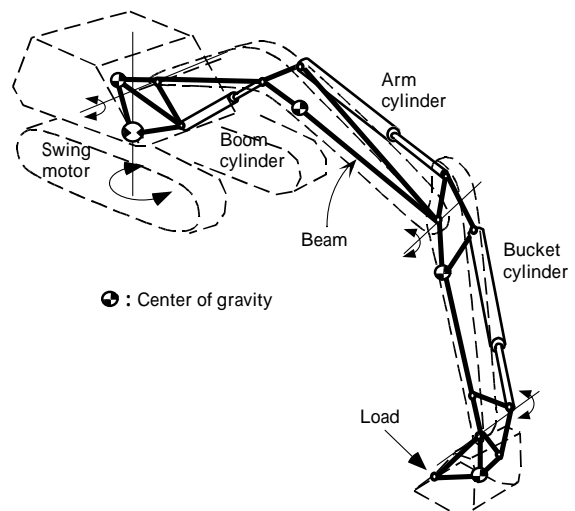

Fig. 2 Linkage model of hydraulic excavator

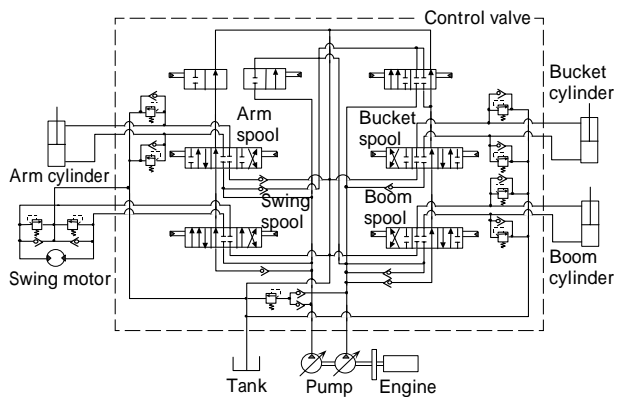

Fig. 3 Hydraulic system of hydraulic excavator

structure, along with the attachments, rotates by a hydraulic motor via a rotary bearing. Each portion of attachments is modeled using a large displacement beam element. The rotational degree of freedom at each pin joint is defined in each coordinate system of the member, which is treated independently from others. The weight of each element is treated as weight concentrated on its center of gravity.

Figure 3 shows the hydraulic system of the excavator. The hydraulic system has a hydraulic oils source with a pump driven by the engine. The flows to the cylinders and motors are controlled by levers which adjust the openings of hydraulic control valves. The pump has a variable capacity and controls its discharge amount depending on the load.

A dynamic motion analysis was carried out on actuators, using the input values of operation levers for the four actuators including the boom, arm, bucket and swing. In excavation, there are acting external forces such as reactive forces acted during excavation of soil and weight of the soil excavated in the bucket. The reactive forces acted during excavation are defined as viscosity resistances proportional to the bucket tip speed, while the weight of the soil is calculated based on the amount of the soil in the bucket depending on the bucket angle and bucket position against the ground.

2.2 Analytical result

Figure 4 shows a comparison between the values, actually measured for a digging and 90° swing operation, and the analytical results, verifying the accuracy of analyzed values. The upper graph shows the comparisons for the boom cylinder and arm cylinder displacements as actuator movement examples, the graph in the middle shows the comparison for the pump power and the bottom graph shows the comparison for the fuel consumption. All the graphs include two cycles of the digging and

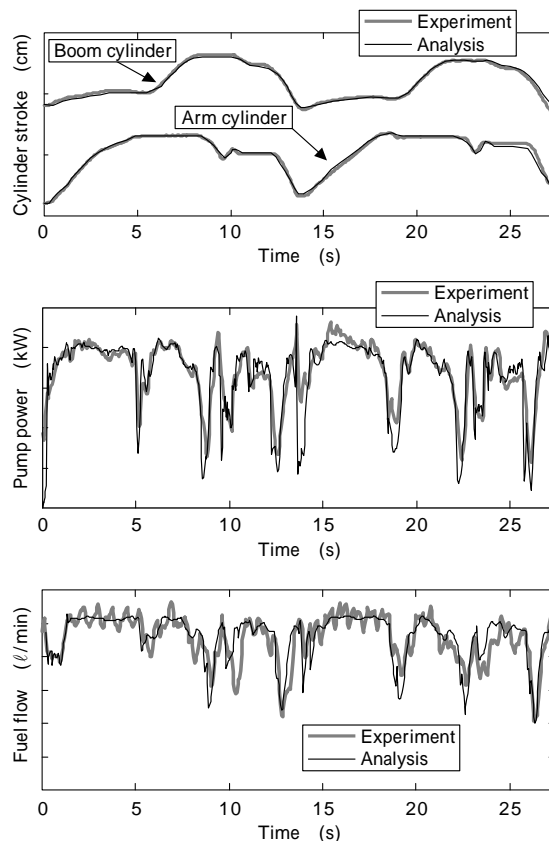

Fig. 4 Comparison of experiment and analysis concerning digging operation

90° swing operation.

The results verifies the validity of the analysis according to the above described approach, showing the simulated movements, pump power and fuel consumption matching well with the actual measurement, with errors of 2% or less for the pump power and fuel consumption. Thus, it is confirmed that individual characteristics of devices, such as hydraulic pump, control valves and piping, reflect the actual operation well.

3. Approach to energy saving

The above analysis provides not only macroscopic performance such as the fuel consumption and pump power, but also element forces (pressure losses) and passing flow rate for all the modeled elements. From those state variables, power loss for each element is calculated to determine detailed loss contributions. The following describes the energy saving technology to which the analysis is applied.

3.1 The loss contribution analysis

Figure 5 shows losses classified by elements, including the hydraulic system piping, valve opening and valve

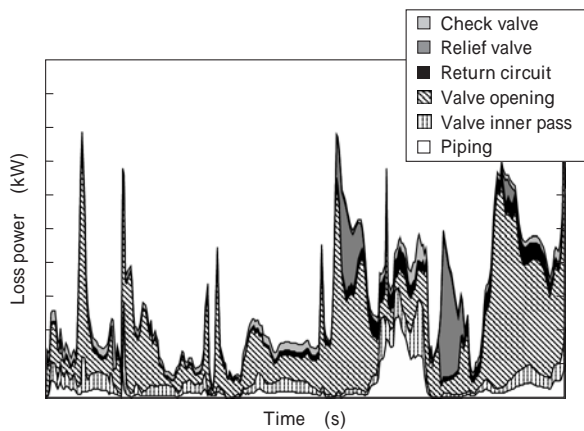

Fig. 5 Simulation result of loss power contribution

passage, as an example of loss contribution analysis. The element having the largest loss contribution is the control valve opening, followed by valve passage loss, piping loss and relief valve loss, the later three having almost the same contribution. The target loss reduction elements were extracted from the result.

3.2 Consideration on energy saving

The following procedure was taken for the energy saving.

- (a) Extraction of the energy loss to be reduced from all the energy loss including losses required for operation.
- (b) Setting of reduction target for each portion, considering the loss occurring at the portion.
- (c) Change of specifications to achieve the energy loss reduction, including control method for the valves and pump.
- (d) Verification on the quantitative effect of the above methods by analytical evaluation.
- (e) Verification of trouble-free operations other than the operations evaluated.
- (f) Calculation of cost and evaluation of cost performance of the energy saving before implementation.

The procedure (c) to (f) was repeated for each portion to determine the optimum specification.

Similar loss analysis was carried out separately on apparatuses, such as the hydraulic pump and engine. Frequently used conditions were determined for those apparatuses and the conditions were examined for their efficiency for the characteristics of the apparatuses. Efficiency improvements were implemented for the frequently used conditions.

3.3 Effect of the measures for energy saving

Figure 6 shows the simulation results of energy saving on items extracted as targets according to the above

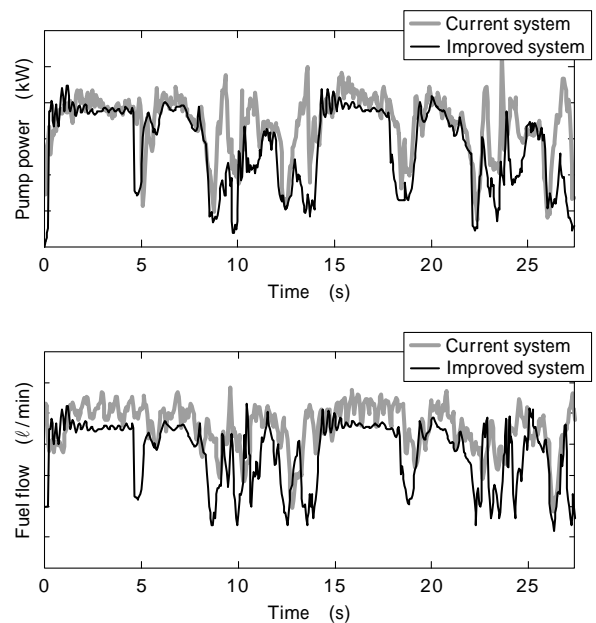

Fig. 6 Simulation result of improved energy-saving system

procedure. A remarkable reduction is observed in the pump power under operations with large losses. The fuel efficiency is improved significantly by the combined control of the engine and pump, both operating at high efficiencies.

The accumulated effect of consumed energy reduction was 20%. The actual machine, built later, performed as simulated, verifying the effectiveness of the approach for the development of various machines.

4. Development of the engine evaluation system

4.1 Preparation of the engine evaluation test bench

In order to satisfy both the emission regulations and energy saving, the fuel consumption evaluation and the matching evaluation of engine and hydraulic system are important. Because of this, an engine evaluation test bench, which can apply a load equivalent to actual engines, was prepared.

The test bench has the following features.

- (1) Any load applied to the engine can be reproduced repeatedly.
- (2) Responses to momentary loads on the engine can be evaluated.
- (3) The bench can be controlled by a shovel controller.

The engine dynamometer was the main focus in the development of the bench. Originally an engine dynamometer with a small inertia was considered. The dynamometer has recently become popular for the HILS of automobiles and trucks, however, it was found to be inapplicable because its fastest load input duration time was in the order of several hundred

ms, which is too slow for the evaluation of actual hydraulic load in the order of several to several tens ms. As a result, a load control configuration having a hydraulic pump and variable relief valve was selected. The variable relief valve for pressure control is an electromagnetic proportional valve, having a good response less than about 30 ms for 20 ton class.

4.2 Development of the engine HILS system

The test bench was evaluated in advance by applying loads set by simulations by SINDYS. In addition, we developed an engine HILS system, in which a real time simulation of lever input operation provides the engine the load corresponding to the simulation result, the simulation being the method for reproducing actual lever operations. **Figure 7** shows a conceptual diagram of the engine HILS system. The system comprises a control and measurement section and a simulation section, both of which communicate with each other in real time through PCs on the respective sections.

The system controls the pump and engine by providing commands to the shovel controller from the load pattern which is either simulated, or actually measured. The system also reproduces the actual load by providing pressure signals to the variable relief valve.

Even in the case that there is no load pattern, a dynamic performance evaluation of a power system, containing each engine operation, is made possible by the engine HILS system.

In addition, the above simulation system has an animation display which allows lever operations in accordance with the attachment movement.

Furthermore, the evaluation can be done by a shovel controller which allows checking of the controller programs and control parameters.

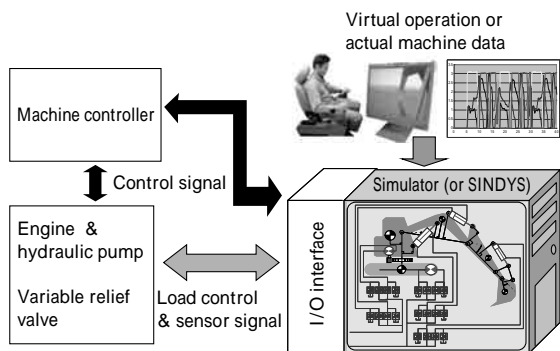

Fig. 7 Diagram of engine bench system

4.3 Bench evaluation of the engine

The engine evaluation test bench allows evaluation of energy saving effect of engine control methods and loss reductions based on simulated results, without using an actual hydraulic excavator.

The load analysis is done using the measurement data on the test bench based on the simulated load pattern. The resultant data are fed to the engine manufacturer to optimize the engine fuel consumption. The system allows quick confirmation on performance of Electronic Control Unit (ECU) with improved fuel efficiency made by the engine manufacturer and thus facilitate cooperation with the engine manufacturer to improve the fuel efficiency. **Figure 8** shows the progress in the engine development.

For engine control, a regulation control, which has been proven in conventional engines, was originally considered. However, a decision was made to apply an isochronous speed control (**Figure 9**), which can slightly reduce revolution, to further improve the fuel efficiency.

The isochronous control was evaluated for its energy saving effect from the power and fuel efficiency perspectives on the engine bench to confirm its advantages and disadvantages before the decision.

The series of simulation test indicated the possibility of achieving the energy saving target of 20%. The simulated results coincide well with the

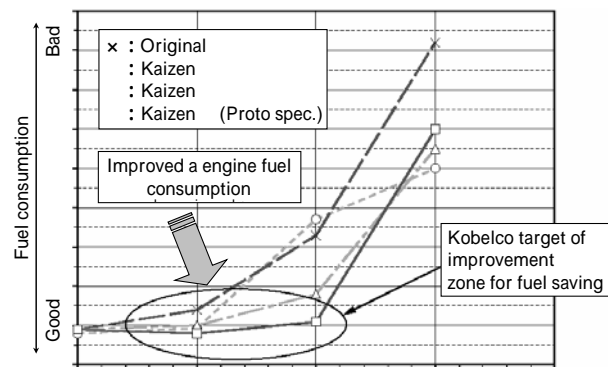

Fig. 8 Improvement progress of engine fuel consumption

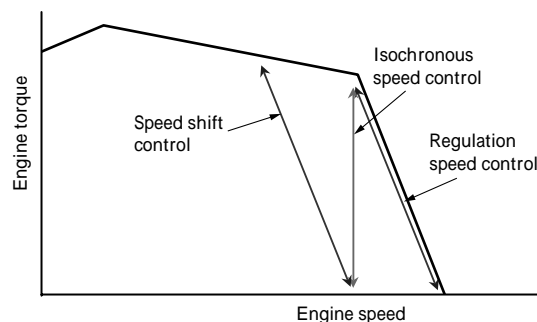

Fig. 9 Outline figure of engine speed control

actual fuel consumption data both qualitatively and quantitatively, verifying the validity of the test bench and load pattern.

5. Evaluation result of the actual machine

An experimental machine, with a modified hydraulic system, was built to evaluate performance and effect of the modification. Reduction of pressure loss, which has been the main focus from the beginning, was evaluated. The evaluation on the experimental machine achieved the substantial improvement of the workload.

In addition, adversities, such as incoherence in the control logic, were also confirmed by the experimental machine. Fuel consumption changing the control logic was fed back to the SINDYS sequentially to check each effect and the evaluation of energy saving was proceeded.

Operation property, a feature of our machine, was evaluated using the experimental machine to make sure that the increase of attachment speed, due to the reduction of pressure loss, will not give any adverse effect on the operation property. The result was reflected on the experimental machine to fine tune the operation property with minimum pressure loss.

The operation property was further improved on the experimental machine before evaluation of energy saving effect on an actual machine. The energy saving evaluation on the actual machine was based on the comparison with a current machine. Digging and 90° swing operations were evaluated.

The result indicates that 20% reduction of fuel consumption is achieved in energy saving mode (S mode) and 8% in heavy duty mode (H-mode), both satisfy the original targets. **Table 1** summarize energy saving effects of three machines (A, B and C). The results were summarized in the order of productivity (per a given fuel quantity).

The results indicate that the productivity is improved significantly for both the S mode and H mode compared to the current machine and the original targets have been achieved sufficiently. The achievement is sufficient enough for operators to actually feel the energy saving effect compared to the conventional machines.

Table 1 Actual machine measurement result (light and heavy duty)

Light duty digging		Productivity (m ³ /ℓ)	
		S mode	H mode
A	Actual measurement result	12.1	10.5
	Improvement vs. current machine	26%	9%
B	Actual measurement result	11.8	10.4
	Improvement vs. current machine	22%	7%
C	Actual measurement result	11.5	10.2
	Improvement vs. current machine	31%	16%

Heavy duty digging		Productivity (m ³ /ℓ)	
		S mode	H mode
A	Actual measurement result	6.0	6.3
	Improvement vs. current machine	11%	17%
B	Actual measurement result	7.0	6.6
	Improvement vs. current machine	43%	35%

Note) • Measured by digging with 90 degree swing
 • These results are not same in the case of actual use.

Conclusions

The non-linear dynamic analysis code SINDYS was effectively used for the evaluation of the energy efficiency in the hydraulic excavator power system. The result has lead to a measure to effectively reduce the energy consumption.

An engine evaluation system, capable of both the fuel efficiency evaluation and matching evaluation between engine and hydraulic system, was developed and was verified of its validity. The analytical technology was applied to the development of ACERA Geospec which successfully achieved energy saving of 20% (S-mode) and improvement of work load (H-mode)by 8%.

We will continue to work on energy saving technologies and contribute to the conservation of global environment.

References

- 1) T. Fujikawa et al., *R&D Kobe Steel Engineering Reports*, Vol.34, No.3, p.109 (1984).
- 2) E. Imanishi et al., *Proc. Adv. Mechatro.*, p.365 (1989).
- 3) E. Imanishi et al., *R&D Kobe Steel Engineering Reports*, Vol.48, No.2, p.14 (1998).
- 4) H. Zui et al., *Transacion of the Japan Society of Mechanical Engineers*, Vol.52, No.483, C, p.2814 (1986).
- 5) E. Imanishi et al., *Transacion of the Japan Society of Mechanical Engineers*, Vol.53, No.492, C, p.1171 (1987).