

Predicting Effect of Cold Rolling on Fatigue Strength under Combined Loading

Mariko MATSUDA*¹, Eiji OOTSUKI*², Shuhei KAJIHARA*³, Yoji HANAWA*⁴, Takeshi HAMADA*⁵

*¹Technical Development Department, Steel Casting & Forging Division, Iron & Steel Business

*²Forging Department, Steel Casting & Forging Plant, Steel Casting & Forging Division, Iron & Steel Business

*³Mitsui Engineering & Shipbuilding Co., Ltd.

*⁴Mechanical Engineering Research Laboratory, Technical Development Group

*⁵Mechanical Engineering Research Laboratory, Technical Development Group (currently with KOBELCO CRANES CO., LTD.)

The cold rolling method is adopted to improve the fatigue strength of crankpin fillet for marine diesel engines. Under working conditions, combined bending and torsional loading occurs in crankpin fillet; therefore, combined axial and torsional fatigue tests under tensile or compressive mean stress were conducted to distinguish among the three methods of fatigue strength evaluation. Modified IACS and Findley criteria were confirmed to be methods that are on the safe side. By evaluating fatigue strength by these criteria, it was confirmed that compressive residual stresses from the cold rolling method improve fatigue strength on the pin fillet surface of semi-built crankshafts under working conditions.

Introduction

Kobe Steel manufactures crankshafts for vessel diesel engines as one of the company's flagship products. In crankshafts, the fillets are subjected to maximum stress. Aiming at improving the fatigue strength of these parts, Kobe Steel developed a cold rolling technique. Not involving heating, this technique does not cause thermal deformation and is superior in dimensional accuracy and productivity. It was first adopted for a semi-built-up crankshaft made of cast steel in 1970 and has been adopted for some solid crankshafts since 1995. Nowadays, this technique has become one of the technologies making this company stand out among others.

Cold rolling is a method for improving the fatigue strength of the fillets by the combined effect of increased hardness caused by work hardening and compressive residual stress applied by cold rolling. Because hardness correlates well with fatigue strength, the effect of hardness increase can be predicted with relative ease. On the other hand, the effect of the compressive residual stress depends on the stress conditions of the fillets. The crankpin fillets are under a combined load of bending and torsion. Thus, in order to precisely evaluate the effect that the compressive residual stress applied by cold rolling has on the improvement of the fatigue strength, a new evaluation method must be developed, taking the combined loading into consideration.

The purpose of the present study is to make

predictable the improvement in fatigue strength that is an effect of the compressive residual stress applied by cold rolling. Fatigue tests were conducted under combined load conditions with mean stress. Three methodologies were selected from among the various conventional approaches that have been proposed for evaluating fatigue strength under combined loading. The three methodologies were evaluated for their validity. Furthermore, a new method for evaluating fatigue strength under combined load was adopted for the pin fillet of a semi-built-up crankshaft made of cast steel solely to estimate the effect of the compressive residual stress, applied by cold rolling, on fatigue strength.

1. Summary of conventional results

1.1 Evaluation by small-scale cold rolling test¹⁾

Fig. 1 depicts a small-scale cold-rolling test. Each specimen is made of a steel, "Throw Grade 3", which is one of the typical cast steel materials Kobe Steel uses for semi-built-up crankshafts. Table 1 shows the chemical composition and Table 2 shows the mechanical properties of the steel. A U-notched portion is provided on the $\phi 10$ mm specimen, and cold rolling was applied to the notched portion. The cold-rolled specimen was subjected to a rotary bending fatigue test. The results are shown in Fig. 2. In this figure, the horizontal axis represents "mean stress," while the vertical axis represents "fatigue strength."

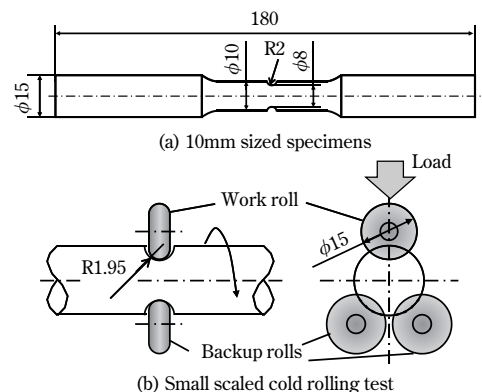

Fig. 1 Outline of small scaled cold rolling test using $\phi 10$ mm sized specimens

Table 1 Chemical composition of "Throw Grade3"

	C%	Si%	Mn%	Cr%	Mo%	Ni%	V%
Spec. "Throw Grade3"	0.25*	0.35*	1.0*	≤ 0.50	≤ 0.30	≤ 0.50	0.08*

*nominal

Table 2 Material property of "Throw Grade3"

Specimen	Tensile strength (MPa)	Yield point (MPa)	Elongation (%)	Reduction of area (%)
Spec. "Throw Grade3"	≥ 530	≥ 310	≥ 20	≥ 45

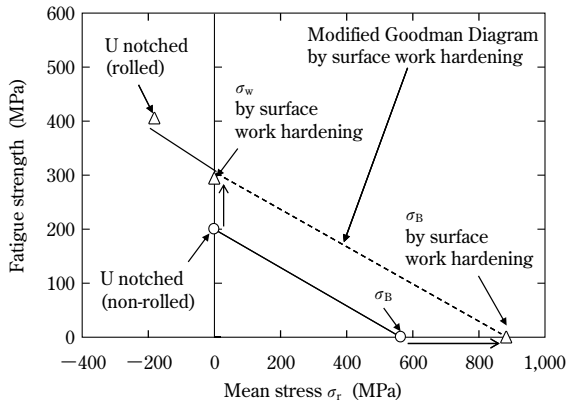

Fig. 2 Effects of surface work hardening and residual stress on fatigue strength of ϕ 10mm sized specimens after cold rolling

Also included in the figure is a Modified Goodman Diagram based on the fatigue strength, σ_w , and tensile strength, σ_B , which reflects an increase in hardness. The result indicates that, by regarding the compressive residual stress as the mean stress, the fatigue strength of the cold rolled specimen matches well with the Modified Goodman Diagram that accounts for the increase in hardness. It is concluded from the above that the main factors improving the fatigue strength of the steel, "Throw Grade 3", after cold rolling, are an increase in hardness caused by work hardening and compressive residual stress applied by cold rolling. It should also be noted that the compressive residual stress can be regarded as the mean stress.

1.2 Residual stress distribution in actual crankshafts²⁾

Kobe Steel produces large semi-built-up crankshafts, including K98MC with a cylinder diameter of 980mm. A real-scale throw was prepared using Throw Grade 3 steel, and residual stress was measured after cold rolling. Fig. 3 depicts the K98MC throw. The measurement points for residual stress are shown in Fig. 4 and the measurement results are shown in Fig. 5. As shown in Fig. 5, a compressive residual stress of about 400MPa is applied on the pin fillet

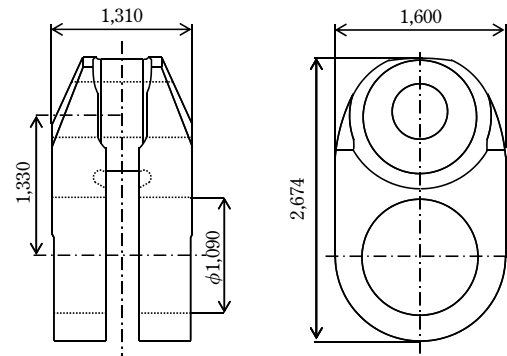

Fig. 3 Dimensions of K98MC throw

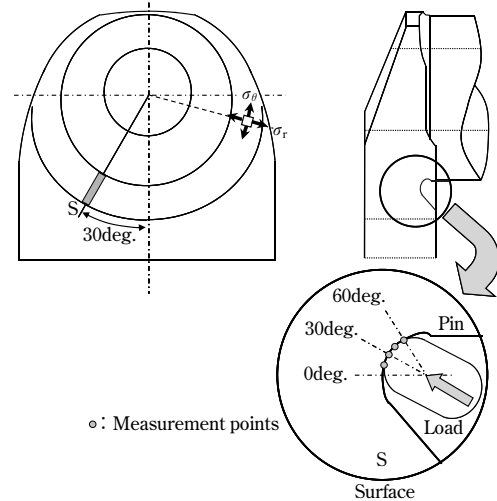

Fig. 4 Residual stress measurement points

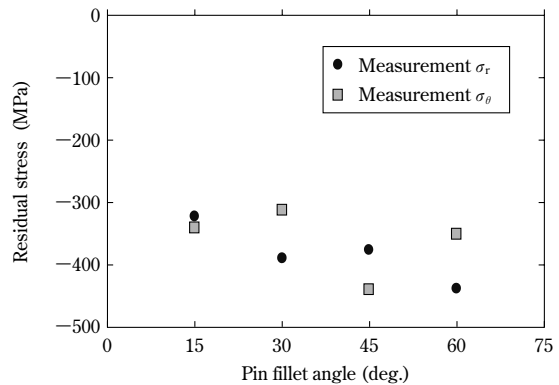

Fig. 5 Measured residual stresses on pin fillet surface

surface in both the radial and circumferential directions.

1.3 Methodologies for predicting fatigue strength considering combined loading

A unified rule of the International Association of Classification Societies for crankshafts for diesel engines (IACS UR M53, hereinafter simply referred to as "IACS rule")³⁾ adopts an evaluation formula that takes both bending and torsional stresses into account. However, it should be noted that the IACS

rule focuses only on the stress amplitude of varying stress and disregards the effect of mean stress. To resolve this issue, the present study adopts a method of modifying bending stress amplitude according to the modified Goodman diagram formula, as previously reported.²⁾ Formula (1) is the modified Goodman diagram formula, while Formula (2) is an evaluation formula including a partial modification of the IACS rule. The effect of mean stress on torsional stress is known to be negligible and thus is ignored.

$$\sigma_{ra} = \sigma_{ra} / \left[1 - \frac{\sigma_{rm}}{\sigma_B} \right] \dots\dots\dots (1)$$

$$\sqrt{\sigma_{ra}^2 + 3\tau_a^2} = \sigma_w \dots\dots\dots (2)$$

wherein

σ_{ra} is the amplitude of bending stress working on the fillet surface

σ_{rm} is the mean stress working on the fillet surface

τ_a is the amplitude of torsional stress working on the fillet surface

σ_B is the tensile strength of the material, and

σ_w is the axial load, or the rotary bending fatigue strength of the material

As a method for evaluating the fatigue strength under combined loading with a mean stress, Sines proposed Formula⁴⁾ based on Formula (3) introduced from the octahedral shear stress criterion,

$$\left. \begin{aligned} & \frac{1}{\sqrt{2}} \sqrt{(\sigma_{ax} - \sigma_{ay})^2 + (\sigma_{ay} - \sigma_{az})^2 + (\sigma_{az} - \sigma_{ax})^2 + 6(\tau_{axy}^2 + \tau_{ayz}^2 + \tau_{axz}^2)} \\ & = A - B(\sigma_{mx} + \sigma_{my} + \sigma_{mz}) \\ & A = \sigma_{w,R=-1}, B = \frac{\sigma_{w,R=-1}}{\sigma_{w,R=0}} - 1 \end{aligned} \right\} (3)$$

wherein

σ_{ai} ($i=x, y, z$) is the stress amplitude in x, y, z directions, respectively;

σ_{mi} ($i=x, y, z$) is the mean stress in x, y, z directions, respectively;

τ_{aij} ($i, j=x, y, z$) is the shear stress amplitude on x, y, z surfaces, respectively;

$\sigma_{w,R=-1}$ represents axial load fatigue strength under alternating load condition; and

$\sigma_{w,R=0}$ represents axial load fatigue strength under pulsating load condition.

As one of the methods for evaluating fatigue strength under conditions where phase differences exist in the combined loading, Findley used a critical plane approach to propose (Formula (4))⁵⁾. He postulates that fatigue life is controlled by a combination of alternating shear stress and maximum normal stress on a critical plane at an angle θ , which is determined by the condition that maximizes the left-hand side of Formula (4).

$$(\tau_\theta + k\sigma_\theta)_{\max} = f \dots\dots\dots (4)$$

wherein

τ_θ is the shear stress amplitude in the plane

inclined at an angle θ ; and

σ_θ is the normal stress amplitude in the plane inclined at an angle θ . It is to be noted that k, f are constants determined by the material and can be obtained from two fatigue strengths under different loads. The present study adopts Formula (5), which comprises fatigue strengths under alternating and pulsating axial loads.

$$\frac{\sigma_{w,R=0}}{\sigma_{w,R=-1}} = \frac{k + \sqrt{1+k^2}}{2k + \sqrt{1+4k^2}}, f = \frac{k + \sqrt{1+k^2}}{2} \sigma_{w,R=-1} \dots\dots (5)$$

This paper takes up the above three methods for evaluating fatigue strength under combined loading. These methods were adopted for the fatigue test results and used for evaluating an actual crankpin fillet. Hereafter, the evaluation method using Formula (1) and Formula (2) is referred to as "Modified IACS", the method using formula (3) is referred to as "Sines", and the one using Formula (4) and Formula (5) is referred to as "Findley".

2. Validity of methods for predicting fatigue strength based on fatigue test

2.1 Material and specimen

Axial load and torsional load were simultaneously applied in coordinate phase to each specimen made of "Throw Grade 3 steel" during the fatigue tests. Meanwhile, the material constants of three methods for evaluating fatigue strength were determined from fatigue strengths independently obtained with either an axial or torsional load respectively. Fig. 6 depicts the shape of the specimen used for the test.

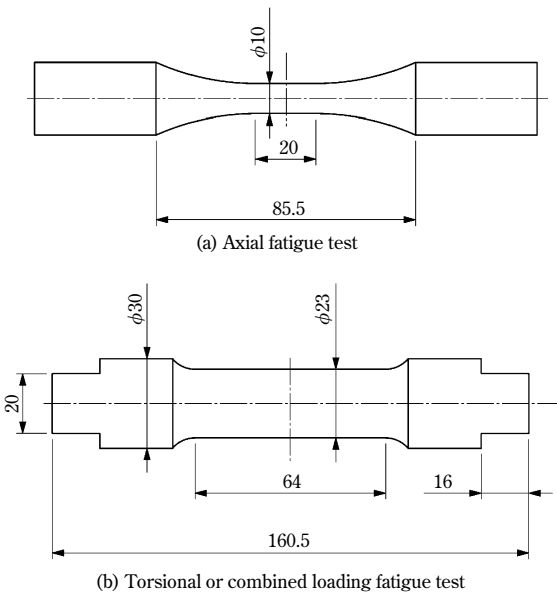

Fig. 6 Dimensions of fatigue test specimen

2.2 Testing conditions and results

Due to the limitation in the number of specimens, each fatigue test was started with a low load, and the load was increased step-by-step until failure. The number of cycles for a given loading condition was set to 3×10^6 cycles for fatigue tests under axial loading, and 1×10^6 cycles for the fatigue tests under torsional and combined loading.

In order to assess the effect of mean stress, axial load fatigue tests were conducted under two conditions of alternating and pulsating loading. The effect of mean stress on the torsional fatigue strength was regarded as negligible and, thus, the condition under which each torsional fatigue test was conducted did not include mean stress. The results of the axial loading and torsional fatigue tests are shown in Fig. 7. The axial load fatigue strengths for reversed and pulsating stresses agree well with the modified Goodman diagram.

The fatigue tests under combined loads were conducted under six conditions, as shown in Table 3. In each test, both axial-stress and torsional stress were applied simultaneously under three different levels of mean stress, i.e., "without mean stress (zero mean stress)," "with tensile mean stress" and "with compressive mean stress." The axial stress was applied in an alternating manner, while the torsional

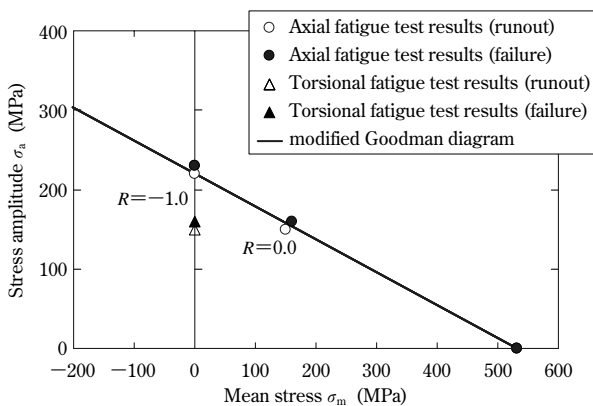

Fig. 7 Results of Axial and torsional fatigue test

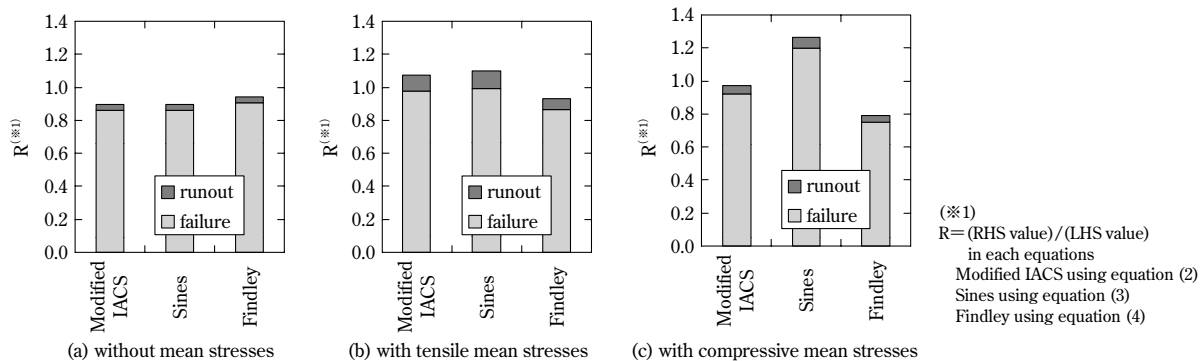

Fig. 8 Comparison of criteria under combined loading

stress was applied in a pulsating manner. In the condition with a compressive mean stress, a constant mean stress of -200MPa was applied axially to simulate the compressive residual stress applied by cold rolling. The results are summarized in Table 3.

2.3 Comparing methods for evaluating fatigue strength

The above three methods for fatigue strength evaluation were used to evaluate the results of the fatigue tests conducted under combined loading. Fig. 8 compares the evaluation results obtained by these methods. Each vertical axis represents the quotient of the value on the right-hand side divided by the value on the left, for the respective evaluation formulas. The value of the right-hand side was calculated using the stress amplitude for the fatigue test results in the uniaxial direction shown in Fig. 7. The right-hand value is intrinsic to the material, and the fatigue limit is provided by the condition where the value of the left-hand side matches that of the right.

An accurate fatigue strength evaluation requires the vertical axis value of Fig. 8 to be smaller than 1.0, at least for the case in which failure occurs. If the value of the vertical axis becomes smaller than 1.0 for a non-failure (run out) condition, the evaluation is regarded to be on the safe side. According to Fig. 8, all the methods yielded evaluation on the safe side

Table 3 Fatigue test results under combined loading

Axial-torsion fatigue tests	Axial stress		Torsional stress		Result
	Amplitude	Mean	Amplitude	Mean	
without mean stress	143.8	0.0	115.0	0.0	runout
	149.9	0.0	120.0	0.0	failure
with tensile mean stress	130.0	130.0	65.0	65.0	runout
	140.0	140.0	70.0	70.0	failure
with compressive mean stress	200.0	-200.0	100.0	100.0	runout
	210.0	-200.0	105.0	105.0	failure

for conditions of alternating and pulsating loading; however, for the conditions with compressive mean stress, "Sines" evaluation yielded a result significantly on the unsafe side. The "Modified IACS" and "Findley" methods yielded evaluations on the safe side regardless of the mean stress condition. The "Modified IACS" method yielded the most accurate result among the three.

3. Predicting effect of cold rolling on fillets

In a manner similar to that previously reported,²⁾ a MITSUI-MAN B&W 8K98MC-C engine was used for operational stress analysis to determine the stress generated on its pin fillet under working conditions. **Table 4** summarizes the data for the engine. **Fig. 9** shows the stress history of a pin-fillet with a fillet angle of 30 degrees (the angle as defined in Fig. 4). The pin-fillet was selected from the No.8 cylinder, since it is subjected to the maximum stress among all the fillets. The figure indicates that there is substantially no difference in the phase among the three stress components; and the stress, σ_θ , in the circumferential direction of the pin is smaller, in terms of both the stress amplitude and mean stress, compared with either the radial direction stress, σ_r , or the shear stress, τ .

The "Modified IACS" and "Findley" methods both yielded safe-side results as shown in Fig. 8 and were adopted for the evaluation of the stress generated on the pin fillet surface of the No.8 cylinder under working conditions. **Fig.10** shows the evaluation results for the fatigue strength of the pin fillet surface under combined loading. The effect of cold rolling has not been taken into account in this figure. The "Modified IACS" method cannot account for the stress, σ_θ , in the circumferential direction of the pin. Because of this, the "Findley" method was used to confirm the effect of the stress in the circumferential direction of the pin, and it was confirmed that the effect is negligible. Both the evaluations indicate that the stress currently generated is no greater than the fatigue limit. The "Findley" method yielded a result significantly more on the safe side than did the "Modified IACS."

Also confirmed was the effect of the compressive residual stress applied by cold rolling on the fatigue strength of the pin fillet surface. Either in Formula (2) of the "Modified IACS", or in Formula (4) of the "Findley," the permissible stress is determined by making the value of the right-hand side equal to that of the left-hand side, on the assumption that the stress conditions on the pin fillet surface were fixed. In this paper the stress condition on the pin fillet surface was set to a pulsating stress, and the ratio

Table 4 Particular of studied engine

Type		MITSUI-MAN B&W 8K98MC-C
Output	kW	45,680 (62,080HP)
MCR	rpm	104.0
Cylinder number		8
Cylinder bore	mm	980
Stroke	mm	2,400
Firing order		1-8-3-4-7-2-5-6
Throw material		Grade 3 (Cast steel)

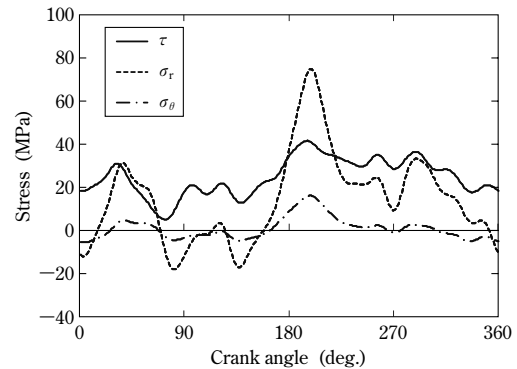
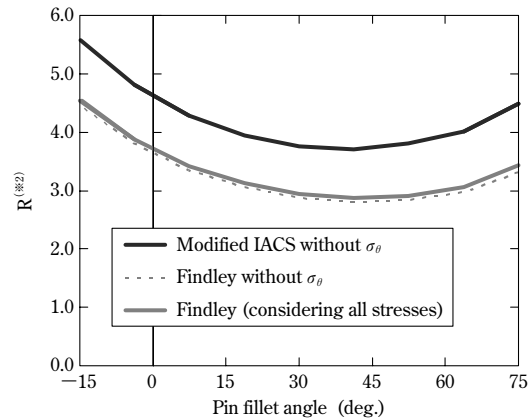

Fig. 9 Surface stress history of pin fillet (No.8cyl. pin fillet angle=30deg.)



(※2)
 $R = (\text{RHS value}) / (\text{LHS value})$ in each equations
 Modified IACS using equation (2)
 Findley using equation (4)

Fig.10 Evaluation of fatigue strength under combined loading of pin fillet (No.8cyl.)

between the bending stress and torsion stress was fixed at 1/2, which is same as in the case of the ratio of maximum stress under the working conditions shown in Fig. 9. The compressive residual stress applied by cold rolling was obtained from the actual measurements shown in Fig. 5. **Fig. 11** shows the permissible stresses for the pin fillet surface determined by the "Modified IACS" and "Findley" evaluations, as well as the way in which the permissible stresses were affected by the compressive residual stresses applied by cold rolling. This figure indicates that Findley's evaluation yields results

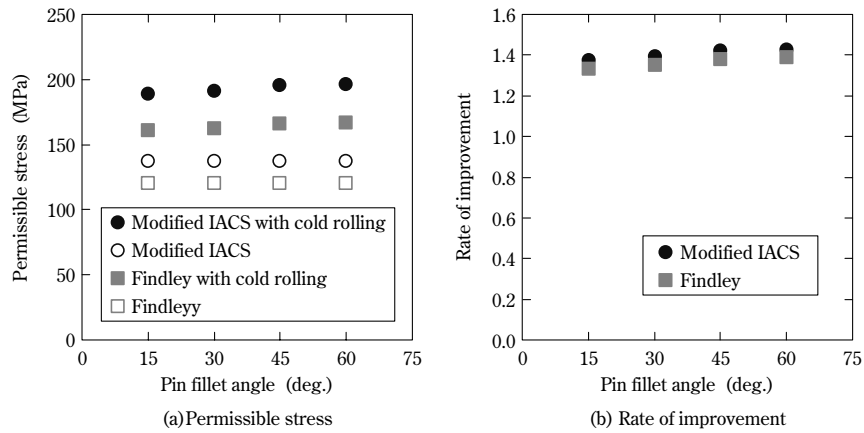

Fig.11 Rate of improvement of pin fillet permissible stress by cold rolling

more on the safe side than is the case with the Modified IACS; however, both methods evaluate the effect of the compressive residual stress on the permissible stress as being almost the same. It was also found that, on the pin fillet surface, the effect of the compressive residual stress applied by cold rolling improves the permissible stress by approximately 40%.

As reported in this paper, both the "Modified IACS" and "Findley" yield almost the same results for the evaluation of compressive residual stress applied by cold rolling on the fatigue strength of fillet surfaces. Findley's method makes it possible to account for all the stress components and phase differences; however, it requires repeated computation to determine the conditions that maximize the left-hand side of Formula (4). In the stress condition described in this paper, the stress in the circumferential direction of the pin can be regarded as negligible, and almost no phase difference exists. This has made accurate evaluation by the "Modified IACS" possible. The "Modified IACS" is a very convenient and effective evaluation method under stress conditions where only bending and torsion are combined, without a phase difference.

Conclusions

Fatigue tests were conducted under combined loading by regarding the effect of cold rolling as

mean stress. The validity of three methods for determining fatigue strength under combined loading was evaluated. As a result, it was found that the "Modified IACS" and "Findley" methods provide evaluation that is on the safe side, regardless of the mean stress. The "Modified IACS" has turned out to be a very convenient and effective evaluation method in cases where the combined stress consists only of bending and torsion without a phase difference.

This evaluation method was adopted for the pin fillet surface of an operating engine. It turned out that the compressive residual stress applied by cold rolling improves the permissible stress on the pin fillet surface by approximately 40%. This study does not account for the effect of work hardening caused by cold rolling. Thus, a more significant improvement in fatigue strength can be expected for a material having a greater work-hardening effect. The cold rolling technique has been implemented in practice and is expected to see more use in the future.

References

- 1) T. Hamada, et al., *Annual Spring Meeting (131st), Iron and Steel Institute of Japan*, p.394.
- 2) M. Matsuda et al., *R&D KOBE STEEL ENGINEERING REPORTS*, Vol. 59, No. 1 (2009), pp.89-93.
- 3) IACS UR M53, Calculation of Crankshafts for I. C. Engines.
- 4) G. Sines, *NACA Tech. Note*, 3495 (1955).
- 5) W. N. Findley, *J. Eng. Ind.*, Nov. (1959), pp.301-306.