

# A Multi-purpose Demolition Machine with Interchangeable Attachments

Koichiro NIWATA

Special Equipment Department, Global Engineering Center (GEC), KOBELCO CONSTRUCTION MACHINERY CO., LTD.

*A hydraulic excavator operates various actuators and uses them not only for digging, but also for various other jobs. Demolition of buildings is a typical application of an excavator. A variety of attachments have been developed for a wide working range from high to middle elevations as well as for foundations. Conventionally, however, it has been necessary to have an excavator for each specific attachment, and the users had to cover all costs to keep various excavators with different attachments. To solve such a problem, we have developed a series of multi-purpose demolition machines. Each machine has a main boom on which different kinds of attachments can be installed. This article includes descriptions and illustrations explaining the usefulness of the multi-purpose excavators that have been developed.*

## Introduction

Recent demolition sites in urban areas are more restricted in their passageways and spaces, which often causes difficulties in using large machines, or an increased number of machines, to shorten construction periods. Demolition jobs are conducted in various ways: some are conducted from the ground level and others from the rooftops of buildings. In the case of roof-mounted demolition, it may be difficult to bring in a large crane. In such a case, the limited lifting capacity allows only the use of smaller demolition machines. Thus, the work environment for demolition has become increasingly restricted.

On the other hand, an increasing number of demolition contractors are using rental equipment. Demolition machines are made with a variety of specifications. Owning various machines of different classes not only increases the need for parking space, but also leads to less utilization of the machines, decreasing the return on investment and causing a burden.

To solve these problems, we have developed multi-purpose demolition machines, as outlined in this paper.

## 1. Aims and features of multi-purpose demolition machines

KOBELCO CONSTRUCTION MACHINERY CO.,

LTD. has a line-up of demolition machines, including multi-purpose machines with special specifications (Fig. 1). A multi-purpose machine comprises a main body and a main boom attached to it; the main boom is adapted to receive several kinds of attachments. Fig. 2 is a conceptual diagram. The main boom has two pin-joints near its tip, which allows the mounting and dismounting of an attachment such as a separate boom and extra-long attachment. This multi-purpose demolition machine has one base machine and performs various tasks, which not only increases its utilization, but also decreases the initial purchase cost, as well as parking space and maintenance costs. Originally, multi-purpose machines were built mainly as large machines; however, the demand for smaller products has increased. Now, the multi-purpose concept has been extended to smaller machines, including small to mid-sized hydraulic excavators of the 13 to 26 tonne classes.



Fig. 1 Base machine of SK235SR

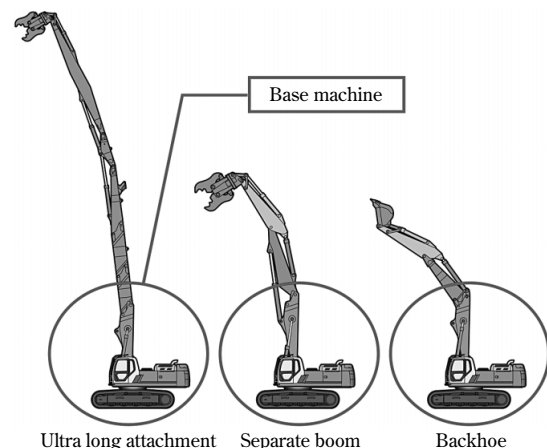

Fig. 2 Concept of machine with common use type main boom

## 2. Outline of attachments and their uses

The following describes two types of attachments, a short separate boom and an ultra-long attachment, both designed for a series of machines, from the SK135SR to the SK260DLC, which is introduced in this paper.

### 2.1 Separate boom

A separate boom has a jib cylinder at its mid-portion, which allows the boom to be bent and almost doubles the operating range compared with a conventional hydraulic excavator. The jib cylinder significantly increases the lifting capacity and enables the arm tip to be moved near the front edge of the crawler. This improves the efficiency of demolition work done near the crawlers. The separate boom secures the working range required for demolition work on lower stories and the foundation of a building. The attachments that can be interchangeably mounted at the boom tip include a crusher, breaker, rotary fork and bucket, enabling a variety of work. Also provided is a backhoe attachment for excavation application. The backhoe has the same shape as the one used for a general purpose hydraulic excavator. **Fig. 3** compares the operation range of the SK200DLC machine, which has a separate boom, with one having a conventional backhoe. **Fig. 4** shows the appearance of the SK260DLC with a separate boom.

### 2.2 Ultra-long attachments folded in two and three pieces

There are two specifications for ultra-long attachments; one is a two-piece type and the other is a three-piece type. The two-piece type is an ultra-long attachment with one joint in the arm. This attachment is light in mass and can easily be used in the same operating pattern as a backhoe. **Fig. 5**

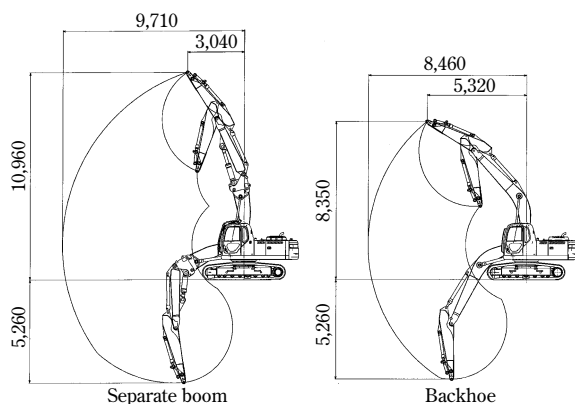

Fig. 3 Operation range comparison of SK200DLC

shows a SK235SRDLC with a two-piece ultra-long attachment. The machine has a maximum working height of 13.68m and can demolish buildings up to four stories high.

The other type, a three-piece ultra-long attachment, is capable of extending the working range by actuating the inter boom at the mid portion. The SK260DLC, shown in **Fig. 6**, has a maximum working height of 16.5m and can be used for demolishing jobs up to five stories high.



Fig. 4 Separate boom machine of SK260DLC



Fig. 5 2 piece ultra long machine of SK235SRDLC

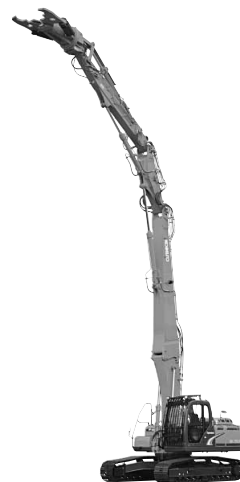

Fig. 6 3 piece ultra long machine of SK260DLC

### 3. General configurations

Fig. 7 shows the general configurations of the machines with main booms. The SK135SRDLC and SK235SRDLC are designed with a base machine having small rear swing and can work in narrow places without the necessity of paying undue attention to the rear. The largest machine of the series, the SK260DLC, with its main boom installed, but without an attachment, has a total length of 6.27m and a mass of 24.3 tonnes. This has enabled its transportation on a general purpose trailer.

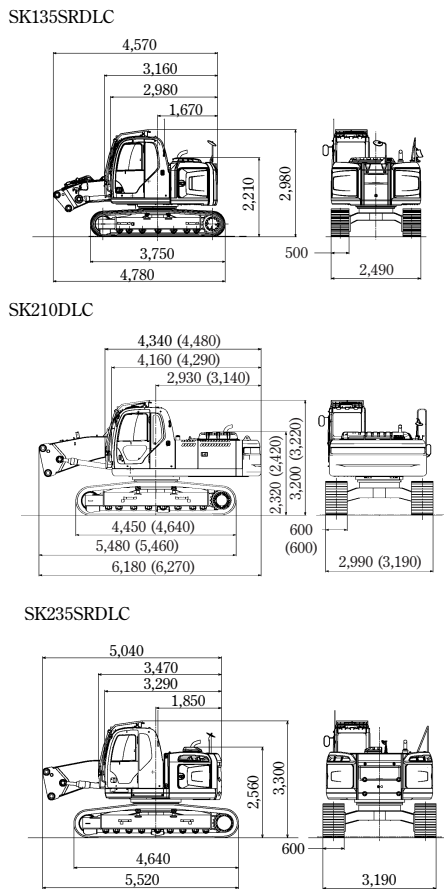

Fig. 7 General configuration

### 4. Attachment line-up

Table 1 summarizes the attachments designed for each model. A multi-purpose demolition machine can be used with more than one attachment, which adds value to the machine. The newly designed attachments are used with models of different classes and performance, and work at various demolition sites where buildings and foundations are demolished and debris is carried. Fig. 8 shows an example of attachment combinations for the SK235SRDLC.

When developing the new models, attachments

Table 1 Attachment line up for each model

	SK135SR	SK235SR	SK210DLC	SK260DLC
Back hoe	○			
Separate	○	○	○	○
2 piece ultra long	○	○	○	○
3 piece ultra long		○	○	○

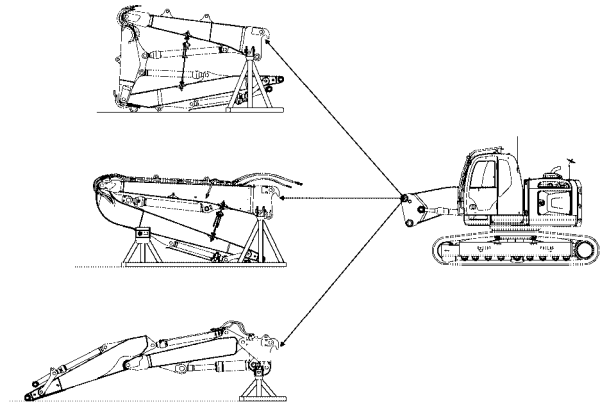

Fig. 8 Variation of attachment

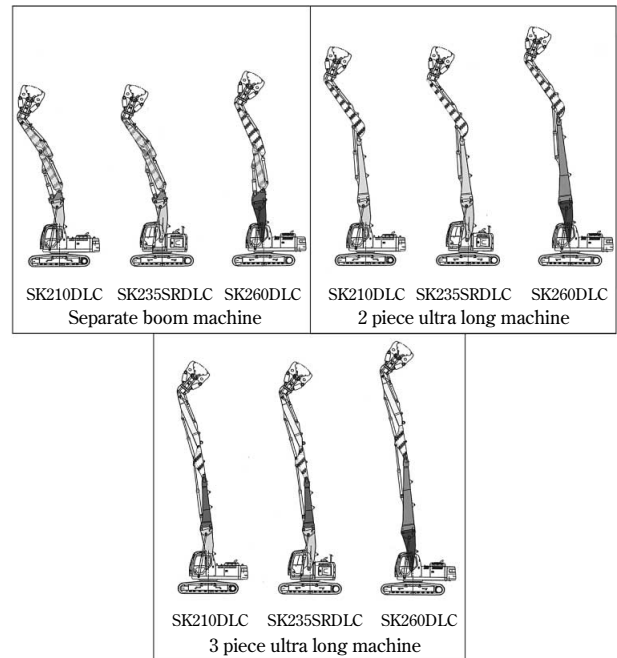

Fig. 9 Combination of attachment parts

are designed to be shared by more than one machine, which has significantly increased development efficiency. More specifically, the attachments for three models, the SK210DLC, SK235SRDLC and SK260DLC, all based on a medium-sized hydraulic excavator, use the same parts as shown in Fig. 9. In this figure, the parts of a pattern are interchangeable. The interchangeability of parts permitted by the new

development has evolved 9 variations (3 models, 3 specifications) and has added 4 variations to the product line.

## 5. Mounting and dismounting of attachments

To improve work efficiency at demolition sites, different attachments must be used interchangeably. When mounting an attachment, the hooks on the front boom are engaged on the positioning bars on the tip of the main boom. This facilitates the positioning of the connection pin-holes located at 2 positions, top and bottom, at the tip of the main boom (Fig.10). More specifically, the main body is driven close to the attachment, and the boom cylinder on the main boom is raised to engage the positioning bar with the hook. The attachment is turned around the hook until the positions of the two pin-holes align.

A conventional separate boom has a number of parts, such as pins and hydraulic cylinder hoses, which must be mounted or dismantled, making the work of mounting and dismantling time-consuming. The multi-purpose demolition machine developed this time comprises a structure called a "main boom front", having connecting portions for cylinders. This structure is placed between the main boom and front boom such that the structure and the front boom can be disassembled as a unit (Fig.11), which has significantly facilitated the mounting and dismantling of the separate boom.

A setting stand (Fig.12) enables mounting and dismantling without using a crane and ensures safety. Stop valves are provided at pipe joints to minimize the spillage of hydraulic oil when connecting or disconnecting pipes.

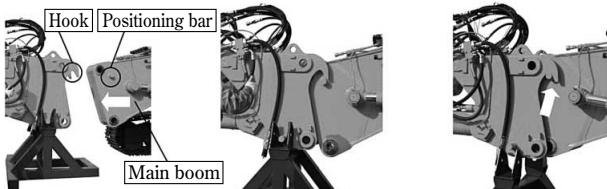

Fig.10 Procedure of attachment assembly

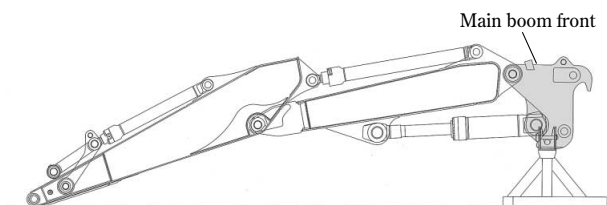

Fig.11 Main boom front

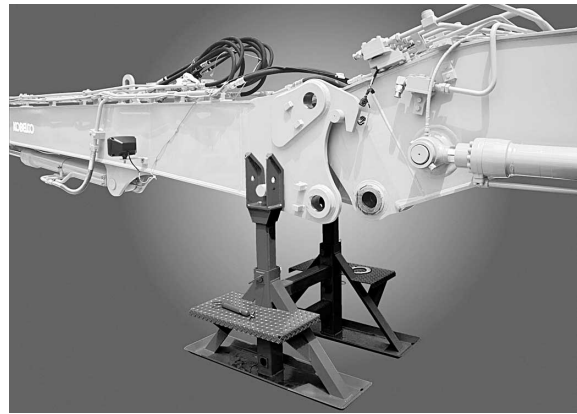

Fig.12 Setting stand of attachment

## 6. Safety apparatus

Each machine is well considered to ensure safety during demolition work. The machine with an ultra-long attachment is equipped with a warning apparatus that notifies the operator of the risk of turning over. The apparatus includes angle sensors placed at the joints of each attachment and triggers a buzzer when stability drops to a predetermined level. To prevent the window glass from being broken by falling objects and debris, the cab is protected by grating guards on three faces (Fig.13). In addition, an apparatus is provided for preventing an attachment from interfering with the cab, in consideration of the possibility that, in certain positions, an attachment at the boom tip may interfere with the cab. This safety apparatus, provided as a standard feature, triggers a buzzer when a crusher at the tip of the arm enters the region less than one meter from the front edge of the cab. Fig.14 shows the concept of the cab interference prevention apparatus. Other safety features include a fall prevention valve for the boom, rearview camera and travel alarms.



Fig.13 Appearance of demolition cabin



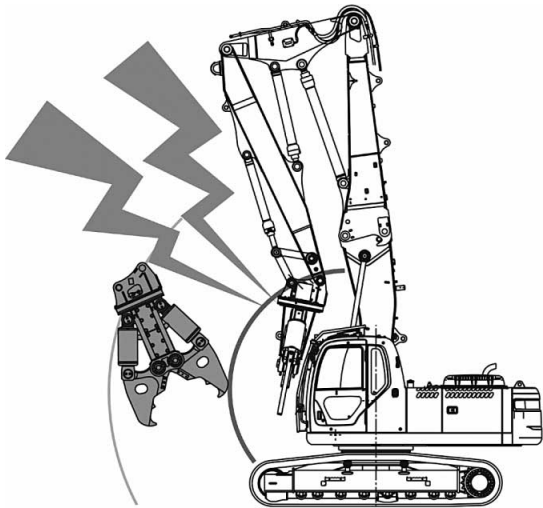

Fig.14 Cab interference prevention system

## 7. Application examples

The multi-purpose demolition machines introduced in this paper have been commercialized and are being widely used at actual demolition sites. Fig.15 shows a SK135SRDLC separate boom machine working at a demolition site. Fig.16 shows a SK235SRDLC with a two-piece ultra-long attachment.

These machines, designed for multi-purpose demolition, have an increasing number of variations in order to respond to the requirements of transportability and workability in addition to their demolition performance. The following are some examples of their applications.

A long reach attachment machine, having an attachment with extended length, is characterized by its wide working range and is used not only for demolition, but also for the dredging of rivers and field maintenance. Such a machine, however, has a disadvantage in its transportability. The SK260LC separate-type long reach machine (Fig.17) is based



Fig.15 SK135SRDLC separate boom attachment machine



Fig.16 SK235SRDLC 2 piece ultra long attachment machine



Fig.17 SK260LC separated type long reach machine



Fig.18 SK260LC long reach in separation

on the separate boom of the multi-purpose demolition machines and has significantly improved transportability. Fig.18 shows the machine after the attachment has been separated from it.

## Conclusions

Hydraulic excavators are primarily characterized by their ability to work with a number of actuators and they have the advantage of being able to use a variety of attachments. The multi-purpose demolition machines have mechanisms to further exploit such advantages. The machines are currently used mainly for construction work involving demolition, and their application range is expected to grow in the future.