

Reducing Weight and Width of Latticed Boom Crawler Cranes

Tepei MAEDO*¹, Yasuo ICHIKAWA*¹, Yutaka KOBAYASHI*², Eiji MIYA*², Takunori YAMAGUCHI*³, Hiromitsu HAMAGUCHI*³

*¹ Engineering & Development Div., System & Component Development Dept., KOBELCO CRANES CO., LTD.

*² Engineering & Development Div., Crane Engineering Dept., KOBELCO CRANES CO., LTD.

*³ Mechanical Engineering Research Laboratory, Technical Development Group

Reduction of the transportation width to less than 3m and the transportation weight to less than 32 tonnes in Japan (45 tonnes overseas) have been achieved for latticed boom crawler cranes (LBCCs) of the 110 tonne and 250 tonne classes. The lifting weights of the 110 tonne and 250 tonne class cranes are comparable with those of our cranes already on the market. One of the important factors in this achievement is the weight reduction of the boom without sacrificing their lifting capacity. To this end, structural analyses of the booms have been performed using finite-element simulations, and their operational ability has been verified by a newly produced general-purpose LBCC.

Introduction

Latticed boom crawler cranes (hereinafter referred to as "LBCCs") are the flagship products of KOBELCO CRANES CO., LTD. The company has one of the largest market shares in the world. The high rate of the yen and the rise of Chinese manufacturers in recent years, however, have made the competition more intense for general purpose LBCCs with lifting capacities no greater than 250 tonnes. Against this background, and to ensure its position as a top runner with outstanding technology, the company has newly developed and launched twenty-one types of general-purpose LBCCs. This market release was backed by new emission regulations, such as Interim Tier 4 (North America) and Stage III B (Europe), enacted in 2011.

The development of the new cranes was based on three product concepts: namely, ensuring safe and secure work anywhere in the world (meeting all the regulations for environment, transportation and safety), enabling efficient work and safety management (improved transportability, low energy consumption, work history management and optimized structure), and allowing efficient maintenance (preventive maintenance based on the work and maintenance history).

Among these product concepts, developing a structure with improved transportability has turned out to be of particular importance. Generally, when an LBCC is to be transported, its main body is disassembled and loaded onto a trailer. However, different countries have different regulations for the

mass and width (transportation width) of the load that a trailer can carry. Besides this, construction projects are often planned at narrow sites, for example in European cities, where the location calls for a machine that can be disassembled into a narrower width for transportation.

Therefore, there has been a need to remodel conventional machines to further decrease the transportation widths of their main bodies and to reduce their weights down to a level that meets transportation regulations.

This paper describes crane structures with special focus on their weight reduction.

1. Development goals

Table 1 compares the transportability of 110 tonne class LBCCs, including the current model and a new model (one example), as well as two machines built by other companies.

The newly-developed general-purpose LBCC is designed to meet the following requirements for

Table 1 Comparison of transportabilities among the current model, new model, and other companies' cranes (Overseas model of the 110 tonne class)

| | KOBELCO | | Company L | Company T |
|------------------------------|---------------|-----------|-----------|-----------|
| | Current model | New model | | |
| Weight of transportation (t) | 40.7 | 36.4 | 36.7 | 37.0 |
| Width of transportation (m) | 3.2 | 2.99 | 3.5 | 3.6 |

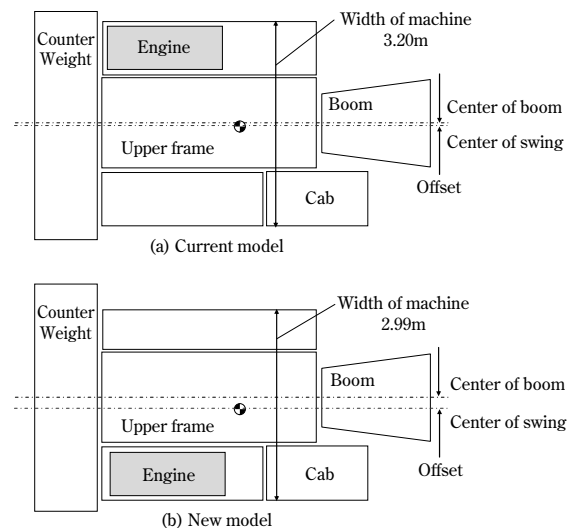

Fig. 1 Comparison of machine width in current and new models

transportation after disassembly:

- Transportation width: 2.99m or less (**Fig. 1**)
- Transportation mass: 32 tonnes or less (Japanese model), 45 tonnes or less (overseas model)

The new machine is designed to have a lifting capacity comparable with that of conventional machines.

2. LBCC structure

As shown in **Fig. 2**, an LBCC has an upper body, a car body and a lower body. The upper body includes

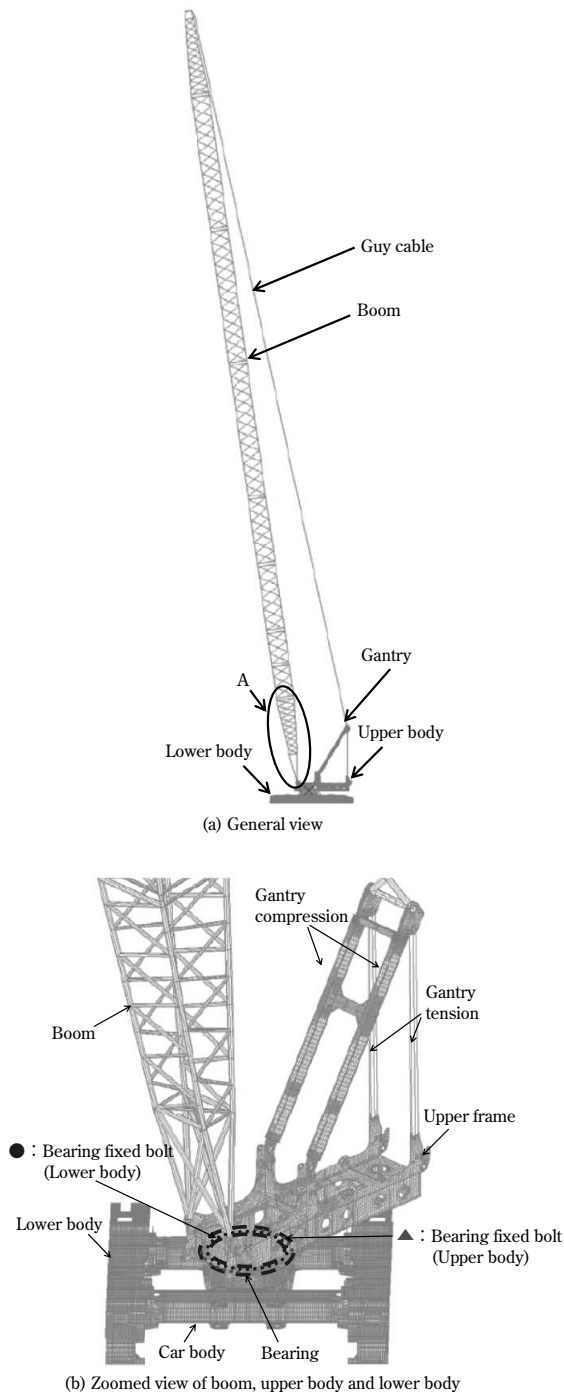

Fig. 2 FEM model of LBCC (110 tonne class)

a slewing frame and a gantry, in which the slewing frame carries major components such as a boom, cab and engine. The car body is connected to the slewing frame via a slewing bearing. The lower body is connected to the car body and is equipped with a pair of crawlers that touch the ground. These upper and lower bodies are the critical elements in the structural design.

3. Weight reduction of the structure

As shown in the comparison in **Fig. 1**, the structure with a transportation width of no greater than 2.99m has an offset, or distance between the boom's center and slewing center, greater than that of the conventional structure. This causes an offset load to be exerted on the main body. Reducing the structural weight to meet the transport regulations of various countries may decrease the structural stiffness. This reduction also increases the deflection of the boom as well as the axial force exerted on the screw bolts that fasten the slewing bearing, posing a problem.

The primary structural requirements for an LBCC are strength and stiffness for lifting operations. In the current development, the cross sectional areas are secured to the greatest degree possible within the limitations of the transportation performance set as a development goal. A finite element method analysis was performed to optimize and determine the structure and shapes. For example, in the case of the 110 tonne class LBCC, in which the determinant for strength is the maximum side-ways deflection of the boom, the aim was to reduce the total mass of the lower boom portion, slewing frame and car body by about 3.1 tonnes, as compared with the conventional model, to achieve the transportability goal. In the case of the 250 tonne class LBCC, on the other hand, the determinant for strength is the maximum axial force, which is exerted on the screw bolts that fasten the slewing bearing and is caused by an inhomogeneous stiffness distribution in the main body. To achieve transportability for this model, the goal was to reduce the total mass of the slewing frame and car body by about 0.7 tonnes, as compared with the conventional model. The following describes the details of the weight reduction achieved for these two models, the 110 tonne class and 250 tonne class LBCCs.

3.1 Analysis model

Fig. 2 shows a finite element method (FEM) model of an LBCC. In this model, the slewing frame, car body, crawler, gantry compression member, guy

cables and slewing bearing are regarded as "shell elements"; the attachment is regarded as a "beam element"; and the gantry tension member is regarded as a "truss element". The upper body and lower body are connected by a "beam element" or by a "rigid element" at the axial center of each screw bolt fixing the slewing bearing.

Analyzing the entire structure of an LBCC, as described above, allows evaluation of the stiffness and deformation, not only of the subject part, but also of other relevant structural parts, unlike a case in which each structural part is independently analyzed. This enables the analysis of the areas adjacent to joints, such as the screw bolts fixing the slewing bearing, without much deviation from the actual measurements, offering a tool for studying reinforcement with minimum mass.

The load conditions for the 110 tonne class LBCC were set so as to include a boom length of 70.1m (fully extended), the boom length that maximizes the sideways deflection, a working radius of 12.0m and a lifting load of 19.6 tonnes. On the other hand, the load conditions for the 250 tonne class LBCC include a boom length of 15.2m (fully contracted), the boom length that maximizes the moment load exerted on the slewing bearing, a working radius of 10.0 m and a lifting load of 117 tonnes.

3.2 Weight reduction

3.2.1 Weight reduction of 110 tonne class LBCC

A preliminary verification performed on a 110 tonne class LBCC, using an FEM model (Fig. 2), revealed that the lack of stiffness increases the deflection of the boom to close to the allowable limit when lifting a load. Reinforcement was considered such that the weight would stay within the reduction target. The lower boom portion (designated as "A" in Fig. 2(a)) and a portion of the slewing frame shown in Fig. 2(b), the portion at which the boom is attached, were examined. The details are as follows.

1) Reinforcement of boom and slewing frame

A boom has a lattice structure consisting of pipes and is separated into upper, middle and lower parts, in which each part is connected to the adjacent part by pins. The load exerted at the tip of the boom is transmitted, via guy cables that support the boom, to the slewing frame and to the lower body. As shown in Table 2, verification using the FEM model has revealed that reinforcing the lower body has only a small effect on the sideways deflection of the boom. The sideways deflection of the boom is found to be more effectively decreased

by increasing the outer diameter and the wall thickness of the main pipes of the lower boom (portion A in Fig. 2(a)). Reinforcing the slewing frame in and around the area where the boom is attached (Fig. 3) is also effective against sideways deflection. Reinforcement measures suggested by the preliminary verification were implemented in an actual machine. The deflection at the tip of the boom was measured and found to be 14% smaller than it was before the reinforcement, and it is well below the allowable limit (Fig. 4).

2) Weight reduction for 110 tonne class LBCC

As a result of the above study, the total of the masses of the lower boom portion, slewing frame and car body has been decreased by about 3.1 tonnes, as compared with the conventional machine.

Table 2 Effect of boom, upper body and lower body reinforcement

| Part of reinforcement | Reduction of displacement to mass of reinforcement |
|-----------------------|--|
| Boom | ▲1.54mm/kg |
| Upper body | ▲0.78mm/kg |
| Lower body | ▲0.17mm/kg |

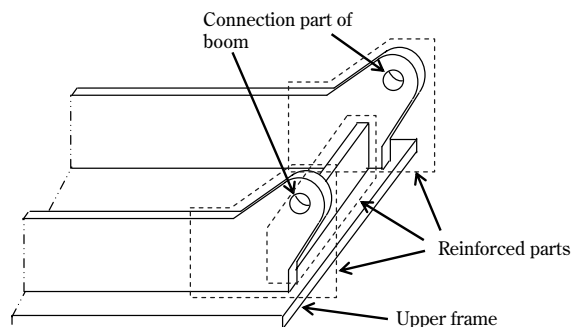

Fig. 3 Reinforced parts of upper frame

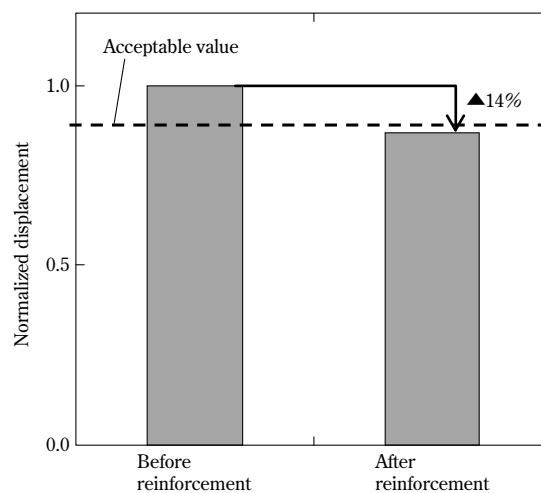

Fig. 4 Effect of reinforcement

3.2.2 Weight reduction of 250 tonne class LBCC

Fig. 5(a) depicts an FEM model of a 250 tonne class LBCC. A preliminary study was conducted using this FEM model. The results show that the increased offset and decreased weight of the main body together have increased the axial force exerted on the screw bolts that fasten the slewing bearing almost to the permissible limit. Thus, reinforcement was considered such that the weight stays within the reduction target. A pair of annular portions on the upper body, to which one side of the slewing bearing is attached (Fig. 5(b), hereinafter collectively referred to as "portion B"), were examined, as were a pair of annular portions on the lower body to which the other side of the slewing bearing is attached (Fig. 5(c), hereinafter collectively referred to as "portion C"). Reinforcement methods were studied for these portions.

1) Reinforcement of portion B

Portion B includes a slewing frame and a slewing bearing, which are held together by screw bolts. As shown in Fig 5(a), the load of lifting is transmitted to the slewing frame, slewing bearing and the lower body via a boom, guy cables that support the boom, a mast, a hoist rope and a gantry. Each portion to which the slewing bearing is attached is subject to a moment load exerted by gantry tension members. This moment load varies from point to point because

it is affected by the offset between the centers of the boom and slewing bearing and also by the distances between the points and the tension members. Due to the offset, portion "D" in Fig. 6 is subject to a higher moment load around the y-axis, as compared with portion "E". Portion "D" is also subject to a higher moment load around the x-axis because it is located farther away from the gantry tension member. In addition, the screw bolts in and around portion-D are subject to a greater axial force because a side plate of the slewing frame increases the local stiffness.

Accounting for the above, the FEM model shown in Fig. 5(a) was used for a preliminary study of the axial force exerted on the screw bolts. The result indicates that reinforcing portion F in Fig. 6 decreases the axial force exerted on the screw bolts in and around portion D. Reinforcement of portion F is considered to have leveled out the uneven stiffness in and around portion D.

2) Reinforcement of portion C

In the lower body depicted in Fig. 7, portion G exhibits a stiffness higher than the periphery because this portion is reinforced by an annular ring and side plate. On the other hand, portion G is subject to the moment and thrust load transmitted from the boom and upper body via the slewing bearing. This causes a large axial force to be exerted on the screw bolts that fasten the slewing bearing in and around portion G.

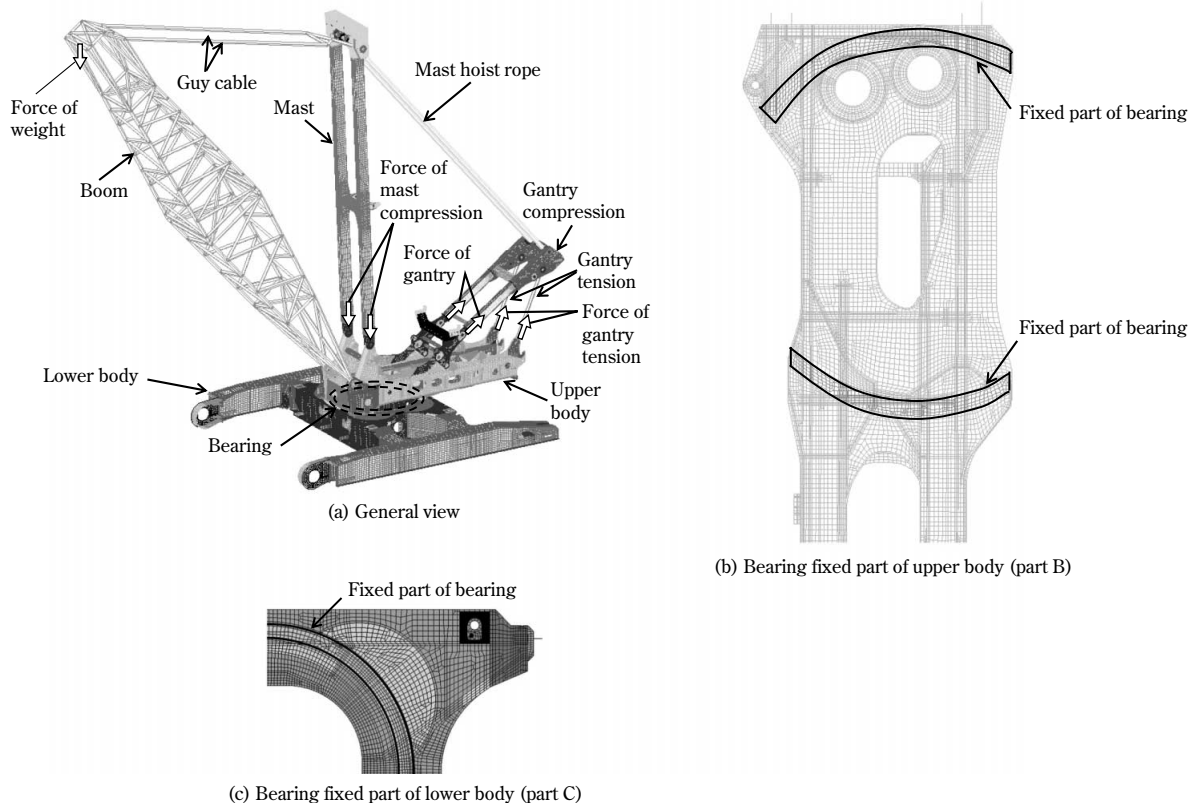

Fig. 5 FEM model of LBCC (250 tonne class)

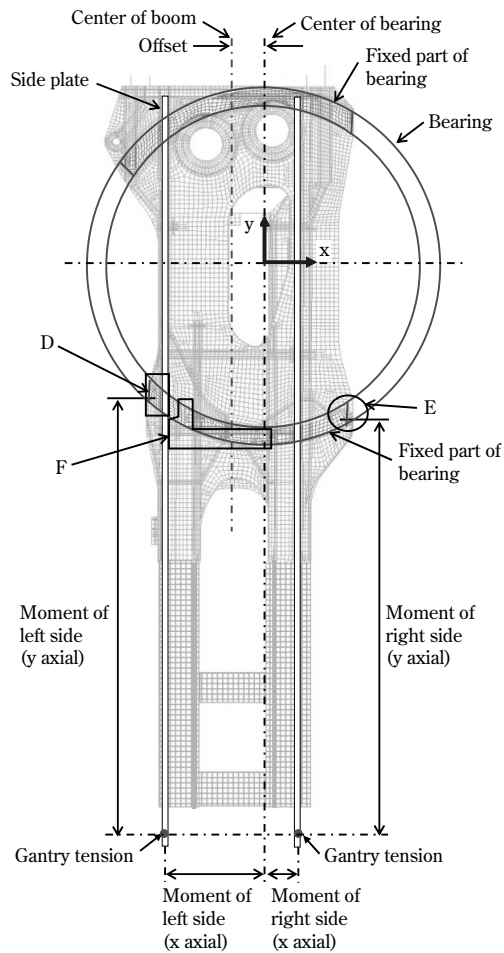

Fig. 6 Reinforcement of bearing fixed part

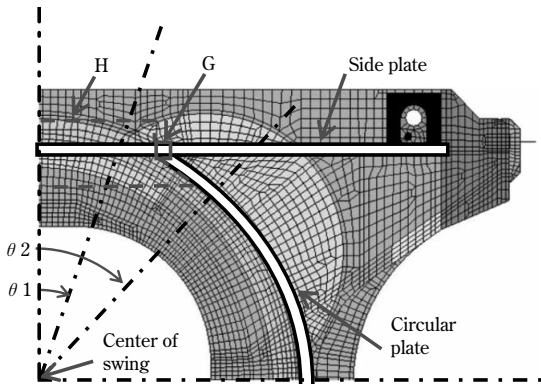

Fig. 7 Reinforcement of lower body

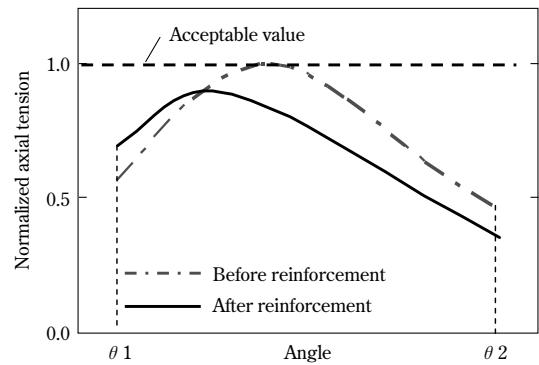

Fig. 8 Bolt axial tension reduction achieved by reinforcement

An FEM analysis was conducted to account for the above. The result indicates that reinforcement of portion H in Fig. 7 levels out the uneven stiffness in and around portion G, decreasing the axial force exerted on the screw bolts. The reinforcement of portion H based on this result, as well as the reinforcement of portion F, as described in section (1), have decreased the axial force exerted on the screw bolts to a point below the allowable limit (Fig. 8).

3) Weight reduction of 250 tonne class LBCC

As a result of the above study, the total mass of the slewing frame and car body of the 250 tonne class LBCC has been decreased by approximately 0.7 tonnes, as compared with the conventional machine.

Conclusions

The method of reducing the weight and simultaneously securing the stiffness of a general-purpose LBCC of 250 tonne class or smaller is described. The technique for analyzing an entire body, as introduced in this paper, is a versatile approach and is adaptable to LBCCs larger than the 250 tonne class. Such an LBCC has a longer boom, as well as larger upper and lower bodies, and can exhibit larger deformations. We will strive to reduce the weight and to optimize the stiffness of other machines by adopting a similar approach.