

Development of Steel Castings and Forgings for Vessels

Nobuyuki FUJITSUNA

Technical Development Dept., Steel Casting & Forging Div., Iron & Steel Business

KOBE STEEL has been developing crankshafts, as well as other steel castings and forgings for ships, to make ships more energy efficient and reliable. This paper introduces technologies relevant to crankshafts, namely, super clean steel, technology for improving the fatigue strength of forged steel crank-throws and improved techniques of non-destructive inspection. Also introduced is the development status of highly strengthened intermediate shafts and high-strength steel for rudders.

Introduction

Kobe Steel produces steel castings and forgings, such as cast steel products for rudders, as well as forged steel products including intermediate shafts, propeller shafts and rudder stocks, with the main focus on crankshafts (Fig. 1).

Nowadays, the environmental regulations for vessels are being strengthened step by step, as seen in the regulations on NO_x/SO_x and the introduction of the energy efficiency design index (EEDI),¹⁾ promoting new ship designs as typified by eco-ships, hardware development, including new energy-saving engines, and low-speed cruising.²⁾

With such trends in the vessel industry, we have been improving the quality of vessel components to contribute to the energy saving and reliability improvement of ships. This paper introduces the recent technological development on vessel components produced by Kobe Steel.

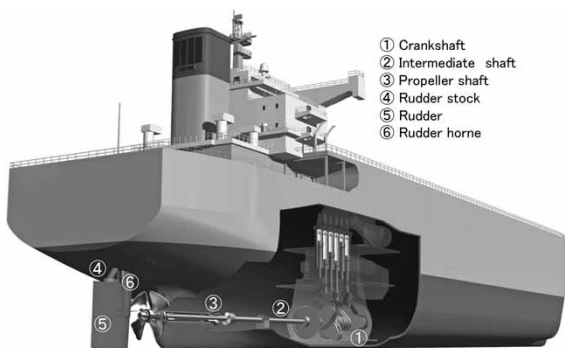

Fig. 1 Marine parts using casting and forging

1. Crankshafts

Diesel-engine crankshafts are positioned as one of the most important components and fall into the two categories of built-up type crankshafts for two-



Fig. 2 Built-up type crankshaft

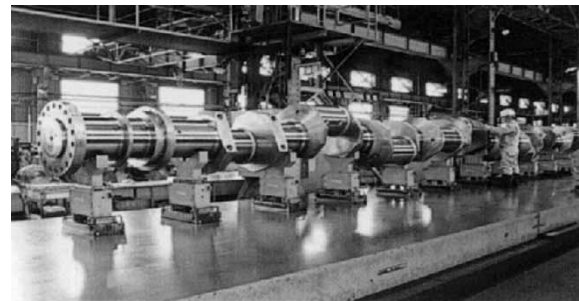

Fig. 3 Solid type crankshaft

stroke engines (Fig. 2) and solid type crankshafts for four-stroke engines (Fig. 3).

1.1 Solid type crankshafts

Four-stroke engines employing solid type crankshafts are used for auxiliary machinery of onboard power generators, as well as for onshore power generators, and require crankshafts with high fatigue strength. The design fatigue strength of crankshafts used for marine diesel engines is stipulated by Equation (1) according to the unified rules (UR) of the International Association of Classification Societies (IACS):³⁾

$$\sigma_{DW} = k \cdot (0.42\sigma_B + 39.3) \cdot \left(0.264 + 1.073D^{-0.2} + \frac{785 - \sigma_B}{4900} + \frac{196}{\sigma_B} \sqrt{\frac{1}{R}} \right) \cdots (1)$$

k : process-dependent coefficient;

σ_B : tensile strength;

D : shaft diameter; and R : fillet radius.

The process-dependent coefficient (k) is given as 1.05 in the case of continuous grain flow (CGF) forging. The CGF forging includes RR forging and TR forging. Fig. 4 shows the RR forging adopted by Kobe Steel.

The fatigue strength of materials is known to be affected significantly by the size of internal defects,

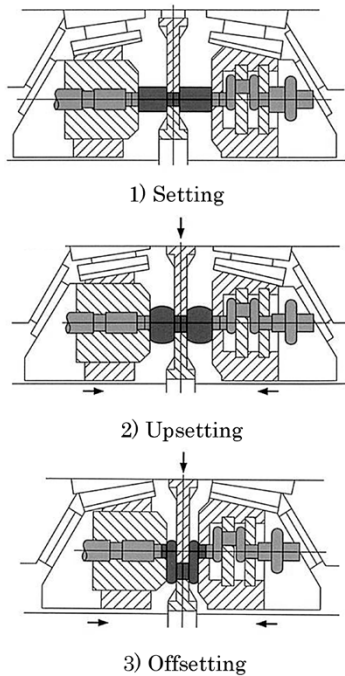

Fig. 4 RR forging

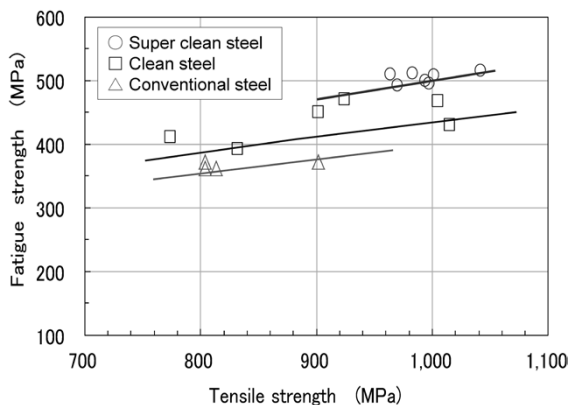

Fig. 5 Fatigue strength of super clean steel for solid type crankshaft

such as non-metallic inclusions, and to decrease with increasing defect size.⁴⁾ With the aim of reducing non-metallic inclusions that can become the origin of fatigue fracture, we have reduced impurities (S, O), optimized the refining conditions, and improved the ingot-making conditions, thus developing a super-clean technology.^{5), 6)} Fig. 5 compares the fatigue strength of super-clean steel with that of conventional steel (tap degassing (TD) processed) and the currently-used steel (clean steel.) The super-clean steel exhibits a fatigue strength 20% or more higher than that of the currently-used clean steel and nearly 40% higher than that of the conventional TD processed steel. On the basis of these results, we applied to the classification societies for approval to use the value of $k=1.15$ for the k -factor in Equation (1) and have received approval for $k=1.15$ from

all the classification societies. Consequently, it is expected that the use of crankshafts produced by the super-clean steel process would make possible an increase in the design fatigue strength and enable the manufacture of smaller engines with higher output. In addition, very-high-cycle fatigue characteristics of crankshafts are being evaluated from the aspect of long-term reliability, and the results that are being obtained indicate that the 40CrMo8 steel (tensile strength: 1,000MPa class) developed by Kobe Steel does not exhibit very-high-cycle fatigue fracture.⁷⁾

In addition, with the aim of achieving even higher fatigue strength, we are developing a high-strength steel with tensile strength of 1,050MPa or higher and technology for imparting compressive residual stress by cold rolling.

1.2 Built-up type crankshaft

Built-up type crankshafts are used for two-stroke diesel engines, the major machinery for rotating propellers; and each comprises a shaft portion, called a "journal," and an eccentric portion, called a "throw": these portions are assembled together by shrink fitting as shown in Fig. 6. For the sake of productivity, Kobe Steel has mainly used cast steel for throws and has worked on the improvement of material properties and reduction of internal defect, which is intrinsic to castings.^{8), 9)} However, the company fully adopted forged steel throws in 2009 in response to anticipated future requirements for more stringent quality control and higher strength. Since then, technological development has been carried out to improve the productivity and quality of forged steel throws.

Fig. 7 shows two methods of forging steel throws. A bending method, in which a plate material is folded by pressing, is commonly used to produce them; however, this forging method requires high-level skills, in ensuring symmetry, for example. Against this backdrop, Kobe Steel developed a die forging method. In die forging, a round slice of bar material is inserted into a die. As a result, the stock material is confined in the die to form crank webs in backward extrusion. This newly developed forging method is independent of skill and stably produces near-net shapes with high symmetry, while significantly improving the productivity. Fig. 8 shows the cross-sectional macrostructure of a throw produced by this die forging (hereinafter referred to as a "die-forged throw.") The symmetry is excellent and no grain flow is observed in the fillet. A dark portion of a grain flow corresponds to microsegregation, in which an alloying element is concentrated, and is prone to form inclusions.

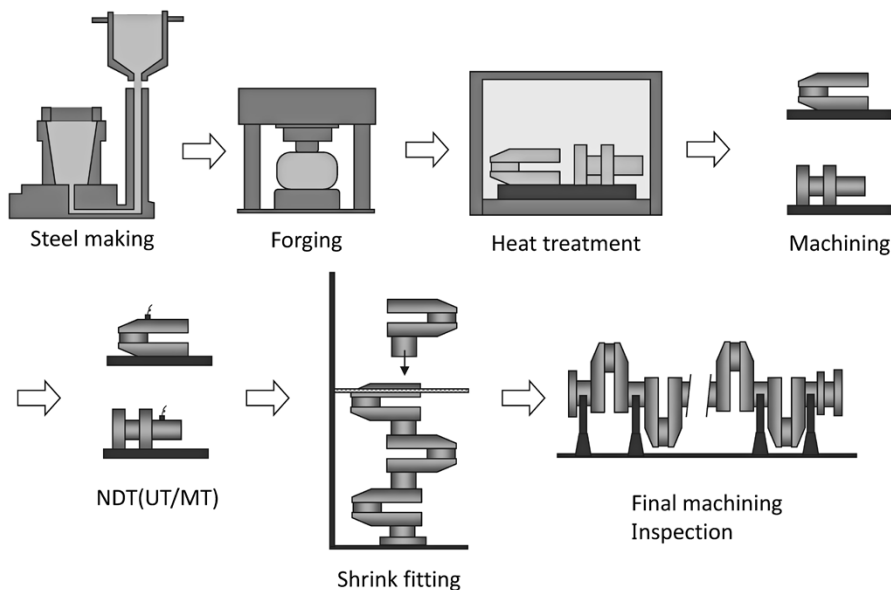

Fig. 6 Manufacturing of built-up type crankshaft

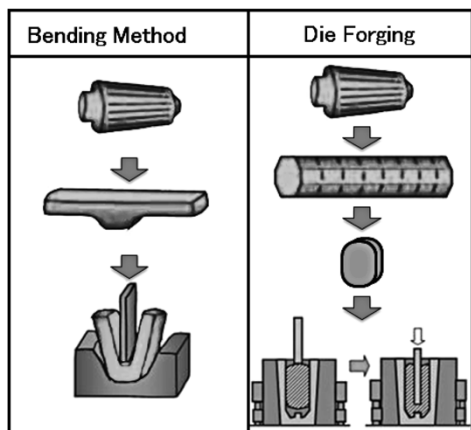

Fig. 7 Forging method of crank-throw

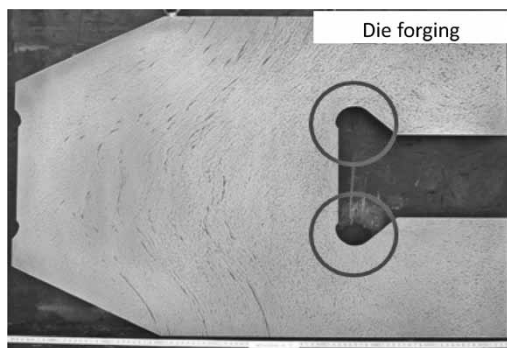

Fig. 8 Cross section of throw made by die forging

Because of the forging method, the fillet of a die-forged throw has no grain flow crossing there and is formed of a highly-clean portion without an inclusion due to microsegregation. It can be said that an effect is exerted that is similar to that of the CGF forging in solid type crankshafts. Fig. 9 shows the result of a fatigue test on a die-forged throw, in

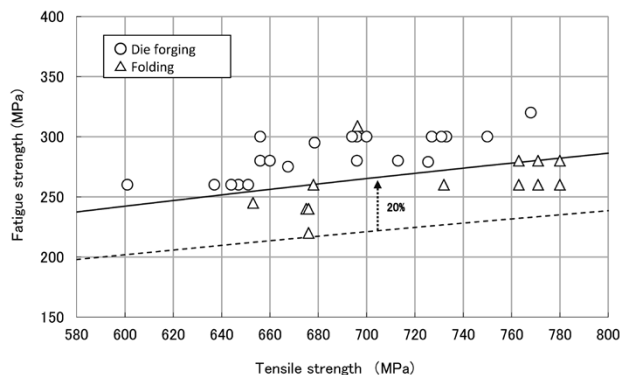

Fig. 9 Fatigue strength of forged throw

which sulfur (S) has been reduced to improve the cleanliness. Also shown in the figure is the result of a test on a fold-forged throw. Including the effect of reduced sulfur, the die-forged throw shows an approximately 20% improvement over the fold-forged throw. On the basis of this result, we have obtained special approval for a k-factor of $k=1.05$ in the equation of the fatigue strength calculation (Equation (1)) from Class NK (Nippon Kaiji Kyokai), the ship classification society of Japan.

In the case of the grades of steel used for built-up type crankshafts, a smaller crankshaft having a cylinder diameter of approximately 400mm or less uses low alloy steel with a tensile strength of 800MPa, while a medium or larger sized crankshaft having a cylinder diameter of approximately 500mm or greater mainly uses carbon steel. This is due to the fact that, in the case of built-up type crankshafts produced by shrink fitting, low alloy steel has a higher risk of quenching cracks as the throw becomes larger in size. Therefore, we are working to develop a low alloy steel that can achieve higher

productivity.

1.3 Non-destructive testing technology for crankshafts

In order to secure the reliability of a crankshaft, its internal quality must be stringently controlled, and this is particularly so for its fillet, to which high stress is applied. This requires a well-established inspection technology. The conventional method has been ultrasonic inspection using manual scanning probes. Meanwhile, we have developed^{10), 11)} and adopted automatic ultrasonic inspection systems for built-up type crankshafts and solid type crankshafts.

Fig.10 shows the scanning system for an automatic ultrasonic inspection system for the throws of built-up type crankshafts. This system comprises a pin scanning unit (Fig.10 (A)) and a fillet scanning unit (Fig.10 (B)), wherein these two units are coupled by a roller chain so that they can be fixed at positions opposing one another at 180 degrees with a pin in the middle. In this configuration, the units can automatically run (rotate) around the pin to detect flaws. The pin scanning unit includes an oblique angle probe for detecting near-surface layers and a vertical probe for detecting deep portions, wherein the unit reciprocally scans in the axial direction of the pin. The fillet scanning unit includes an oblique angle probe having a convex curved surface that fits along the rounded portion of a fillet and an oblique angle probe for detecting flaws in the linear slope, wherein the unit scans the area predetermined for each fillet type in a playback manner. The flaw detection units for both pins and fillets move at a constant pitch along the circumferential direction at the end of one scan and complete the flaw detection of the entire area of a pin and fillet by making one round. In terms of defect detectability, the system can detect a flat bottom hole (FBH) with a diameter of 1.0mm.

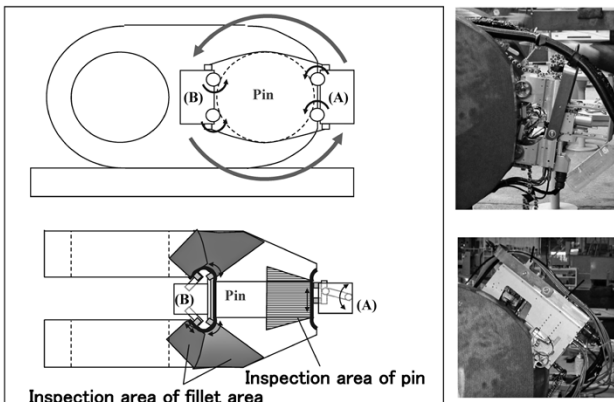

Fig.10 Scanning system for automatic ultrasonic inspection of throw

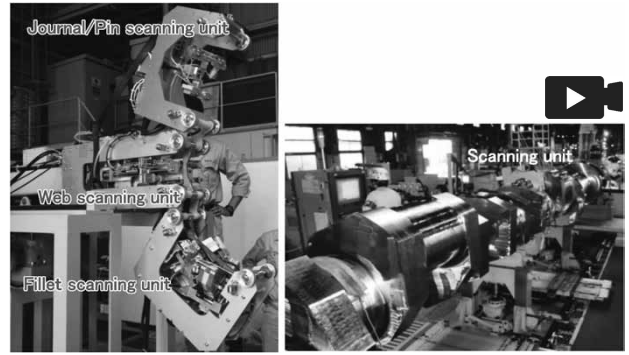

Fig.11 Scanning mechanism of automatic ultrasonic inspection for solid type crankshaft

For solid type crankshafts, we have developed an automatic ultrasonic inspection system with a resolution that can detect an FBH with a diameter of 0.5mm.¹¹⁾ **Fig.11** shows the scanning mechanism of the newly developed system and the system in operation. A scanning head includes a unit for scanning the parallel portions of pins/journals, a unit for scanning fillets and a unit for scanning throw arms, and carries out the inspection while tracking and rotating around the crankshaft. The fillet scanning unit of this system includes a plurality of ultrasonic transducers arranged in an array and adapts a phased array method, which can generate various ultra sonic pulses.

These automatic ultrasonic inspection systems are connected to a computer system, in which data are stored as digital data to ensure the traceability, including the confirmation of defects in a relevant crankshaft.

2. Intermediate shafts

Intermediate shafts transmit engine output to propellers. Since they are subjected to vibrations from engines and vibrations associated with propeller motion, they are required to have excellent torsional fatigue strength. The diameter of an intermediate shaft is calculated in accordance with Equation (2) defined by classification rules, and the maximum tensile strength usable is stipulated not to exceed 800MPa.¹²⁾

$$d = F \cdot k \cdot \sqrt[3]{\frac{P}{n_0} \cdot \frac{1}{1 - \frac{d_1^4}{d_0^4}} \cdot \frac{560}{\sigma_B + 160}} \dots\dots\dots (2)$$

where F: constant depending on the types of shaft components;

k: shape factor;

n_0 : revolution per minute; p , rated power;

d_1 : diameter of the shaft center bore; and

d_0 : shaft component diameter.

Although the reasons for setting the upper

limit of tensile strength at 800MPa is not clear, it is assumed to be attributable to the fact that the torsional fatigue strength in the region beyond 800MPa had not been clarified. Against this backdrop, we evaluated the torsional fatigue characteristics of 40CrMo8 steel, which was developed by the company and has achieved results in solid type crankshafts. As shown in Fig.12, it has been confirmed that the torsional fatigue strength exhibits no reduction and increases proportionally with the increase of tensile strength. Also confirmed was that the notch sensitivity and the safety factor stipulated by classification rules against vibration stress are equivalent to those for conventional steel.¹³⁾

On the basis of these results, the Class NK (Nippon Kaiji Kyokai) approved the use of the 40CrMo8 up to 950MPa grade for the strength calculation. In addition, via the Class NK (Nippon Kaiji Kyokai), the IACS added APPENDIX I to UR M68 in April 2015 to provide special approval for using the alloy steel having a strength between 800MPa and 950MPa as the material for intermediate shafts.

An intermediate shaft with increased strength is expected to increase the engine output and to reduce the number of or eliminate vibration suppression devices, because the material strength is increased without changing the shaft diameter as shown in Fig.13 (A), and the allowable vibration stresses (τ_1 , τ_2) are raised. Also, a shaft diameter reduced by increased strength results in a lower natural frequency for a given engine output, which is considered to shift the barred range towards the low rotation side (Fig.13 (B).) In the figure, the speed ratio, λ , of the horizontal axis represents the ratio to the rated maximum revolution (revolution/rated revolution.) As a result, it is considered that the normal revolution can be reduced while providing an extra margin for low-speed cruising.

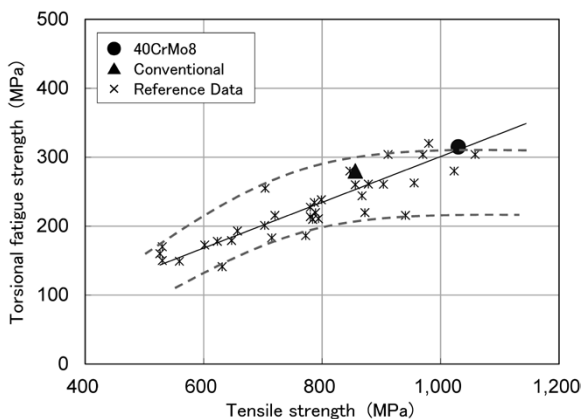
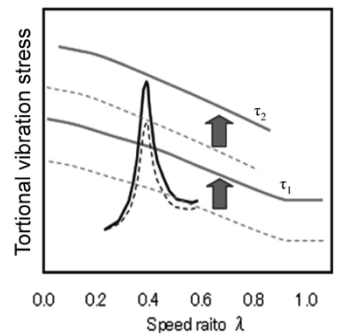
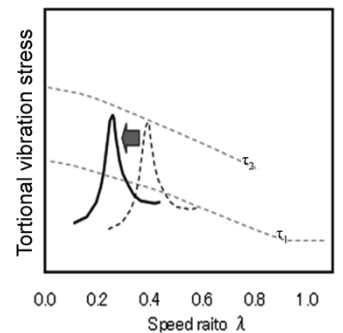

Fig.12 Relationship between tensile strength and torsional fatigue strength



(A) In the case of diameter immutability



(B) In the case of decreased diameter

Fig.13 Effect of applying high-strength intermediate shaft

3. Rudder components

A rudder is a device for controlling the course of a vessel. Various types and structures of rudders have been devised for the abilities of slewing and thrusting. Fig.14 shows a mariner rudder as a typical example. Here, the rudder stock and pintle, which constitute the slewing shaft (rudder shaft), are made of steel forgings, whereas the bearing portions of a rudder and rudder horn are made of steel castings. In some cases, the rudder horn is made of solid type steel castings.

Reducing the rudder thickness (t) decreases velocity resistance of a vessel and thus is considered to improve the fuel mileage. In order to reduce the rudder thickness (t), it is considered to be effective, from the Fig.14 bottom (cross-sectional view), to reduce the diameters of the pintle and rudder horn, that is, to increase the strength of the steel castings and forgings for rudders. It should be noted that the classification rules require rudder stocks and pintles to have weldability and stipulate that their carbon content be 0.23% or less.¹⁴⁾ A low-alloy steel (steel name: KSFA65W-S), as shown in Table 1, has been developed as a high-strength material that satisfies the above requirement and has the high yielding point required for designing; the alloy obtained special approval from major classification societies. This steel has been used for many rudder stocks and pintles actually used on-board.

As for steel castings, the classification rules

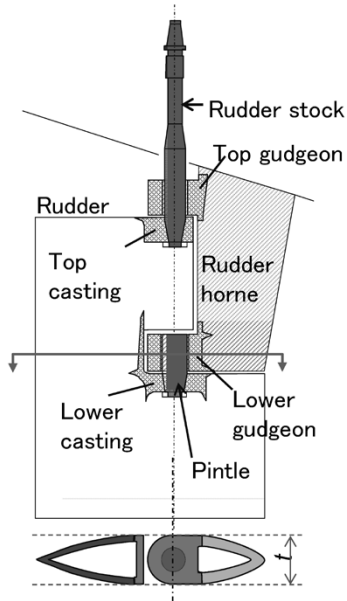

Fig.14 Schematics of cross section of mariner rudder

Table 1 Mechanical properties of low alloy steel KSAF65W-S for rudder-stock and pintle

Tensile strength (MPa)	Yield strength (MPa)	Elongation (%)		Reduction of area (%)	
		Longitudinal	Tangential	Longitudinal	Tangential
640-790	445 min.	17 min.	12 min.	50 min.	35 min.

Table 2 Mechanical properties of low alloy cast steel for rudder parts

Grade	Tensile strength (MPa)	Yield Strength (MPa)	Elongation (%)	Absorption energy at 0°C (J)
SCAH450W	450 min.	255 min.	20 min.	27
SCAH480W	480 min.	275 min.	20 min.	27
SCAH550W	550 min.	355 min.	18 min.	27
SCAH620W	620 min.	430 min.	17 min.	27

restrict their composition range.¹⁴⁾ Four grades of materials, as shown in **Table 2**, which are based on SCW620 steel casting for welded structure according to JIS, have obtained material approvals. The steel castings have a structure in which the castings are welded with thick steel plates. Optimization is being carried out to eliminate preheating of welding in order to facilitate plate working and with consideration to workability in attaching solid type

rudder horns to the stems of vessels. This project is almost completed.

Conclusions

This paper introduces the development status of Kobe Steel's technologies for steel castings and forgings for vessels.

We will continue to develop technological seeds that contribute to increasing the value of vessels (improvements in fuel consumption, quality and reliability) on the basis of the material technology, component-forming technology and inspection technology introduced in this paper, and strive to contribute to the development of shipping and shipbuilding industries by responding to customers' needs.

References

- 1) S. Ishida. *Journal of the Japan Institution of Marine Engineering*. 2011, Vol. 46, No. 6, pp. 46-48.
- 2) M. Kondo et al. *Journal of the Japan Institution of Marine Engineering*. 2011, Vol. 46, No. 2, pp. 5-9.
- 3) *Calculation of Crankshaft for I.C. Engines*. Unified Requirement M53s of International Associations of Classification Societies Ltd.
- 4) Y. Murakami, *Metal fatigue: Effects of Small Defects and Nonmetallic Inclusions*. Yokendo, 1993, p. 265.
- 5) Fujitsuna et al. *17th International Forgemasters Meeting*. 2008, p. 390.
- 6) T. Shinozaki et al. *R&D Kobe Steel Engineering Reports*. 2009, Vol. 59, No. 1, pp. 94-97.
- 7) R. Yakura et al. *27th CIMAC Congress*. 2013, Paper No. 442.
- 8) Y. Yoshida et al. *R&D Kobe Steel Engineering Reports*. 2005, Vol. 55, No. 3, p. 7.
- 9) Y. Yoshida et al. *R&D Kobe Steel Engineering Reports*. 2005, Vol. 55, No. 3, p. 13.
- 10) A. Okamoto et al. *R&D Kobe Steel Engineering Reports*. 2005, Vol. 55, No. 3, p. 16.
- 11) Hamano et al. *19th International Forgemasters Meeting*. 2014, p. 520.
- 12) *Dimensions of propulsion shafts and their permissible torsional vibration stresses*. Unified Requirements M68 of International Associations of Classification Societies Ltd.
- 13) T. Ikegami et al. *10th International Symposium on Marine Engineering (ISME2014)*.
- 14) Class NK (Nippon Kaiji Kyokai). *Rules for the Survey and Construction of Steel Ships Part K MATERIALS*.