

New Arc-welding Robots

Tatsuji MINATO*1, Taichi IGARASHI*1, Motoaki MURAKAMI*2, Takashi WADA*3

*1 Welding System Dept., Technical Center, Welding Business

*2 Technical Center, Welding Business

*3 Production Systems Research Laboratory, Technical Development Group

A series of arc-welding robots, the ARCMAN™ series, comes in sizes suitable for various welding objects, and many have been adopted by users in the field of medium and heavy plate. This paper introduces the features of a large-sized robot, ARCMAN™ A80, and a small-sized robot, ARCMAN™ A30, both newly developed. ARCMAN™ A80 is a robot suitable for welding large structures, such as construction machinery, and has enhanced features for improving welding applicability, including an expanded approach area around work pieces, while inheriting the features of the conventional ARCMAN™ XL. ARCMAN™ A30 is a small robot aimed at applications in narrow spaces and features an operating speed and arm shape particularly suitable for the assembly process of shipbuilding.

Introduction

Kobe Steel's arc-welding robots have been widely used around the world in the fields of medium and heavy plate (e.g., construction machinery, steel frames, bridges and railway vehicles).

Fig. 1 shows an example of the welding system. In the field of medium and heavy plate, where work pieces (welding objects) tend to have large sizes, it is difficult for a single robot to cover all the welding locations of a work piece within its work envelope. Each Kobe Steel welding system combines a robot that is suitably sized for work pieces, a transfer apparatus upon which the robot is mounted, and a positioner which places each work piece in its optimum welding postures: the equipment is configured to cover the welding locations required. Kobe Steel has an assortment of small to large-sized robots, all of which have the dynamic characteristics necessary for realizing high quality welding.

Fig. 2 shows the lineup of the Kobe Steel robots. Each small-sized robot has a small mass and imposes a minimal burden on its transfer apparatus, making the system lighter and more compact. On the other hand, the maximum reach of each small-sized robot is limited, giving it a small work envelope, which is disadvantageous in application to larger work pieces. The opposite is true for large-sized robots. This is the reason why many welding systems adopt medium-sized robots, each having a maximum reach of 1,300 to 1,800 mm with an excellent balance between the work envelope area and robot mass.

Meanwhile, a large-sized robot that has been

given the maximum reach can simplify the system configuration, since the robots can be applied to the welding locations of each work piece without being mounted on a transfer apparatus. In this respect, the large robots are highly valuable. In the case of shipbuilding, etc., which requires entrance into space-limited members, such as the inside of a work piece, a small-sized robot makes it possible to automate the jobs that have hitherto been done by welders.

This paper introduces the features of a large-sized arc-welding robot, ARCMAN™ note 1) A80, which has been modified from its conventional model, and a newly developed small-sized arc-welding robot, ARCMAN™ A30.

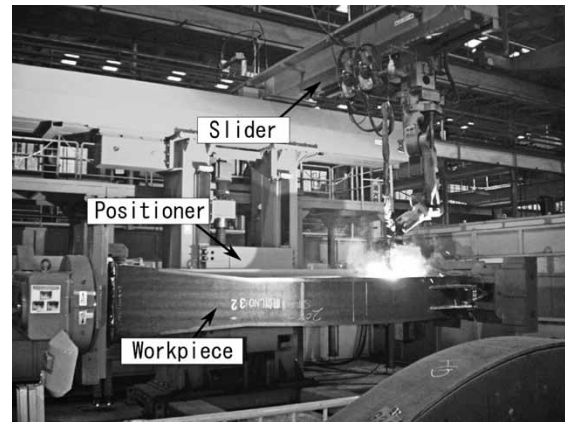

Fig. 1 Welding system

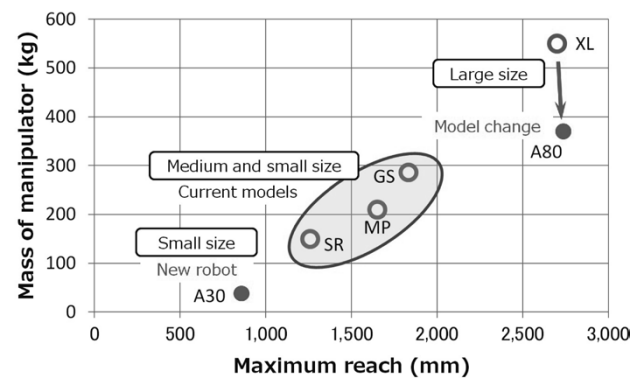

Fig. 2 Lineup by robot size

note 1) ARCMAN™ (ARCMAN™) is a trademark of Kobe Steel.

1. Large-sized arc-welding robot, ARCMAN™ A80

In the past, the largest sized model among the line-up of Kobe Steel's robots was ARCMAN™ XL (Fig. 2, Fig. 3). Its maximum reach is 2,698 mm at point P (the center of the S5 rotation axis), and this feature has been advantageously exploited in applications in industries such as construction machinery and railway vehicles, where large work pieces are handled. ARCMAN™ A80 has been developed as a successor of ARCMAN™ XL and has additional features that make it more suitable for large work pieces.

1.1 Advantages of ARCMAN™ A80

The following describes the main advantages of ARCMAN™ A80:

- Adoption of serial link: Expansion of the area of approach to work pieces

The enlargement of the work envelope and the postures in which the upper robot arm bends to the rear of the robot (reverse posture) have enabled approaching work pieces that have previously been impossible to reach (Fig. 4).

- Cables built into S1 axis: Prevention of interference between cables and work pieces

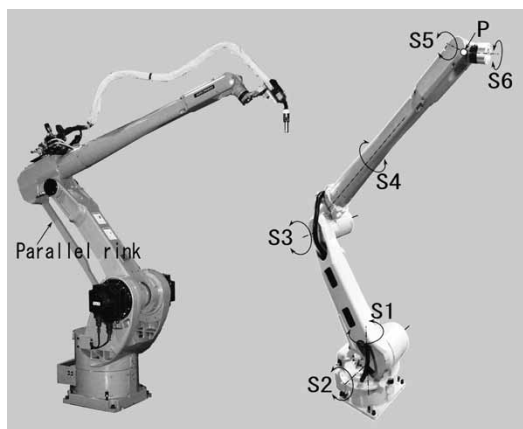

Fig. 3 ARCMAN™ XL (left) & ARCMAN™ A80 (right)

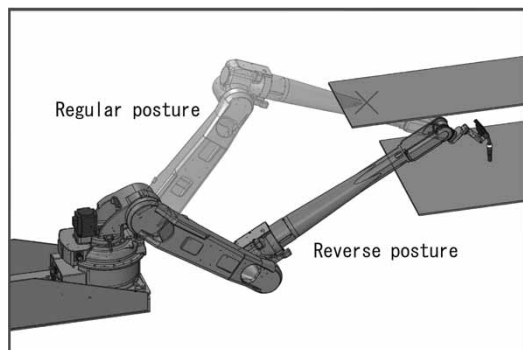

Fig. 4 Reverse posture of ARCMAN™ A80

ARCMAN™ A80 inherits the long arm, the greatest advantage, of ARCMAN™ XL, and has the same arm length as the latter so as to be compatible with already-delivered systems, their replacement being taken into account. In addition, the frame has been optimized by using the latest parts and design/analysis with 3D-CAD. Furthermore, serial linking has been adopted, as described later. These measures have realized a reduction in weight that makes the apparatus approximately 35% lighter than conventional models. In terms of performance, the operational speed has been increased to improve productivity.

1.2 Adoption of serial link

ARCMAN™ XL adopts a parallel link structure, which has enabled a reduction in the capacity of the driving motor of the S3 axis and also has been advantageous in terms of rigidity. There have, however, been drawbacks such as a limited work envelope, limited operational speed, increased robot size and increased number of parts. By adopting a serial link, ARCMAN™ A80 has managed to improve its performance while reducing the number of parts and the weight.

Structurally, it is much more difficult to secure rigidity in a serial-link type robot than in a parallel-link type robot, and the reduction in rigidity leads to the deterioration of weaving accuracy, which is important in the welding of medium-to-heavy gauge plates. In particular, a large-sized robot has a long span from its robot base to its torch; hence, the deterioration in accuracy can be significant, causing serious problems. This problem has therefore been solved from the aspects of both design and control.

In the mechanical design, a high rigidity has been achieved by optimizing the frame shape using 3D-CAD and numerical analysis. Fig. 5 shows a robot posture and its FEM model, whose posture

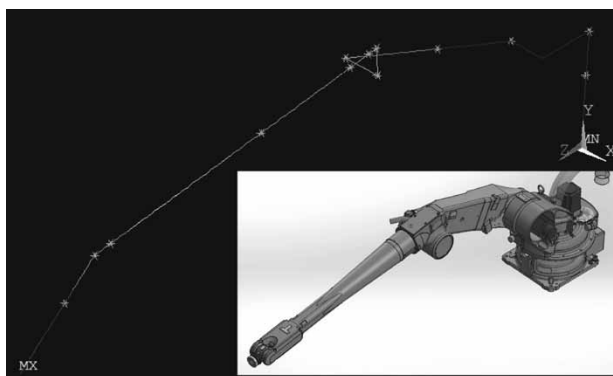

Fig. 5 FEM model of ARCMAN™ A80

during welding requires the greatest strictness in regard to locus accuracy. By expressing the robot postures according to the FEM analysis model, the natural frequency of the robot as a whole has been predicted. In addition, the important reinforcement points that contribute largely to overall rigidity have been identified to attempt an improvement in the rigidity. As a result, a rigidity almost equal to the theoretical value, in which the frame is deemed a rigid body, has been secured successfully.

In terms of control, a numerical model closer to the actual machine has been created to improve the rigidity and the accuracy of locus simulation in prototype design. This model has been used to perform a highly accurate simulation of the resonance phenomena occurring at the tool center position (TCP), especially during weaving. As shown in Fig. 6, the simulator consists of a robot model and a controller model. For the robot model, Simscape Multibody™ (simulation tool made by MathWorks®) has been used to incorporate the design data of the 3D-CAD to create precise models for the link structure of the robot, as well as the mass, the position of the center of gravity, and the inertia of each link. For the controller model, the actual controller source code has been used to

reproduce the control algorithm with Simulink™ (made by MathWorks®). An example of TCP locus during weaving is shown in Fig. 7. It has been confirmed that the simulation well reproduces the robot tip behavior of the experimental machine. It should be noted that, for the purpose of achieving the desired weaving accuracy, the robot control algorithm^{1),2)} comprises not only feedback control, but also a two-degree-of-freedom control according to feedforward control based on a dynamic model, an elastic deformation compensation control for correcting robot deflections by inertial force and/or gravity, and a periodic disturbance observer focusing on periodic disturbance components. Fig. 8

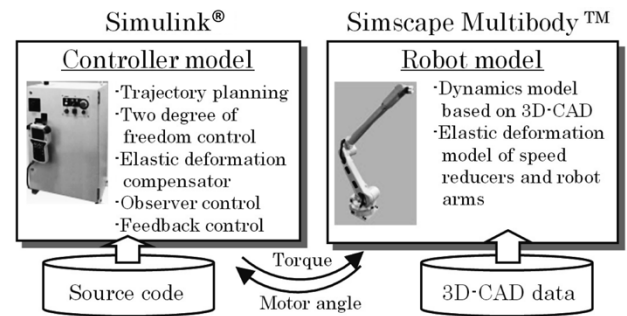

Fig. 6 Simulation collaborating with 3D-CAD

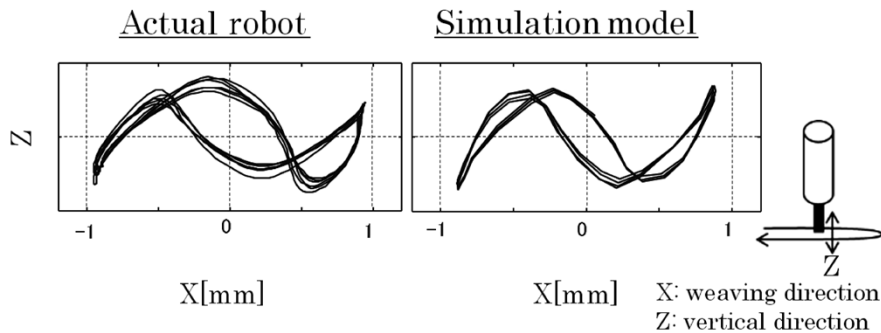

Fig. 7 TCP behavior during weaving action of actual robot and simulation

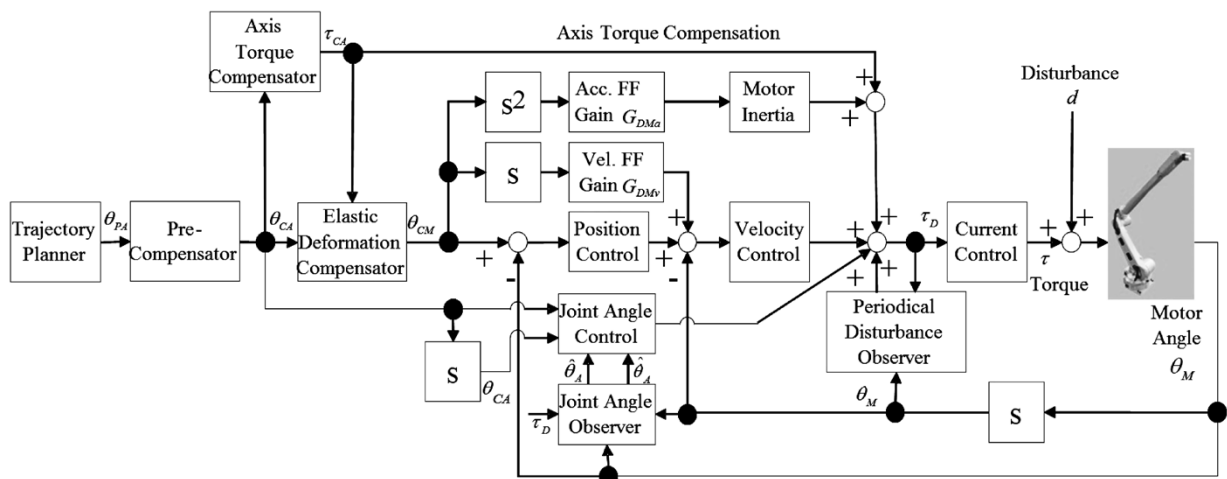

Fig. 8 Block diagram of control system

shows the control block diagram of the robot.

The simulator thus constructed has been exploited to tune the control parameters and brush up the control algorithm, which has solved the problem of the operational accuracy being deteriorated due to robot resonance.

The increased rigidity of the robot along with the new control technology has secured the desired weaving accuracy of the actual ARCMAN™ A80 machine adopting the serial link.

1.3 Built-in cables

In the field of medium and heavy plate, in particular, welding is performed with a current typically exceeding 400A and, hence, requires large-diameter welding cables and torch-cooling water hoses, all of which must withstand the high current. In addition, there are cases where tools are changed, or optional sensors are used together, which tends to increase the number of cables. When these cables follow the motion of the robot and are shaken, they may interfere with the work piece and peripheral devices constituting the welding system. In addition, instruments for holding the massive cables are also required, and addressing these problems can limit the layout design of the system.

For that reason, ARCMAN™ A80 comprises, in particular, a welding power cable with a large diameter and greater mass, and the cable is fitted along the machine frame of the arm part and built into the robot in the base part. Through these measures, the layout design of the welding system has been made more flexible, so as to improve the applicability and welding quality of the system.

2. Advantages of small-sized arc-welding robot, ARCMAN™ A30

The appearance of ARCMAN™ A30 is shown in Fig. 9. This machine comprises a small-sized robot aiming at applications such as the assembly processes of shipbuilding, where welding work must be performed inside the space-limited parts of work pieces.

2.1 Two types of specifications adapted for applications

Japanese Ordinance on Industrial Safety and Health stipulates that "The employer shall, in the case where an industrial robot is operated, and when it is liable to endanger workers due to contact with the said industrial robot, take the necessary measures of providing a railing, an enclosure, etc.,

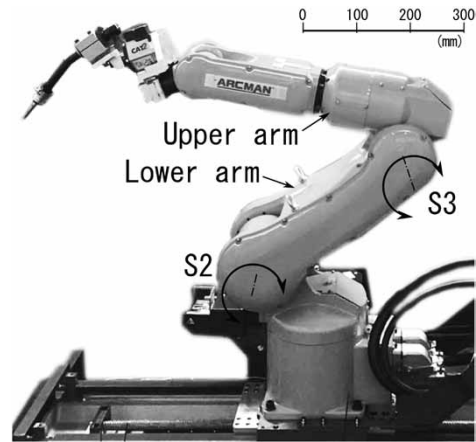

Fig. 9 ARCMAN™ A30

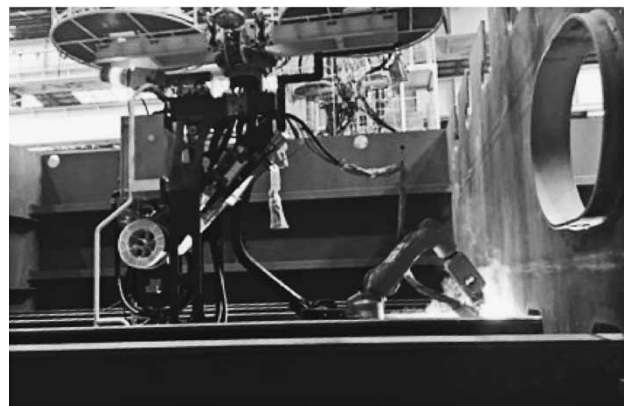

Fig.10 Welding site at shipbuilding yard

to prevent the said dangers (Article 150-4)," for industrial robots, each having a rated power greater than 80W.

Fig.10 shows welding work performed in the shipbuilding assembly process, which is the major target of ARCMAN™ A30. On such a work site, isolating workers and robots with a railing or enclosure (hereinafter referred to as "safety fences") is difficult due to operational constraints, and it is necessary to take measures for the above rules to secure safety. On the other hand, industries and work sites that can install safety fences require increased speed (increased output) of the robot in order to improve their productivity.

To cope with these contradictory problems and needs, two types of servo amplifiers have been provided to limit the motor output on the controller side, enabling the robots to be deployed in a wider range of fields and markets.

2.2 Lower-arm structures for realizing small size

In shipbuilding, the assembly processes require robots to enter narrow spaces inside the hull blocks and to take welding postures for horizontal fillet

welding and vertical position welding. Hence, the robot arms, both lower and upper, must have relatively short link lengths. Therefore, in some welding postures, there is a concern that the torch cable may wrap around a protrusion on the robot, rendering welding impossible. Against this backdrop, ARCMAN™ A30 has been given a structure in which the motors of the S2 axis and the S3 axis are built into the lower arm so as to eliminate protrusions on the robot surface as much as possible. In order to arrange the two motors of the S2 axis and the S3 axis in the limited space inside the lower arm, a belt tension adjuster has been shared by the S2 axis and the S3 axis (**Fig.11**). The resin casing that covers

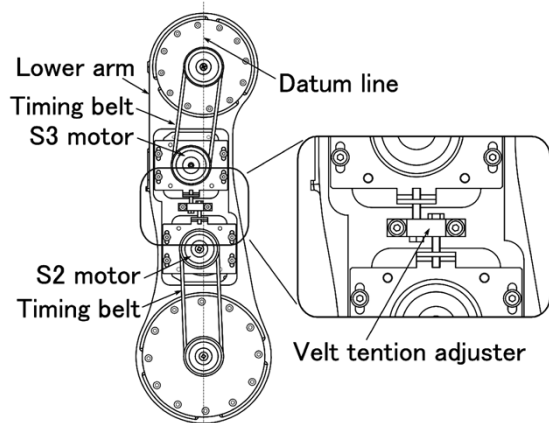

Fig.11 Structure of lower arm

the belts and pulleys also has a rounded design. Thanks to this devising, welding has been made possible without the fear of the cable being caught by the robot body even when welding in narrow spaces.

Conclusions

The lineup of Kobe Steel's arc-welding robots has been explained along with the advantages of the new models. We will strive to provide welding systems best suited to each type of welding job, offering ARCMAN™ A80 for the welding of large-sized structures such as construction machinery, and ARCMAN™ A30 for space-limited members such as those found in the assembly process of shipbuilding.

References

- 1) Y. Nishida et al., Journal of the Society of Instrument and Control Engineers. 2012, Vol.51, No.9, pp.874-879.
- 2) S. Inada et.al. R&D Kobe Steel Engineering Reports. 2013, Vol.63, No.1, pp.89-93.